

Source Test Procedure **ST-27**

**GASOLINE DISPENSING FACILITY
DYNAMIC BACK PRESSURE**

(Adopted January 20, 1982)

REF: Regulation 8-7-302

1. APPLICABILITY

- 1.1** This procedure is used to verify compliance with the applicable dynamic back pressure limits imposed on any Phase II vapor recovery system. The applicability of the following Alternate Methods is dependent upon the regulatory requirements imposed by the California Air Resources Board (CARB) Executive Order.
- 1.1.1 Alternate Method 1.** This procedure is applicable if the dynamic back pressure standards are imposed from the nozzle to the gasoline storage tank, provided remote vapor check valves are not part of the Phase II system.
- 1.1.2 Alternate Method 2 & 3.** These procedures are applicable if the dynamic back pressure standards are imposed from the nozzle to the gasoline storage tank and a remote vapor check is installed as part of the Phase II system.
- 1.1.3 Alternate Method 4.** This procedure is applicable if the dynamic back pressure standards are imposed from the Phase II riser to the gasoline storage tank, provided there is no vacuum-producing device located between the riser and tank.
- 1.1.4 Alternate Method 5.** This procedure is applicable if the dynamic back pressure standards are imposed at the nozzle/vehicle interface during vehicle fueling.
- 1.1.5 Alternate Method 6.** This procedure shall be conducted, in conjunction with the applicable of Alternate Methods 1, 2, 3 or 4, if the Phase II system utilizes an incinerator.
- 1.2** Alternate Methods 1, 2, 3, and 4 shall be conducted with the Phase I vapor poppet **open**. Alternate Methods 5 and 6 shall be conducted with the poppet **closed**.
- 1.3** Other Alternate Methods may be used provided that written approval has been granted by the Manager of the Source Test Section. Such approval shall be based upon demonstrated equivalency of any proposed methodology.

2. PRINCIPLE

- 2.1** Using Alternate Methods 1, 2, 3, 4, or 6, the dynamic back pressure during vehicle fueling is simulated by passing nitrogen through the Phase II recovery system at specified rates. The resultant dynamic back pressure is measured using a pressure gauge, or equivalent device. Alternate Methods 2 and 3 are included for those Phase II systems that utilize both bellows-equipped nozzles and a remote

vapor check valve. Alternate Method 5 is a direct measurement of the pressure at the nozzle/fillpipe interface during gasoline dispensing.

3. RANGE

- 3.1** The minimum and maximum dynamic back pressures that can be measured are dependent upon available pressure gauges. Recommended gauge ranges are as follows:
- 3.1.1 Alternate Methods 1 and 3.** 0-0.5 and 0-2 inches H₂O.
 - 3.1.2 Alternate Method 2.** 0-0.5 and 0-1 inches H₂O.
 - 3.1.3 Alternate Method 4.** 0-0.25 inches H₂O.
 - 3.1.4 Alternate Method 5.** -1-0-+1 inches H₂O.
 - 3.1.5 Alternate Method 6.** 0-0.5 and 0-1 inches H₂O.
- 3.2** If mechanical pressure gauges are employed, the minimum diameter of the gauge face shall be four inches, and the minimum accuracy of the gauge shall be three percent of full scale.
- 3.3** If an electronic pressure measuring device is used, the full-scale range of the device shall not exceed 0-10 inches H₂O with a minimum accuracy of 0.5 percent of full scale. A 0-20 inches H₂O device may be used provided that the equivalent accuracy is not less than 0.25 percent of full-scale.

4. INTERFERENCES

- 4.1** Any leaks in the nozzle vapor path, vapor hose, or underground vapor return piping may result in erroneously low dynamic back pressure measurements.
- 4.2** For those Phase II systems possessing a design incompatible with this test procedure, testing shall be conducted in accordance with the procedures specified in the applicable CARB Executive Order.
- 4.3** Testing of systems that have liquid condensate traps in the underground vapor return piping that contain liquid at the time of the test may result in erroneously high dynamic back pressure measurements.
- 4.4** Measuring dynamic back pressure without waiting a minimum of 30 seconds for the flow of nitrogen to stabilize may result in erroneous back pressure measurements.

5. APPARATUS

- 5.1** Nitrogen High Pressure Cylinder with Pressure Regulator. Use a high pressure nitrogen cylinder capable of maintaining a pressure of at least 2000 psig and equipped with a compatible two-stage pressure regulator and a one psig relief valve. A ground strap is recommended during introduction of nitrogen into the system.
- 5.2** Rotameter. Use a calibrated rotameter capable of accurately measuring nitrogen flowrate(s) applicable for the imposed dynamic back pressure limits.
- 5.3** Pressure Gauges. Use differential pressure gauges, or equivalent, as specified in the applicable subsection of Section 3.1.

- 5.4 Automobile fillpipe. Use a automobile fillpipe, or equivalent, known to be compatible with all bellows-equipped vapor recovery nozzles, and equipped with a pressure tap. See Figure 27-1.
- 5.5 Nitrogen. Use commercial grade nitrogen in a high pressure cylinder, equipped with a two-stage pressure regulator and a one psig pressure relief valve.
- 5.6 Hand Pump. Use a gasoline compatible hand pump, if applicable, to drain any gasoline from condensate pots.
- 5.7 Stopwatch. For Alternate Method 5, use a stopwatch, or equivalent, accurate to within 0.5 seconds.
- 5.8 Gasket. Use a flat gasket made of a gasoline compatible material with dimensions similar to the torus shown in Figure 27-4, to ensure proper seal between the nozzle and the Dynamic Back Pressure Assembly.

Figure 27-1
Dynamic Back Pressure Test Assembly

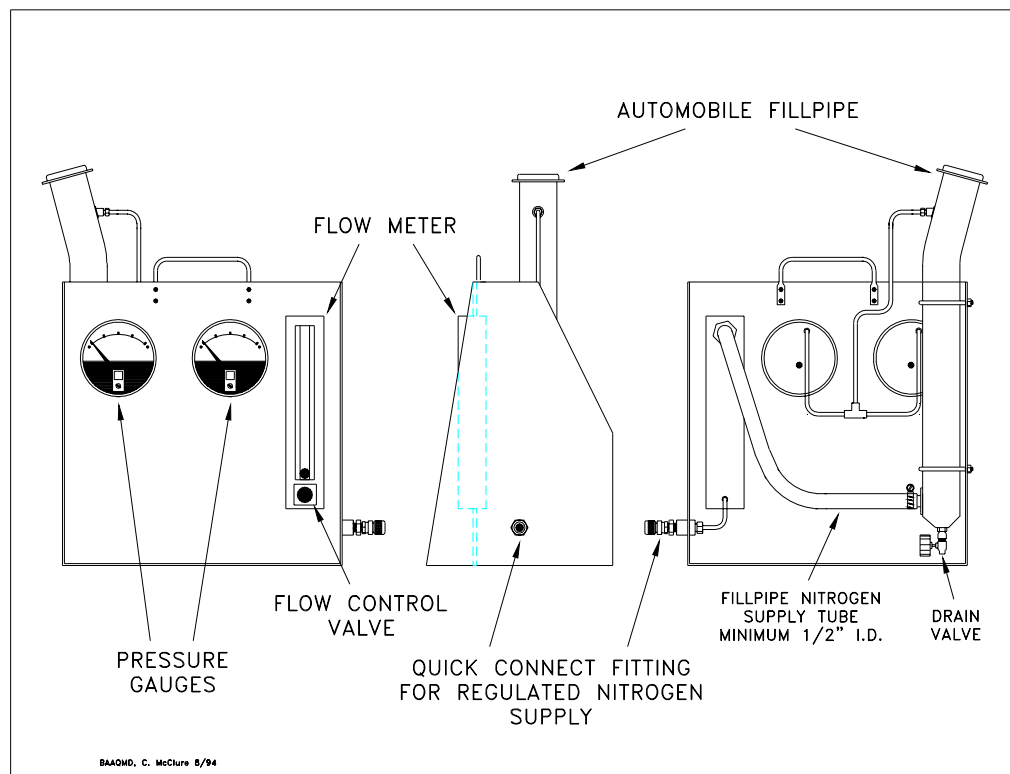

6. PRE-TEST PROCEDURES

- 6.1 Alternate Method 1.** The following subsections are applicable for those Phase II systems where a limitation is imposed on the dynamic back pressure between the nozzle and the gasoline storage tank, provided that remote vapor check valves are not employed. For those Phase II systems which **do not** utilize a remote vapor check valve, assemble the apparatus as shown in Figure 27-1, ensuring that the flow meter control valve on the test equipment is closed. If a central vacuum system is used, the vacuum producing device should be turned off during this test.

- 6.1.1 Assemble the Dynamic Back Pressure Test Assembly as shown in Figure 27-1, ensuring that the rotameter control valve is closed.
- 6.1.2 The test equipment must be leak-checked prior to use. Plug the nozzle end of the auto fillpipe and open the nitrogen cylinder. Adjust the flow meter control valve until a pressure of 50 percent of full scale is indicated on the high range pressure gauge. Close the nitrogen cylinder valve and any toggle valves. A pressure decay of less than 0.2 inches H₂O, in five minutes, is considered acceptable.

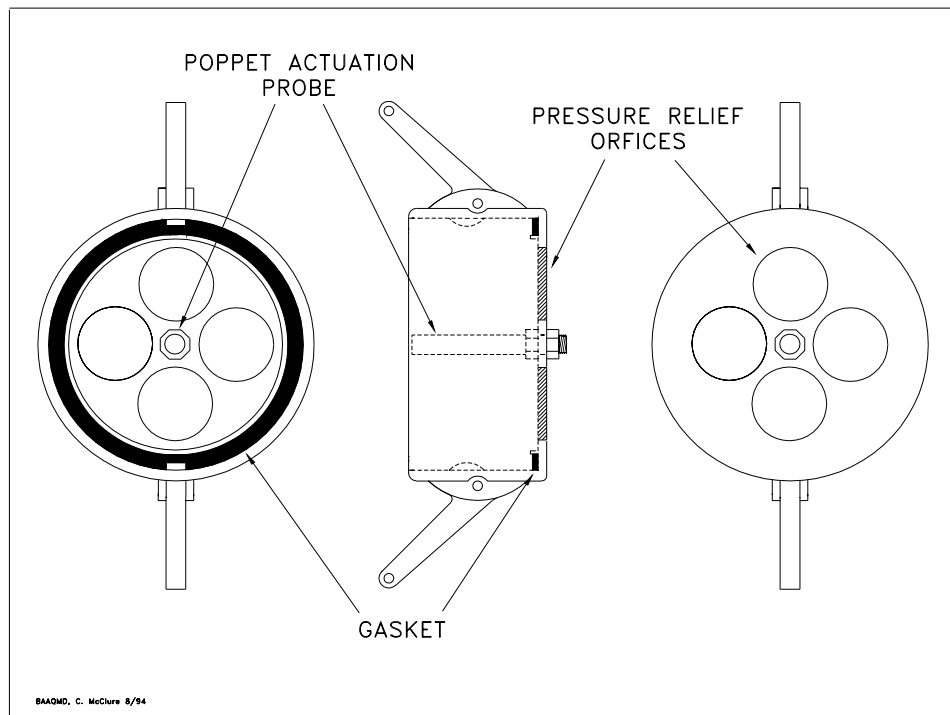
Figure 27-2**Dynamic Pressure Release Assembly**

- 6.1.3 With the Dynamic Back Pressure Assembly open to atmosphere, flow nitrogen through the assembly at each specified flowrate. Record any back pressure on the appropriate data sheet. Allow a minimum of 15 seconds for the nitrogen flow to stabilize before taking back pressure measurement.
- 6.1.4 Perform an initial visual examination for vapor leaks at the nozzle and hose of the Phase II system to be tested. All leak sources shall be repaired or the component(s) removed and replaced prior to testing.
- 6.1.5 Pour a minimum of two (2) gallons of gasoline into each Phase II vapor return riser. The District's authorized representative may waive this requirement for facilities that have been in operation prior to the test. This gasoline may be introduced into the Phase II riser in any appropriate manner. Alternatively, a minimum of twenty gallons of gasoline may be introduced into the Phase II riser furthest from the gasoline storage tank,

provided that the riser is common to all products available at that dispenser. If product-specific risers are employed, a minimum of seven gallons, per product grade, may be introduced into the riser of each product which is furthest from the gasoline storage tank.

- 6.1.6 Allow fifteen (15) minutes for liquid in the vapor return piping to drain.
- 6.1.7 Completely drain any gasoline from the spout and bellows.
- 6.1.8 For those vapor piping configurations which utilize a condensate pot, drain the pot prior to testing.
- 6.1.9 The Phase I vapor poppet shall be propped open in such a manner that the valve is not damaged. This may be accomplished using a Dynamic Pressure Release Assembly as shown in Figure 27-2.

6.2 Alternate Method 2.

- 6.2.1 Assemble the test equipment as shown in Figures 27-1 and 27-2.
- 6.2.2 Open the Phase I vapor poppet for the affected tank(s).
- 6.2.3 Pour a minimum of two (2) gallons of gasoline into each Phase II vapor return riser. The Districts authorized representative may waive this requirement for facilities that have been in operation prior to the test. This gasoline may be introduced into the Phase II riser in any appropriate manner.

6.3 Alternate Method 3.

- 6.3.1 Assemble the Dynamic Back Pressure Test Assembly as shown in Figure 27-1.
- 6.3.2 Open the Phase I vapor poppet for the affected tank(s).
- 6.3.3 Pour a minimum of two (2) gallons of gasoline into each Phase II vapor return riser. The Districts authorized representative may waive this requirement for facilities that have been in operation prior to the test. This gasoline may be introduced into the Phase II riser in any appropriate manner.

6.4 Alternate Method 4.

- 6.4.1 Assemble the Capped "T" Assembly as shown in Figure 27-3.
- 6.4.2 Open the Phase I vapor poppet for the affected tank(s).
- 6.4.3 Pour a minimum of two (2) gallons of gasoline into each Phase II vapor return riser. The Districts authorized representative may waive this requirement for facilities that have been in operation prior to the test. This gasoline may be introduced into the Phase II riser in any appropriate manner.

6.5 Alternate Method 5.

- 6.5.1 Assemble the Torus Pressure Test Assembly as shown in Figure 27-4.
- 6.5.2 The Phase I vapor poppet shall remain closed during this test.

6.6 Alternate Method 6.

- 6.6.1 Assemble the Vent Pipe Pressure Assembly as shown in Figure 27-5.
- 6.6.2 Carefully remove the vent pipe pressure/vacuum (P/V) valve.
- 6.6.3 Open the Phase I vapor poppet for the affected tank(s).
- 6.6.4 Insure that the collection unit of the Phase II system is turned off.

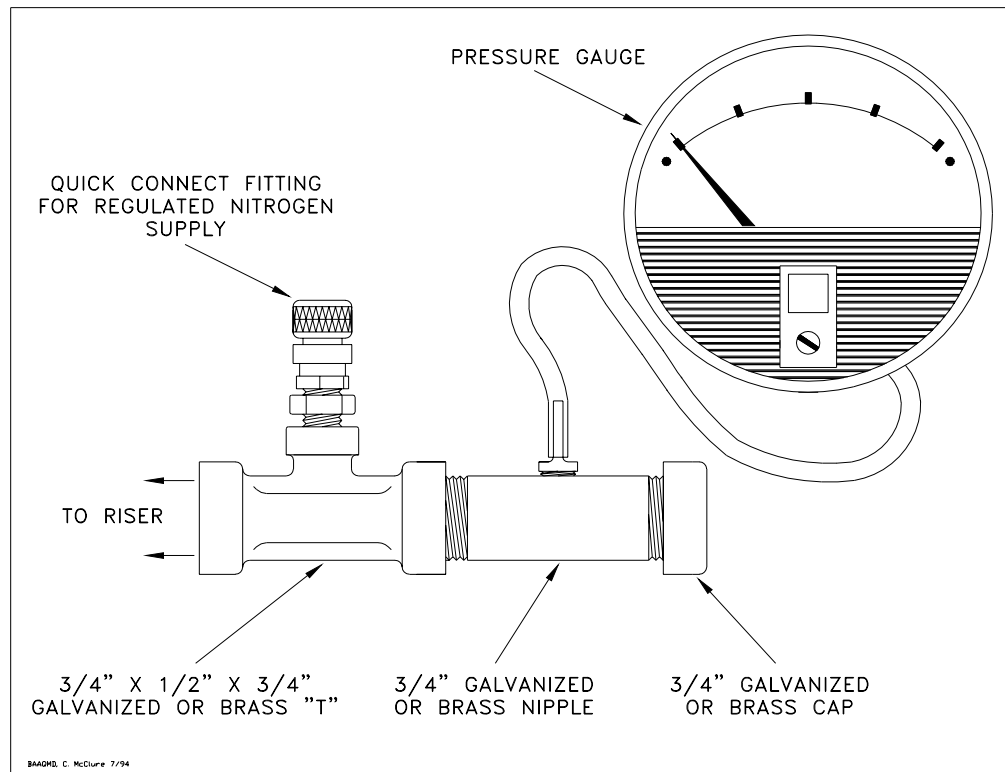
Figure 27-3**Capped "T" Assembly****7. TESTING**

7.1 Alternate Method 1. Insert the nozzle into the fillpipe of the Dynamic Back Pressure Test Unit, ensuring that a tight seal at the fillpipe/nozzle interface is achieved. This may be achieved by use of a "torus" shaped gasket as described in section 5.8.

- 7.1.1 Connect the nitrogen supply to the test assembly.
- 7.1.2 Open the nitrogen supply, set the delivery pressure to 5 psig, and use the flowmeter control valve to adjust the flowrate to lowest of the required nitrogen flowrates. Care must be taken to ensure that the initial flowrate through the rotameter does not exceed the lowest specified. If nitrogen has been introduced in excess of the minimum flowrate, then liquid must be introduced, pursuant to section 6.1.5, to conduct a valid test.
- 7.1.3 Allow a minimum of 15 seconds for the nitrogen flow to stabilize before taking backpressure readings. A pulsating gauge needle indicates nitrogen passing through a liquid obstruction in the vapor return system.

If this occurs, close the flow meter control valve, disengage the nozzle and redrain the nozzle and hose assembly. Re-engage the nozzle, open the flow meter control valve and repeat the test.

- 7.1.4** The following information shall be recorded on the field data sheet, as shown in Form 27-1:
- (a) Dispenser Number and Product Grade
 - (b) Nozzle Manufacturer and model
 - (c) Nitrogen flowrate, CFH
 - (d) Dynamic back pressure, inches H₂O
- 7.1.5** Repeat subsections 7.1.1 through 7.1.4 for all required nitrogen flowrates.
- 7.1.6** Close and replace the dust cover on the Phase I poppet.

7.2 Alternate Method 2. Phase II balance and Hirt systems which utilize both bellows-equipped nozzles and a fuel-activated remote vapor check valve may be tested using the following methodology.

- 7.2.1** Disconnect the vapor recovery hose from the remote vapor check valve. Test the nozzle/hose assembly pursuant to Section 7.1.1 through 7.1.4, and record the results on the field data sheet as shown in Form 27-2.
- 7.2.2** Disconnect the vapor check valve from the riser and connect a compatible "T" fitting to the riser as shown in Figure 27-3.
- 7.2.3** Connect the nitrogen supply to the "T" assembly.
- 7.2.4** Repeat Sections 7.1.2 through 7.1.5. In addition to the information required in Section 7.1.4, record both the make and model of the remote vapor check valve.
- 7.2.5** Record on the field data sheet the pressure drop across the remote vapor check valve. This data is available from the manufacturer.
- 7.2.6** Add the dynamic back pressures, for each required nitrogen flowrate, obtained from Sections 7.2.1, 7.2.4 and 7.2.5 as shown in Form 27-2.
- 7.2.7** Disconnect the "T" assembly and close and replace the dust cover on the Phase I poppet.

7.3 Alternate Method 3. Phase II balance and Hirt systems which use both bellows-equipped nozzles and those models of fuel-activated remote vapor check valves which can be disabled by removing the poppet on the fuel side may be tested using the following methodology. Phase II systems using an Emco-Wheaton A-228 remote vapor check valve **cannot** be tested using this method.

- 7.3.1** Carefully open the fuel side of the remote vapor check valve and remove the fuel poppet. Carefully replace the threaded plug on the fuel side of the valve.
- 7.3.2** Test the Phase II system pursuant to Sections 7.1.1 through 7.1.5, recording the data on the field data sheet shown in Form 27-1.

- 7.3.3** Carefully reassemble the remote vapor check valve by removing the plug on the fuel side and reinserting the fuel poppet. Replace the threaded fuel plug, taking care not to strip the threads.
- 7.3.4** Close and replace the dust cover on the Phase I poppet.

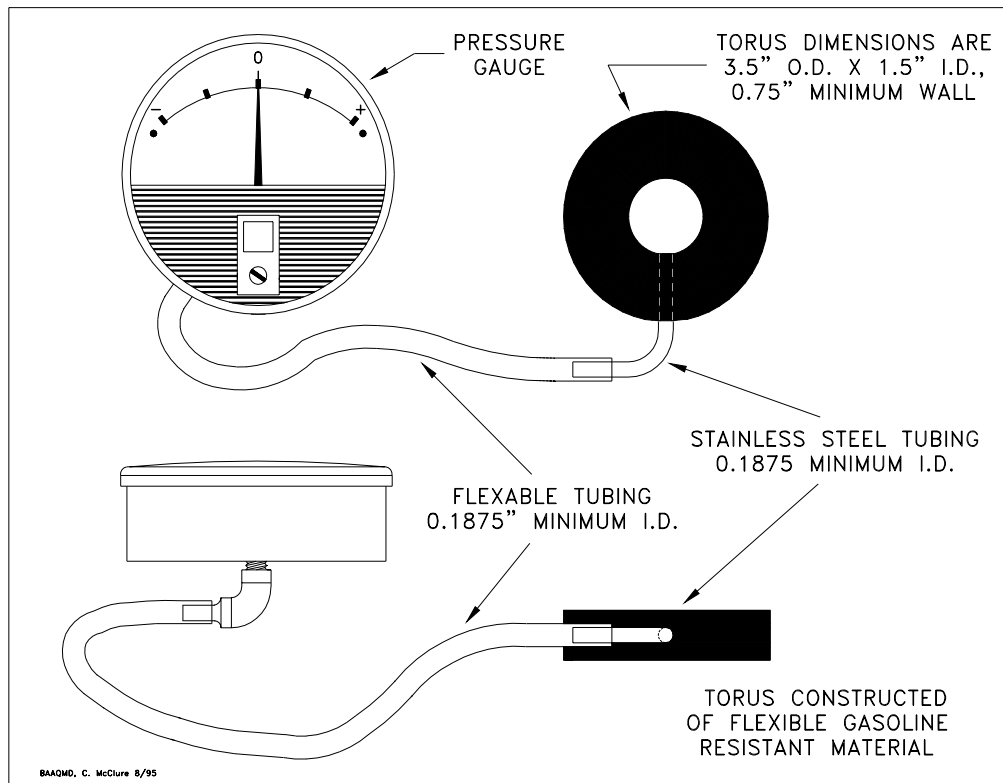
Figure 27-4**Torus Pressure Test Assembly**

7.4 Alternate Method 4. Those Phase II systems subject to regulatory limitations on the dynamic back pressure between the Phase II riser and gasoline storage tank may be tested using this methodology.

- 7.4.1** Disconnect the Phase II riser and install the "T" assembly as shown in Figure 27-3.
- 7.4.2** Connect the nitrogen supply to the "T" assembly.
- 7.4.3** Open the nitrogen supply, set the delivery pressure to 5 psig, and use the flowmeter control valve to adjust the flowrate to lowest of the required nitrogen flowrates. Care must be taken to ensure that the initial flowrate through the rotameter does not exceed the lowest specified in the Executive Order. If nitrogen has been introduced in excess of the minimum flowrate, then liquid must be introduced, pursuant to section 6.1.5, to conduct a valid test. Allow a minimum of 15 seconds for the nitrogen flow to stabilize before taking back pressure measurement.

- 7.4.4** A pulsating gauge needle indicates nitrogen passing through a liquid obstruction in the vapor return plumbing. If this occurs, the cause of the liquid trap must be corrected.
- 7.4.5** The following information shall be recorded on the field data sheet, as shown in Form 27-1:
- (a) Dispenser Number and Product Grade
 - (b) Nitrogen flowrate, CFH
 - (c) Dynamic back pressure, inches H₂O
- 7.4.6** Repeat subsections 7.4.3 through 7.4.5 for all required nitrogen flowrates.
- 7.4.7** Disconnect the "T" assembly and close and replace the dust cover on the Phase I poppet.
- 7.5 Alternate Method 5.** Those bellows-equipped Phase II systems subject to regulatory limitations on the dynamic back pressure at the nozzle/fillpipe interface during gasoline dispensing shall use the following methodology.
- 7.5.1** Assemble the Torus Pressure Test Assembly (Donut) as shown in Figure 27-4.
- 7.5.2** Insert the nozzle spout through the inner hole of the donut.
- 7.5.3** Insert and latch the nozzle in the vehicle fillpipe. Visually insure that a tight connection is made between the donut and fillpipe.
- 7.5.4** Activate the dispenser, set the nozzle hold-open latch on low, and after at least one gallon has been dispensed start the stopwatch. Dispense a minimum of four gallons of gasoline. Use the stopwatch to accurately time the dispensing rate. The following data shall be recorded on the field data sheet as shown in Form 27-4:
- (a) Nozzle number and gasoline grade
 - (b) Gallons dispensed during test
 - (c) Maximum dynamic back pressure, inches H₂O
 - (d) Minimum dynamic back pressure, inches H₂O
 - (e) The average dispensing rate, gallons per minute
- 7.5.5** This Alternate Method shall only be conducted with the Phase I vapor poppet closed, since gasoline is being dispensed during the test.
- 7.6 Alternate Method 6.** Those Phase II systems which utilize an incinerator shall conduct this test in conjunction with the applicable of Alternate Method 1, 2, 3, 4, or 5. This procedure verifies proper drainage of gasoline from the base of the vent pipe to the gasoline storage tank.
- 7.6.1** After verifying compliance with the dynamic back pressure standards, pursuant to the applicable of Alternate Methods 1, 2, 3, or 4, close the Phase I vapor poppet.
- 7.6.2** Remove the pressure/vacuum (P/V) valve(s) from each vent pipe.
- 7.6.3** Carefully pour a minimum of five gallons of gasoline down each vent pipe, wait at least 15 minutes for the gasoline to drain.

- 7.6.4 Install the Vent Pipe Pressure Assembly as shown in Figure 27-5. Open the Phase I poppet(s) on all affected tanks.
- 7.6.5 Connect the nitrogen supply to the Vent Pipe Pressure Assembly.
- 7.6.6 Open the nitrogen supply and adjust the flowrate to 60 CFH.
- 7.6.7 After a minimum of thirty seconds, record the dynamic back pressure.
- 7.6.8 A dynamic back pressure, from the top of the vent pipe to the storage tank, of less than 0.5 inches H₂O shall be considered acceptable.
- 7.6.9 Remove the Vent Pipe Pressure Assembly, carefully reinstall the P/V valve, and close the Phase I poppets.
- 7.6.10 Repeat steps 7.6.6 through 7.6.9 for each vent stack that has a P/V valve.
- 7.6.11 Remove the vapor recovery elbow or Dynamic Pressure Release Assembly from the Phase I poppet and replace the dust cap.

Figure 27-5

Vent Pipe Pressure Assembly

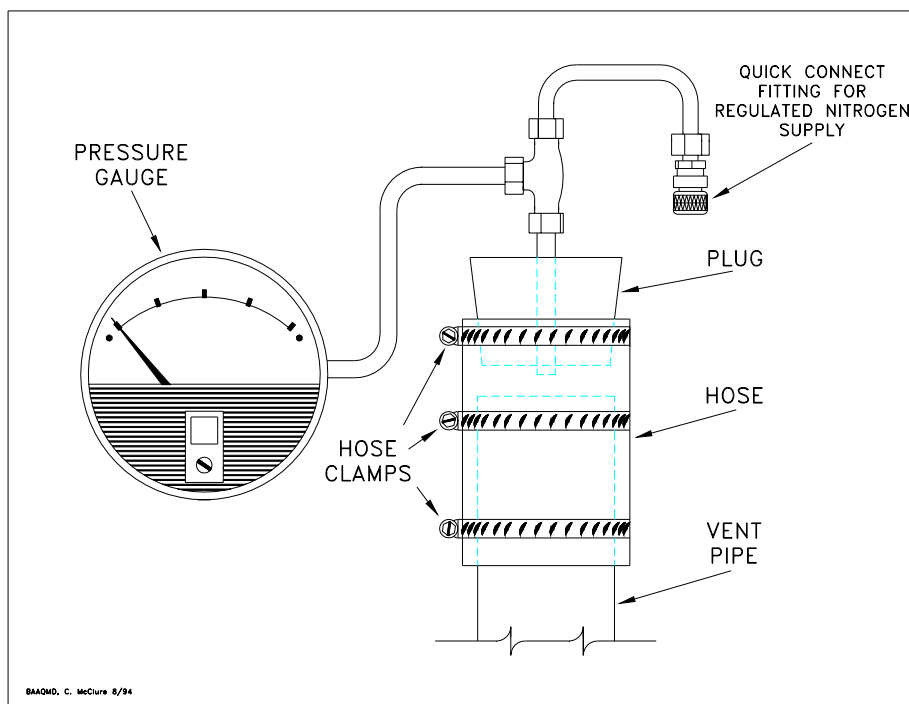

8. REPORTING

8.1 Results of the dynamic back pressure test shall be reported as shown below:

- 8.1.1 Alternate Method 1 Use Form 27-1
- 8.1.2 Alternate Method 2 Use Form 27-2
- 8.1.3 Alternate Method 3 Use Form 27-1
- 8.1.4 Alternate Method 4 Use Form 27-3
- 8.1.5 Alternate Method 5 Use Form 27-4

8.1.6 Alternate Method 6

Include on applicable of Forms 27-1, 2, 3, or 4

Form 27-4

Distribution: Firm Permit Services Enforcement Services Technical Services Planning Requester DAPCO	<p>BAY AREA AIR QUALITY MANAGEMENT DISTRICT</p> <p><i>939 Ellis Street San Francisco, California 94109 (415) 771-6000</i></p> <p>Summary of Source Test Results</p>	Report No.: _____ Test Date: _____ Test Times: _____ Run A: _____
---	---	--

Source Information		BAAQMD Representatives
Firm Name and Address	Firm Representative and Title	Source Test Engineers
	Phone No. ()	
Permit Conditions:	Source: GDF Vapor Recovery	Permit Services Division/Enforcement Division
	BAAQMD GDF # _____	Test Requested By:
	BAAQMD A/C # _____	
Operating Parameters:		
Applicable Regulations:		VN Recommended:

Sources Test Results and Comments:

<u>Nozzle #</u>	<u>Gas Grade</u>	<u>Gallons Dispensed</u>	Dynamic Back Pressure, In. H ₂ O		
			<u>Max. B.P.</u>	<u>Min. B.P.</u>	<u>Rate, GPM</u>
_____	_____	_____	_____	_____	_____
_____	_____	_____	_____	_____	_____
_____	_____	_____	_____	_____	_____
_____	_____	_____	_____	_____	_____
_____	_____	_____	_____	_____	_____
_____	_____	_____	_____	_____	_____
_____	_____	_____	_____	_____	_____
_____	_____	_____	_____	_____	_____
_____	_____	_____	_____	_____	_____
_____	_____	_____	_____	_____	_____
_____	_____	_____	_____	_____	_____
_____	_____	_____	_____	_____	_____
_____	_____	_____	_____	_____	_____
_____	_____	_____	_____	_____	_____
_____	_____	_____	_____	_____	_____
_____	_____	_____	_____	_____	_____
_____	_____	_____	_____	_____	_____
_____	_____	_____	_____	_____	_____
_____	_____	_____	_____	_____	_____
_____	_____	_____	_____	_____	_____
_____	_____	_____	_____	_____	_____

Results Received by _____	Date _____	Results Reviewed by _____	Date _____	Results Approved/Disapproved _____
---------------------------	------------	---------------------------	------------	------------------------------------