



Board of Directors  
MEETING  
May 6, 2026

**MEETING LOCATION(S) FOR IN-PERSON ATTENDANCE BY  
BOARD MEMBERS AND MEMBERS OF THE PUBLIC**

**Bay Area Metro Center  
1st Floor Board Room  
375 Beale St.  
San Francisco, CA 94105**

**Office of Contra Costa County  
Supervisor John Gioia  
Conference Room  
11780 San Pablo Ave., Suite D  
El Cerrito, CA 94530**

**Alameda County Supervisor  
David Haubert  
246 Argonne Way  
Long Beach, CA 90803**

**Alameda County  
Board of Supervisors District 3  
101 Callan Ave., Suite 103  
San Leandro, CA 94577**

**San Mateo County Transit District  
2nd Floor Auditorium  
1250 San Carlos Ave.  
San Carlos, CA 94070**

**Solano County Administration Building  
675 N. Texas St. Room A168  
Fairfield, CA 94533**

**San Mateo County Supervisor  
Ray Mueller  
270 Capistrano Rd., Unit 6  
Half Moon Bay, CA 94019**

**THE FOLLOWING STREAMING OPTIONS WILL ALSO BE PROVIDED**

**These streaming options are provided for convenience only. In the event that streaming connections malfunction for any reason, the Board of Directors reserves the right to conduct the meeting without remote webcast and/or Zoom access.**

**The public may observe this meeting through the webcast by clicking the link available on the air district's agenda webpage at <https://www.baaqmd.gov/bodagendas>**

**Members of the public may participate remotely via Zoom at <https://bayareametro.zoom.us/j/86241055393> or may join Zoom by phone by dialing (669) 900-6833 or (408) 638-0968.**

**The Webinar ID for this meeting is:**

**[862 4105 5393](https://bayareametro.zoom.us/j/86241055393)**

## **PUBLIC COMMENT ON AGENDA ITEMS**

**The public may comment on each item on the agenda as the item is taken up. Members of the public who wish to speak on a matter on the agenda will have two minutes each to address the Board on that agenda item, unless a different time limit is established by the Chair. No speaker who has already spoken on an item will be entitled to speak to that item again.**

**Written public comments can be emailed to [comments@baaqmd.gov](mailto:comments@baaqmd.gov) or through the Air District's website via the "Submit a Comment" feature for this meeting. Written public comments emailed by 10:00 a.m. on the business day prior to this meeting will be provided to the Board members in advance of the meeting. Written public comments emailed after that deadline will be provided to the Board members following the meeting's adjournment. Unless directed by the Chair, written public comments will not be read aloud during the meeting.**

**The Board welcomes comments, including criticism, about the policies, procedures, programs, or services of the Air District, or of the acts or omissions of the Board.**

**Speakers shall not use threatening, profane, or abusive language which disrupts, disturbs, or otherwise impedes the orderly conduct of a Board meeting. The Air District is committed to maintaining a workplace free of unlawful harassment and is mindful that Air District staff regularly attend Board meetings. Discriminatory statements or conduct that would potentially violate the Fair Employment and Housing Act – i.e., statements or conduct that is hostile, intimidating, oppressive, or abusive – is *per se* disruptive to a meeting and will not be tolerated.**

# BOARD OF DIRECTORS MEETING AGENDA

WEDNESDAY, MAY 6, 2026

10:00 AM

Chairperson, Lynda Hopkins

1. **Call to Order - Roll Call**

*The Board Chair shall call the meeting to order and the Clerk of the Boards shall take roll of the Board members.*

2. **Pledge of Allegiance**

**CLOSED SESSION**

**NOTE FOR MEMBERS OF THE PUBLIC INTERESTED IN ATTENDING OPEN SESSION ITEMS: OPEN SESSION WILL NOT RESUME BEFORE 11:00 A.M.**

3. Conference with Legal Counsel re Existing Litigation Pursuant to Government Code Sections 54956.9(a) and (d)(1)

*Pursuant to Government Code Sections 54956.9(a) and (d)(1), the Board of Directors will meet in closed session with legal counsel to discuss the following cases:*

*Stephen (Rex) Sanders v. Bay Area Air Quality Management District, Northern District of California Case No. 23-cv-04416-RFL;*

*Terri Levels v. Bay Area Air Quality Management District, Northern District of California Case No. 23-cv-04432-RFL;*

*Lewis Letang v. Bay Area Air Quality Management District, Northern District of California Case No. 24-cv-01316-RFL;*

*Rochele Henderson v. Bay Area Air Quality Management District, Northern District of California Case No. 24-cv-01460-RFL;*

*Veronica Eady v. Bay Area Air Quality Management District, Northern District of California Case No. 24-cv-07000-RFL; and*

*Vanessa Johnson v. Bay Area Air Quality Management District, Northern District of California Case No. 24-cv-06276-RFL.*

4. Conference with Legal Counsel re Anticipated Litigation Pursuant to Government Code Sections 54956.9(a), (d)(2) and (e)(3)

*Pursuant to Government Code Sections 54956.9(a), (d)(2) and (e)(3), the Board of Directors will meet in closed session with legal counsel to discuss a significant exposure to litigation regarding the government code claim of Tinisha Youngs received by the Air District on March 23, 2026.*

5. Public Employee Evaluation Pursuant to Government Code Section 54957(b)(1)

*Title: Executive Officer/APCO*

6. Public Employee Evaluation Pursuant to Government Code Section 54957(b)(1)

*Title: General Counsel*

7. Conference with Labor Negotiators Pursuant to Government Code Section 54957.6

*Agency Designated Representatives:*

*Laura A. Izon, Atkinson, Andelson, Loya, Ruud & Romo*

*Hyacinth Hinojosa, Deputy Executive Officer of Finance and Administration*

*Lisa Baker, Director of Human Resources*

*Employee Organization: BAAQMD Employees Association*

8. Conference with Labor Negotiators Pursuant to Government Code Section 54957.6

*Agency Designated Representatives:*

*Laura A. Izon, Atkinson, Andelson, Loya, Ruud & Romo*

*Hyacinth Hinojosa, Deputy Executive Officer of Finance and Administration*

*Lisa Baker, Director of Human Resources*

*Employee Organization: Attorney Management Unit (EA-AMU)*

**OPEN SESSION - OPEN SESSION WILL NOT RESUME BEFORE 11:00 A.M.**

**OPENING ITEM(S)**

9. **Special Orders of the Day**

## **CONSENT CALENDAR (Items 10 - 26)**

*The Consent Calendar consists of routine items that may be approved together as a group by one action of the Board. Any Board member or member of the public may request that an item be removed and considered separately.*

10. Approval of the Draft Minutes of the Board of Directors Meeting of April 1, 2026

*The Board of Directors will consider approving the Draft Minutes of the Board of Directors Meeting of April 1, 2026.*

11. Board Communications Received from April 1, 2026, through May 5, 2026

*A copy of communications directed to the Board of Directors received by the Air District from April 1, 2026, through May 5, 2026, if any, will be distributed to the Board Members by way of email.*

12. Notices of Violations Issued and Settlements in Excess of \$10,000 in the Month of March 2026

*In accordance with Board Resolution No. 2012-08, staff will provide the Board of Directors with a list of all Notices of Violations issued, and all settlements for amounts in excess of \$10,000, during the month of March 2026.*

13. Personnel Out-of-State Business Travel Report for March 2026

*In accordance with Section 1.1.3 of the Air District's Employee Travel and Business Expense Policy, the Board of Directors will be notified of Air District personnel who have traveled on out-of-state business.*

14. Approval of an Amendment to the Employment Agreement for General Counsel

*The Board of Directors will consider approving an amendment to the Employment Agreement for General Counsel. This item will be presented by Lynda Hopkins, Board Chairperson.*

15. Approval of an Amendment to the Employment Agreement for Executive Officer/APCO

*The Board of Directors will consider approving an amendment to the Employment Agreement for the Executive Officer/APCO. This item will be presented by Lynda Hopkins, Board Chairperson.*

16. Authorization to Amend Contract with Acterra for Bayview Hunters Point/Southeast San Francisco Assembly Bill 617 Community Steering Committee Support

*The Board of Directors will consider authorizing the Executive Officer/APCO to amend the contract with Acterra to extend the end date of the contract term from May 31, 2026, to September 30, 2027, and to increase the total not-to-exceed dollar amount of the agreement by \$391,208, from \$199,000 to \$590,208. The changes will support continuation of meeting logistics support for the Bayview Hunters Point/Southeast San Francisco Assembly Bill 617 Community Steering Committee.*

17. Authorization to Amend Contract with Renne Public Law Group for Legal Services Related to Labor and Employment Issues

*The Board of Directors will consider (i) authorizing the General Counsel to amend the Air District's legal services agreement with Renne Public Law Group to increase the maximum dollar amount of the agreement by \$1,000,000, from \$4,050,000 to \$5,050,000, for legal services related to labor and employment issues, including general legal advice and counseling and representation in ongoing personnel litigation; and (ii) authorizing the transfer of \$250,000 from Outside Counsel Litigation Support Designated Reserves to Program 205 – Litigation to cover a portion of certain litigation defense costs that is not being covered by insurance. Approximately 75% of the attorneys fees related to that personnel litigation are being paid for by insurance, subject to a reservation of rights. But approximately 25% are not being covered, giving rise to the need for the \$250,000 transfer from designated reserves.*

*The Board most recently approved this legal services agreement for a total not-to-exceed amount of \$3,850,000 in July 2025. In April 2026, under General Counsel authority pursuant to Section 9.4(g) of the Administrative Code, the Air District issued an amendment increasing the total not-to-exceed amount to \$4,050,000. The Board will consider a further amendment that would increase the not-to-exceed amount by an additional \$1,000,000, from \$4,050,000 to \$5,050,000, with the majority of the litigation costs to be covered by insurance subject to a reservation of rights.*

18. Authorization to Execute a Sponsorship Contract with the San Francisco Pride Parade

*The Board of Directors will consider authorizing the Executive Officer/APCO to execute a sponsorship contract with the San Francisco Pride Parade in an amount not to exceed \$45,000 to support the Air District's participation in the parade, increase visibility of its Spare the Air program and support the LGBTQ+ community.*

19. Transportation Fund for Clean Air 40% Fund Allocation and Expenditure Plans for Fiscal Year Ending 2027

*The Board of Directors will consider (i) approving the proposed allocation and expenditure plans for the estimated new Transportation Fund for Clean Air (TFCA) revenue to each of the nine Administering Agencies for Fiscal Year Ending (FYE) 2027; (ii) approving the proposed allocation of additional funding for bikeway and bike parking projects to each Administering Agency; and (iii) authorizing the Executive Officer/APCO to enter into funding agreements with the Administering Agencies for Transportation Fund for Clean Air revenues. The Policy, Grants, and Technology Committee recommended this item at its meeting on April 15, 2026.*

20. Consideration of State Legislation

*The Board of Directors will consider adopting positions on pending state legislative bills where appropriate, including, but not limited to the following bills:*

*Recommendations from the Policy, Grants, and Technology Committee at its meeting on April 15, 2026:*

**SUPPORT**

*Assembly Bill 2349 (Solache)  
Senate Bill 1159 (Cabaldon)*

**OPPOSE**

*Assembly Bill 2057 (DeMaio)  
Assembly Bill 2102 (DeMaio)  
Senate Bill 1039 (Grove)  
Senate Bill 1075 (Reyes)*

*Recommendation from Air District staff based on amended bill language:*

**OPPOSE UNLESS AMENDED**

*Senate Bill 1075 (Reyes)*

21. Report of the Advisory Council Meeting of March 16, 2026

*The Board of Directors will receive a Report of the Advisory Council Meeting of March 16, 2026.*

*For the full Council agenda packet and materials, click on the link below:*

[www.baaqmd.gov/en/about-the-air-district/advisory-council/agendasreports](http://www.baaqmd.gov/en/about-the-air-district/advisory-council/agendasreports)

22. Report of the Community Advisory Council Meeting of March 19, 2026

*The Board of Directors will receive a report of the Community Advisory Council Meeting of March 19, 2026.*

*For the full Council agenda packet and materials, click on the link below:*

[www.baaqmd.gov/en/about-the-air-district/community-advisory-council/agendasreports](http://www.baaqmd.gov/en/about-the-air-district/community-advisory-council/agendasreports)

23. Report of the Stationary Source Committee Meeting of April 8, 2026

*The Board of Directors will receive a report of the Stationary Source Committee Meeting of April 8, 2026.*

*For the full Committee agenda packet and materials, click on the link below:*

[www.baaqmd.gov/bodagendas](http://www.baaqmd.gov/bodagendas)

24. Report of the Community Equity, Health, and Justice Committee Meeting of April 8, 2026

*The Board of Directors will receive a report of the Community Equity, Health, and Justice Committee Meeting of April 8, 2026.*

*For the full Committee agenda packet and materials, click on the link below:*

[www.baaqmd.gov/bodagendas](http://www.baaqmd.gov/bodagendas)

25. Report of the Finance and Administration Committee Meeting of April 15, 2026

*The Board of Directors will receive a report of the Finance and Administration Committee Meeting of April 15, 2026.*

*For the full Committee agenda packet and materials, click on the link below:*

[www.baaqmd.gov/bodagendas](http://www.baaqmd.gov/bodagendas)

26. Report of the Policy, Grants, and Technology Committee Meeting of April 15, 2026

*The Board of Directors will receive a report of the Policy, Grants, and Technology Committee Meeting of April 15, 2026.*

*For the full Committee agenda packet and materials, click on the link below:*

[www.baaqmd.gov/bodagendas](http://www.baaqmd.gov/bodagendas)

## **DISCUSSION ITEM**

27. Rule 9-6 Regulatory Overview and Discussion of Flexibility and Affordability Amendments for Zero-NOx Water Heaters

*The Board of Directors will discuss potential flexibility and affordability amendments to Rule 9-6 for small water heaters and provide direction to staff. The Regulatory Overview for Rule 9-6, released publicly on April 13, was intended to provide additional context on Air District staff's process to date and current recommendations. This item will be presented by Jennifer Lam, Manager in the Regulatory Development Division. Note that public comment time may be limited to 90 seconds per commenter or other shortened time period, if needed, to ensure the Board of Directors can complete public comments on this item.*

*The written materials for this item will be available in Spanish, Chinese, Tagalog, and Vietnamese at <https://www.baaqmd.gov/building-appliances>.*

## **OTHER BUSINESS**

### 28. Public Comment on Non-Agenda Matters

*Pursuant to Government Code Section 54954.3, members of the public who wish to speak on matters not on the agenda will be given an opportunity to address the Board of Directors. Members of the public will have two minutes each to address the Board, unless a different time limit is established by the Chair. The Board welcomes comments, including criticism, about the policies, procedures, programs, or services of the Air District, or of the acts or omissions of the Board. Speakers shall not use threatening, profane, or abusive language which disrupts, disturbs, or otherwise impedes the orderly conduct of a Board meeting. The Air District is committed to maintaining a workplace free of unlawful harassment and is mindful that Air District staff regularly attend Board meetings. Discriminatory statements or conduct that would potentially violate the Fair Employment and Housing Act – i.e., statements or conduct that is hostile, intimidating, oppressive, or abusive – is per se disruptive to a meeting and will not be tolerated.*

### 29. Board Member Comments

*Any member of the Board, or its staff, on their own initiative or in response to questions posed by the public, may: ask a question for clarification, make a brief announcement or report on their own activities, provide a reference to staff regarding factual information, request staff to report back at a subsequent meeting concerning any matter or take action to direct staff to place a matter of business on a future agenda. (Gov't Code § 54954.2)*

### 30. Report of the Executive Officer/APCO

### 31. Chairperson's Report

### 32. Time and Place of Next Meeting

*Wednesday, June 3, 2026, at 10:00 a.m. The meeting will be held in-person at the Bay Area Metro Center. Members of the Board of Directors must attend in person at the Bay Area Metro Center; members of the public will be able to attend in person or virtually via webcast.*

### 33. Adjournment

*The Board meeting shall be adjourned by the Board Chair.*

**CONTACT:**

**MANAGER, EXECUTIVE OPERATIONS**  
**375 BEALE STREET, SAN FRANCISCO, CA 94105**  
[vjohnson@baaqmd.gov](mailto:vjohnson@baaqmd.gov)

**(415) 749-4941**  
**FAX: (415) 928-8560**  
**Air District homepage:**  
[www.baaqmd.gov](http://www.baaqmd.gov)

- Any writing relating to an open session item on this Agenda that is distributed to all, or a majority of all, members of the body less than 72 hours before the meeting shall be made available at the Air District's offices at 375 Beale Street, Suite 600, San Francisco, CA 94105, at the time such writing is made available to all, or a majority of all, members of that body.

**Accessibility and Non-Discrimination Policy**

The Bay Area Air Quality Management District (Air District) does not discriminate on the basis of race, national origin, ethnic group identification, ancestry, religion, age, sex, sexual orientation, gender identity, gender expression, color, genetic information, medical condition, or mental or physical disability, or any other attribute or belief protected by law.

It is the Air District's policy to provide fair and equal access to the benefits of a program or activity administered by Air District. The Air District will not tolerate discrimination against any person(s) seeking to participate in, or receive the benefits of, any program or activity offered or conducted by the Air District. Members of the public who believe they or others were unlawfully denied full and equal access to an Air District program or activity may file a discrimination complaint under this policy. This non-discrimination policy also applies to other people or entities affiliated with Air District, including contractors or grantees that the Air District utilizes to provide benefits and services to members of the public.

Auxiliary aids and services including, for example, qualified interpreters and/or listening devices, to individuals who are deaf or hard of hearing, and to other individuals as necessary to ensure effective communication or an equal opportunity to participate fully in the benefits, activities, programs, and services will be provided by the Air District in a timely manner and in such a way as to protect the privacy and independence of the individual. Please contact the Non-Discrimination Coordinator identified below at least three days in advance of a meeting so that arrangements can be made accordingly.

If you believe discrimination has occurred with respect to an Air District program or activity, you may contact the Non-Discrimination Coordinator identified below or visit our website at [www.baaqmd.gov/accessibility](http://www.baaqmd.gov/accessibility) to learn how and where to file a complaint of discrimination.

Questions regarding this Policy should be directed to the Air District's Non-Discrimination Coordinator, Kimberly Leefatt, Civil Rights Officer at 415-749-4610 or by email at [non-discriminationcoordinator@baaqmd.gov](mailto:non-discriminationcoordinator@baaqmd.gov).

**BAY AREA AIR DISTRICT  
375 BEALE STREET, SAN FRANCISCO, CA 94105  
FOR QUESTIONS PLEASE CALL (415) 749-4941**

**EXECUTIVE OFFICE:  
MONTHLY CALENDAR OF AIR DISTRICT MEETINGS**

**MAY 2026**

| <u>TYPE OF MEETING</u>  | <u>DAY</u> | <u>DATE</u> | <u>TIME</u> | <u>ROOM</u>                             |
|---|------------|-------------|-------------|---|
| Advisory Council Meeting<br>- CANCELLED                               | Monday     | 4           | 9:00 a.m.   | 1 <sup>st</sup> Floor Board Room        |
| Board of Directors Meeting  | Wednesday  | 6           | 10:00 a.m.  | 1 <sup>st</sup> Floor Board Room        |
| Board of Directors Stationary Source Committee                        | Wednesday  | 13          | 10:00 a.m.  | 1 <sup>st</sup> Floor, Yerba Buena Room |
| Board of Directors Community Equity, Health, and Justice Committee    | Wednesday  | 13          | 1:00 p.m.   | 1 <sup>st</sup> Floor, Yerba Buena Room |
| Board of Directors Policy, Grants and Technology Committee            | Wednesday  | 20          | 10:00 a.m.  | 1 <sup>st</sup> Floor Board Room        |
| Board of Directors Finance and Administration Committee<br>-CANCELLED | Wednesday  | 20          | 1:00 p.m.   | 1 <sup>st</sup> Floor Board Room        |
| Community Advisory Council Meeting                                    | Thursday   | 21          | 6:00 p.m.   | 1 <sup>st</sup> Floor Board Room        |

**JUNE 2026**

| <u>TYPE OF MEETING</u>   | <u>DAY</u> | <u>DATE</u> | <u>TIME</u> | <u>ROOM</u>                             |
|--|------------|-------------|-------------|---|
| Board of Directors Meeting   | Wednesday  | 3           | 10:00 a.m.  | 1 <sup>st</sup> Floor Board Room        |
| Board of Directors Stationary Source Committee                     | Wednesday  | 10          | 10:00 a.m.  | 1 <sup>st</sup> Floor, Yerba Buena Room |
| Board of Directors Community Equity, Health, and Justice Committee | Wednesday  | 10          | 1:00 p.m.   | 1 <sup>st</sup> Floor, Yerba Buena Room |
| Advisory Council Meeting   | Monday     | 15          | 9:00 a.m.   | 1 <sup>st</sup> Floor Board Room        |

## JUNE 2026

| <u>TYPE OF MEETING</u>                                     | <u>DAY</u> | <u>DATE</u> | <u>TIME</u> | <u>ROOM</u>                      |
|--|------------|-------------|-------------|----------------------------------|
| Board of Directors Policy, Grants and Technology Committee | Wednesday  | 17          | 10:00 a.m.  | 1 <sup>st</sup> Floor Board Room |
| Board of Directors Finance and Administration Committee    | Wednesday  | 17          | 1:00 p.m.   | 1 <sup>st</sup> Floor Board Room |
| MV 4/29/26 – 2:33 p.m.                                     |            |             |             | G/Board/Executive Office/Moncal  |

**BAY AREA AIR DISTRICT**  
Memorandum

To: Chairperson Lynda Hopkins and Members  
of the Board of Directors

From: Philip M. Fine  
Executive Officer/APCO

Date: May 6, 2026

Re: Approval of the Draft Minutes of the Board of Directors Meeting of April 1,  
2026

RECOMMENDED ACTION

Approve the Draft Minutes of the Board of Directors Meeting of April 1, 2026.

BACKGROUND

None.

DISCUSSION

Attached for your review and approval are the Draft Minutes of the Board of Directors Meeting of April 1, 2026.

BUDGET CONSIDERATION/FINANCIAL IMPACT

None.

Respectfully submitted,

Philip M. Fine  
Executive Officer/APCO

Prepared by: Marcy Hiratzka  
Reviewed by: Vanessa Johnson

ATTACHMENT(S):

1. Draft Minutes of the Board of Directors Meeting of April 1, 2026

Bay Area Air District  
375 Beale Street, Suite 600  
San Francisco, CA 94105  
(415) 749-5073

Board of Directors Meeting  
Wednesday, April 1, 2026

## **DRAFT MINUTES**

*This meeting was webcast, and a video recording is available on the website of the Bay Area Air District at [www.baaqmd.gov/bodagendas](http://www.baaqmd.gov/bodagendas)*

### **CALL TO ORDER**

1. **Opening Comments:** Board of Directors (Board) Chairperson, Lynda Hopkins, called the meeting to order at 10:00 a.m.

#### **Roll Call:**

Present, In-Person (Bay Area Metro Center, 375 Beale Street, 1<sup>st</sup> Floor Board Room, San Francisco, CA, 94105): Chairperson Lynda Hopkins; Vice Chairperson Vicki Veenker; and Directors Dionne Adams, Ken Carlson, Juan González III, Tyrone Jue, Gabe Quinto, Mark Salinas, Linda Sell, Lena Tam, Shamann Walton, and Steve Young.

Present, In-Person Satellite Location (Napa County Administration Building, 1195 Third Street, Suite 310, County Executive's Office, Napa, CA 94559): Director Joelle Gallagher.

Present, In-Person Satellite Location (San Mateo County Board of Supervisors' Office, 5th Floor, 500 County Center, Redwood City, CA 94063): Directors Noelia Corzo, Rico E. Medina, and Ray Mueller.

Present, In-Person Satellite Location (Santa Rosa Junior College Campus, Doyle Library, Room 148, 1501 Mendocino Ave., Santa Rosa, CA 95401): Director Brian Barnacle.

Present, In-Person Satellite Location (Office of Contra Costa County Supervisor John Gioia, Conference Room, 11780 San Pablo Ave., Suite D, El Cerrito, CA 94530): Director John Gioia.

Present, In-Person Satellite Location (Office of Alameda County Supervisor David Haubert, Scott Haggerty House, 4501 Pleasanton Avenue, Pleasanton, CA 94566): Director David Haubert.

Absent: Directors Margaret Abe-Koga, Monica Brown, Brian Colbert, Otto Lee, Bilal Mahmood.

- 2. **PLEDGE OF ALLEGIANCE**
- 3. **SPECIAL ORDERS OF THE DAY (OUT OF ORDER, ITEM 6)**

Chair Hopkins welcomed the following new employees: Taylor Boutelle, Staff Specialist II in the Civil Rights Office; Jerold Brito, Air Quality Specialist II in the Regulatory Development Division; Reilly Carlson, Air Quality Engineer I in the Engineering Division; Kathryn Christopherson, Senior Analyst in the Human Resources Division; Brian LaFranchi, Senior Air Quality Specialist in the Meteorology and Measurement Division; Kimberly Leefatt, Civil Rights Officer; Tim McConiga, Systems Analyst in the Enterprise Technology Solutions Division; Sebrina Neal, Manager in the Information Services Division; Randyl Pamphlet, Executive Assistant II in the Executive Office; Seng Saechao, Administrative Assistant II in the Strategic Incentives Division; and Adrian Wong, Environmental Justice Law Fellow in the Legal Division; Jamie Jefferson, Assistant Counsel II in the Legal Division. Chair Hopkins also congratulated Pon Phithaksounthone for his promotion to Supervising Air Quality Engineer in the Source Test Division.

**CLOSED SESSION (ITEMS 3 – 5) (10:19 a.m.)**

Public Comments

No requests received.

- 4. **CONFERENCE WITH LEGAL COUNSEL RE INITIATION OF LITIGATION (GOVERNMENT CODE SECTIONS 54956.9(a) AND (d)(4)) (ITEM 3)**

Pursuant to Government Code Sections 54956.9(a) and (d)(4), the Board of Directors met in Closed Session with Legal Counsel to consider whether to initiate litigation: Two cases.

**Reportable Action:** Alexander Crockett, General Counsel, announced that there was no reportable action for this item.

- 5. **CONFERENCE WITH LEGAL COUNSEL RE ANTICIPATED LITIGATION PURSUANT TO GOVERNMENT CODE SECTIONS 54956.9(a), (d)(2) AND (E)(3) (ITEM 4)**

Pursuant to Government Code Sections 54956.9(a), (d)(2) and (e)(3), the Board of Directors met in Closed Session with Legal Counsel to discuss a significant exposure to litigation regarding the government code claim of Anthony Domingo Bico received by the Air District on February 27, 2026.

**Reportable Action:** Mr. Crockett announced that there was no reportable action for this item.

6. **CONFERENCE WITH LABOR NEGOTIATORS PURSUANT TO GOVERNMENT CODE SECTION 54957.6 (ITEM 5)**

Agency Designated Representatives:

Laura A. Izon, Atkinson, Andelson, Loya, Ruud & Romo

Hyacinth Hinojosa, Deputy Executive Officer of Finance and Administration

Lisa Baker, Director of Human Resources

Employee Organization: BAAQMD Employees Association

**Reportable Action:** Mr. Crockett announced that there was no reportable action for this item.

**OPEN SESSION (11:00 a.m.)**

**At this time, because many members of the public arrived in person in the morning to give Public Comments on Non-Agenda Matters (Item 19), Chair Hopkins allowed members of the public to give their comments immediately, rather than wait for Item 19 later in the agenda. Chair Hopkins also provided a further opportunity at Item 19 later in the agenda for members of the public who came later (see below).**

**Public Comments on Non-Agenda Items**

Public comments were given by Mark Williams, Environmental Justice League; Dr. Jeann McDougald, Fairfield resident; Tyree, San Francisco resident; Rochelle Hall, San Francisco resident; Brittany Bellamy, Oakland resident; Ajanae Young, San Leandro resident; Antonio Silva, Alameda County resident; C. Parker, Oakland resident; Charmaine Robinson; Tina Flores, Contra Costa County resident; Nina Hall, San Francisco resident; Mia, San Leandro resident; Joy Johnson, Hayward resident; Chloe Simon Ward; <male name unintelligible>; Gerald, Hayward resident; Kadeem Cypress, Vallejo resident; Justice Alford, Vallejo resident; Hon. Carolyn Wysinger, El Cerrito City Councilmember; Drew Sage, Berkeley resident; Melanie Davis, Oakland resident; Gina Alexander. El Sobrante resident; Amina, Oakland resident; Sariah, Oakland resident; Evelyn Darnes; Yvonne Eashman, Richmond resident; Kathy Kerridge, Benicia resident; Yassi K, Building Decarbonization Coalition; Marina Munoz, Oakland resident.

**CONSENT CALENDAR (ITEMS 7 – 13)**

7. Approval of the Draft Minutes of the Board of Directors Meeting of March 4, 2026
8. Board Communications Received from March 4, 2026, through March 31, 2026
9. Notices of Violations Issued and Settlements in Excess of \$10,000 in the Month of February 2026
10. Personnel Out-of-State Business Travel Report for February 2026
11. Report of the Community Equity, Health, and Justice Committee Meeting of March 11, 2026
12. Report of the Policy, Grants, and Technology Committee Meeting of March 18, 2026
13. Report of the Finance and Administration Committee Meeting of March 18, 2026

Public Comments

Public comments were given by Sejal Babaria, Community Advisory Council member.

Board Comments

None.

Board Action

Director González made a motion, seconded by Director Young, to approve Consent Calendar Items 7 through 13, inclusive; and the motion **carried** by the following vote of the Board:

- AYES: Adams, Barnacle, Brown, Carlson, Gallagher, Gioia, González, Haubert, Hopkins, Jue, Medina, Mueller, Quinto, Salinas, Sell, Tam, Veenker, Young.
- ABSTAIN: None.
- NOES: None.
- ABSENT: Abe-Koga, Colbert, Corzo, Lee, Mahmood, Walton.

**INFORMATIONAL ITEM**

**14. COMMUNITY ADVISORY COUNCIL'S (CAC) COMPLIANCE AND ENFORCEMENT RECOMMENDATIONS**

The Board of Directors discussed seven recommendations from the Air District’s Community Advisory Council designed to improve coordination, documentation, and communication in compliance and enforcement efforts to increase efficiency and improve emission reduction outcomes. Ther Board considered providing direction to Air District staff regarding the recommendations. The Community Equity, Health, and Justice Committee discussed this item at its meeting on March 11, 2026, and recommended it to the Board for discussion.

Community Advisory Council Member Ken Szutu, and Co-Chair, Patrick Messac, gave the presentation *Community Advisory Council's Compliance and Enforcement Recommendations*, including: outline; Crown Hill Materials: community experience; why a case study; case study resources; community perspective: complaint report; complaints without consequences; Recommendation #1 (Customer-Centered Complaint Process); enforcement gap: rules vs results; Recommendation #2 (Enforceable Rules); Recommendation #3 (Modernize Evidence Collection); Recommendation #4 (Transparent Permitting); impact over intention; Recommendation #5 (Protective Permitting Safeguards); Recommendation #6 (Strengthen Learning through Case Studies); beyond Crown Hill Materials: continuous improvement; Recommendation #7 (Top Community Concerns Framework); and recommendations in review.

Public Comments

Public comments were given by Ashia Ajani, Sierra Club; Kathy Kerridge, Benicia resident; Jan Warren, Interfaith Climate Action Network of Contra Costa County; Cecilia Cunningham,

Oakland resident; Marina Munoz, Oakland resident; and Arieann Harrison, Marie Harrison Community Foundation.

Board Comments

The Board and Air District staff discussed the desire for the identification of additional contributing factors to air pollution in unhealthy neighborhoods; how to ensure that case studies will be selected in an unbiased manner; whether the Air District has the authority or flexibility to decide whether to charge a fine, how much to charge, or whether to waive it; the desire to see Artificial Intelligence and image technology be utilized by the Air District; whether video evidence (owned by the public) may be used as proof of air pollution violations at permitted facilities; and the perception that air pollution complaints continue to be received by the Air District, but limited enforcement occurs.

Board Action

Vice Chair Veenker made a motion, seconded by Director Gioia, to direct Air District staff to review and analyze the Community Advisory Council’s seven Compliance and Enforcement recommendations and evaluate how they align with ongoing policy, assessment, and implementation efforts. To carry this out, staff should summarize how each recommendation is being addressed through actions currently underway, planned actions, or potential actions, and report back within 120 days to the Board with an update.

The motion **carried** by the following vote of the Board:

- AYES: Adams, Barnacle, Carlson, Corzo, Gallagher, Gioia, González, Hopkins, Jue, Medina, Mueller, Quinto, Salinas, Sell, Tam, Veenker, Young.
- ABSTAIN: None.
- NOES: None.
- ABSENT: Abe-Koga, Brown, Colbert, Haubert, Lee, Mahmood, Walton.

**ACTION ITEMS**

**15. FINAL DRAFT COMMUNITY EMISSIONS REDUCTION PLAN FOR EAST OAKLAND**

Manuel Oliva, Community Planning Manager, and Anna Lee, Environmental Justice Manager, gave the staff presentation *Final Draft Community Emissions Reduction Plan for East Oakland*, including: recommended action; East Oakland Assembly Bill (AB) 617 Community; East Oakland Community Steering Committee (CSC); Community Emissions Reduction Plan (CERP) development process; East Oakland community engagement; final Draft CERP goals; final Draft CERP strategy development; final Draft CERP focus areas; community concerns and action highlights; CERP public review; CSC approval and Community Equity, Health and Justice (CEHJ) Committee recommendation; California Environmental Quality Act (CEQA) compliance; recommended action; and CSC reflections.

Public Comments

Public comments were given by Jack Fleck, Keep Coal Out of Oakland Coalition; Bill Crotinger, Argent Materials, Inc.; Marina Munoz, Oakland resident; and Cecilia Cunningham, Oakland resident.

Board Comments

The Board and Air District staff discussed the request to reconcile misinformation about Argent Materials in the final report, as identified and requested by Argent Materials; the belief that industrial activity requires designated areas to operate effectively; whether the Air District interacts with Oakland International Airport, regarding sustainable aviation fuel practices; the suggestion that the Air District formally recognizes or expresses appreciation to permitted facilities that implement sound environmental practices and maintain compliance with regulatory requirements; appreciation for the focus on illegal dumping; and whether polluting industrial operations are typically located within designated AB 617 communities.

Board Action

Director Salinas made a motion, seconded by Director Tam, to **adopt** the Final Draft Community Emissions Reduction Plan for East Oakland, and **approve** the determination that adoption of the Community Emissions Reduction Plan is exempt from the California Environmental Quality Act; and the motion **carried** by the following vote of the Board:

- AYES: Adams, Barnacle, Carlson, Corzo, Gallagher, Gioia, González, Hopkins, Jue, Quinto, Salinas, Sell, Tam, Veenker, Young.
- ABSTAIN: None.
- NOES: None.
- ABSENT: Abe-Koga, Brown, Colbert, Haubert, Lee, Mahmood, Medina, Mueller, Walton.

16. **ANNUAL REPORT, BUDGET, AND DIRECTOR APPOINTMENTS OF THE BAY AREA CLEAN AIR FOUNDATION**

Due to the shortage of time, this presentation was waived by Chair Hopkins.

Public Comments

No requests received.

Board Comments

None.

Board Action

Director González made a motion, seconded by Director Tam, to (i) **approve** the adoption of the Bay Area Clean Air Foundation's 2027 Budget and (ii) **reappoint** Arsenio Mataka and

**appoint** Emi Wang to two-year terms as Directors of the Foundation; and the motion **carried** by the following vote of the Board:

AYES: Barnacle, Carlson, Corzo, Gallagher, Gioia, González, Hopkins, Jue, Quinto, Salinas, Sell, Tam, Veenker, Young.  
ABSTAIN: None.  
NOES: None.  
ABSENT: Abe-Koga, Adams, Brown, Colbert, Haubert, Lee, Mahmood, Medina, Mueller, Walton.

## 17. CONSIDERATION OF STATE LEGISLATION

Mr. Crockett announced that Director Adams informed him that she has a financial interest in the subject of AB 2313, one of the bills up for discussion in this item. He explained that Director Adams would need to recuse herself from any discussion or decision regarding AB 2313. Therefore, the Board needed to decide whether to segment Item 17 and consider AB 2313 separately from the other bills under consideration. When Chair Hopkins asked the Board, the consensus of the Board members present was to segment Item 17, allowing Director Adams to participate in the first part of the discussion that excluded AB 2313, and then recuse herself for the discussion and vote regarding AB 2313.

Alan Abbs, Legislative Officer, gave the staff presentation *Consideration of State Legislation*, including: abbreviations; recommended action; bill position recommendations – AB 1791 (Sanchez), AB 2752 (Ávila Farías), Senate Bill (SB) 299 (Cabaldon), SB 954 (Blakespear), SB 1392 (Cortese); additional bills for discussion – SB 1075 (Reyes); and recap of recommended action.

### Public Comments

Public comments were given by Heidi Taylor, Healthy Martinez.

### Board Comments

The Board and staff discussed whether items under AB 2752 (cost of compliance, potential cost to consumers, impacts on state and local tax revenue, refinery employment) are already factored into the Air District's socioeconomic analysis of a given rulemaking.

### Board Action

Director González made a motion, seconded by Director Tam, to **adopt** the following positions on the following bills:

- **Support** SB 299 (Cabaldon)
- **Support** SB 954 (Blakespear)
- **Oppose** AB 1791 (Sanchez)
- **Oppose** AB 2752 (Ávila Farías)
- **Oppose** SB 1392 (Cortese)

This motion included accepting the Air District staff recommendation for AB 2752 (Ávila Farías).

The motion carried by the following vote of the Board:

AYES: Adams, Barnacle, Carlson, Corzo, Gallagher, Gioia, González, Hopkins, Jue, Quinto, Salinas, Sell, Tam, Veenker, Young.  
ABSTAIN: None.  
NOES: None.  
ABSENT: Abe-Koga, Brown, Colbert, Haubert, Lee, Mahmood, Medina, Mueller, Walton.

Prior to any further discussion, Director Adams explained that she needed to recuse herself from any consideration or action on AB 2313 (Berman), which concerns a potential requirement for gas corporations to provide customers with monetary incentives to opt for gas distribution service line replacement alternatives, due to a financial interest in the matter because she receives income in the form of a salary for her position in Human Resources as the Director of Co-worker Inclusion and Belonging at Pacific Gas & Electric, a gas corporation that could become subject to this legislation.

Chair Hopkins noted for the record that Director Adams recused herself and left the meeting space.

The Board then turned to AB 2313 (Berman). Chair Hopkins waived the presentation by Mr. Abbs on this bill. Vice-Chair Veenker then made a motion, seconded by Director Carlson, to adopt the following position on the following bill:

- **Support** AB 2313 (Berman)

The motion carried by the following vote of the Board:

AYES: Barnacle, Carlson, Corzo, Gallagher, Gioia, González, Hopkins, Jue, Quinto, Salinas, Sell, Tam, Veenker, Young.  
ABSTAIN: None.  
NOES: None.  
ABSENT: Abe-Koga, Adams, Brown, Colbert, Haubert, Lee, Mahmood, Medina, Mueller, Walton.

### **INFORMATIONAL ITEM**

NOTED PRESENT: Following her recusal from Item 17, Director Adams returned to the Board Room.

### **18. UPDATE ON BAY AREA REGIONAL CLIMATE ACTION PLAN**

Due to the shortage of time, this presentation was waived by Chair Hopkins.

Public Comments

No requests received.

Board Comments

The Board and Air District staff discussed the Board's appreciation for staff's dedication to this multi-agency climate planning effort.

Board Action

No action taken.

**OTHER BUSINESS**

**19. PUBLIC COMMENT ON NON-AGENDA MATTERS**

Public comments were given by Jennifer Cohen, Pacific Merchant Shipping Association; Jack Fleck, Keep Coal Out of Oakland Coalition; Aaron Reaven, Keep Coal Out of Oakland Coalition; Jan Warren, Interfaith Climate Action Network of Contra Costa County; and Todd Osterberg, Chevron.

**20. BOARD MEMBER COMMENTS**

None.

**21. REPORT OF THE EXECUTIVE OFFICER / Air Pollution Control Officer (APCO)**

Dr. Philip M. Fine, Executive Officer / APCO, made the following announcements:

- The Bay Area Air District has opened the grant application period for the People's Air Grant Program, a funding opportunity designed to support local stakeholders working to improve air quality and public health in communities disproportionately burdened by air pollution. The grant application period opens March 12 and will remain open through May 29, 2026. The People's Air Grant Program invests directly in community-led efforts, providing the resources and support needed to turn local knowledge into real air quality improvements and stronger, more effective partnerships across the Bay Area. To support prospective applicants, the Air District will host two webinars: Tuesday, March 24 (Informational webinar) and Thursday, April 9 (Application preparation webinar). Community-based organizations, local nonprofit organizations, public agencies and California Native American Tribes serving environmental justice communities within the Bay Area are encouraged to apply. Application guidelines and additional information about the People's Air Grant Program are available at [www.baaqmd.gov/peoplesairgrant](http://www.baaqmd.gov/peoplesairgrant). Questions regarding the application process may be directed to [Peoplesairgrant@baaqmd.gov](mailto:Peoplesairgrant@baaqmd.gov).
- On March 19, 2026, the Air District's Community Advisory Council elected the following three Co-Chairs to lead the Council for a two-year term: William Goodwin, Patrick Messac, and LaTasha Washington.

22. **CHAIRPERSON'S REPORT**

None.

23. **TIME AND PLACE OF NEXT MEETING**

Wednesday, April 29, 2026, at 10:00 a.m. The meeting will be held in-person at the Bay Area Metro Center and at satellite locations as may be specified on the meeting agenda using a remote teleconferencing link. Members of the Board of Directors and the public may attend at any of those in-person locations, and members of the public may also attend virtually via webcast.

24. **ADJOURNMENT**

The meeting was adjourned at 2:27 p.m.

Marcy Hiratzka  
Clerk of the Boards

**BAY AREA AIR DISTRICT**  
Memorandum

To: Chairperson Lynda Hopkins and Members  
of the Board of Directors

From: Philip M. Fine  
Executive Officer/APCO

Date: May 6, 2026

Re: Board Communications Received from April 1, 2026, through May 5, 2026

RECOMMENDED ACTION

None; informational item only, no action is requested at this time.

BACKGROUND

None.

DISCUSSION

Copies of communications directed to the Board of Directors received by the Air District from April 1, 2026, through May 5, 2026, if any, will be distributed to the Board Members by way of email.

BUDGET CONSIDERATION/FINANCIAL IMPACT

None.

Respectfully submitted,

Philip M. Fine  
Executive Officer/APCO

Prepared by: Marjorie Villanueva  
Reviewed by: Vanessa Johnson

ATTACHMENT(S):

None

**BAY AREA AIR DISTRICT**  
Memorandum

To: Chairperson Lynda Hopkins and Members  
of the Board of Directors

From: Philip M. Fine  
Executive Officer/APCO

Date: May 6, 2026

Re: Notices of Violations Issued and Settlements in Excess of \$10,000 in the  
Month of March 2026

RECOMMENDED ACTION

None; informational item only, no action is requested at this time.

BACKGROUND

None.

DISCUSSION

In accordance with Resolution No. 2012-08, attached to this Memorandum is a listing of all Notices of Violations issued, and all settlements for amounts in excess of \$10,000 during the calendar months prior to this report.

BUDGET CONSIDERATION/FINANCIAL IMPACT

The penalties collected are recorded in the Air District's General Fund. A portion of the penalty funds may be expended in accordance with the Community Benefits Penalty Funds Policy adopted by the Board of Directors on May 1, 2024.

Respectfully submitted,

Philip M. Fine  
Executive Officer/APCO

Prepared by: Alexander G. Crockett

ATTACHMENT(S):

1. Notices of Violations Issued and Settlements in Excess of \$10,000 - March 2026

**NOTICES OF VIOLATIONS ISSUED**

The following Notice(s) of Violation(s) were issued in March 2026:

| <b>Alameda</b>            |               |             |              |                      |                   |  |
|---------------------------|---------------|-------------|--------------|----------------------|-------------------|--|
| <b>Site Name</b>          | <b>Site #</b> | <b>City</b> | <b>NOV #</b> | <b>Issuance Date</b> | <b>Regulation</b> | <b>Comment</b>                                     |
| 98th Gas and Mart         | D1140         | Oakland     | A64976A      | 3/18/26              | 8-7-408           | Gasoline Dispensing Facility Violation             |
| Blu Cal                   | S786508       | Oakland     | A64940A      | 3/10/26              | 11-2-401.3        | Asbestos Violation                                 |
| dB Control                | S786277       | Fremont     | A64275A      | 3/4/26               | 2-1-301           | No Authority to Construct and No Permit to Operate |
| dB Control                | S786277       | Fremont     | A64275B      | 3/4/26               | 2-1-302           | No Authority to Construct and No Permit to Operate |
| JS Company                | S786950       | Emeryville  | A63632A      | 3/17/26              | 11-2-401.5        | Asbestos Violation                                 |
| JS Company                | S786950       | Emeryville  | A63632B      | 3/17/26              | 11-2-303.8        | Asbestos Violation                                 |
| Marina Food Market        | C8315         | San Leandro | A64598A      | 3/18/26              | 8-7-301.5         | Gasoline Dispensing Facility Violation             |
| Marina Food Market        | C8315         | San Leandro | A64598B      | 3/18/26              | 8-7-302.3         | Gasoline Dispensing Facility Violation             |
| Monument Gas              | C0743         | San Leandro | A64597A      | 3/11/26              | 8-7-408           | Gasoline Dispensing Facility Violation             |
| Northwood Design Partners | E1810         | Union City  | A65053A      | 3/23/26              | 2-1-307           | Permit Requirement/Condition Violation             |
| Tesla, Inc.               | A1438         | Fremont     | A64276A      | 3/10/26              | 2-6-307           | Title V Requirement/Permit Condition Violation     |
| Tesla, Inc.               | A1438         | Fremont     | A64277A      | 3/10/26              | 2-6-307           | Title V Requirement/Permit Condition Violation     |
| TY Auto Body LLC          | B2650         | Oakland     | A61948A      | 3/3/26               | 2-1-302           | No Permit to Operate                               |
| Vasco Road Landfill       | A5095         | Livermore   | A63482A      | 3/3/26               | 2-6-307           | Title V Requirement/Permit Condition Violation     |

| <b>Contra Costa</b>                          |               |             |              |                      |                   |  |
|--|---------------|-------------|--------------|----------------------|-------------------|--|
| <b>Site Name</b>                             | <b>Site #</b> | <b>City</b> | <b>NOV #</b> | <b>Issuance Date</b> | <b>Regulation</b> | <b>Comment</b>   |
| Branagh Development                          | S787589       | Lafayette   | A63633A      | 3/26/26              | 11-2-401.5        | Asbestos Violation                                     |
| Chevron Products Company                     | A0010         | Richmond    | A64723A      | 3/3/26               | 2-6-307           | Title V Requirement/Permit Condition Violation         |
| Martinez Refining Company LLC                | A0011         | Martinez    | A65979A      | 3/3/26               | 9-1-307           | SO2 Emissions Violation                                |
| Martinez Refining Company LLC                | A0011         | Martinez    | A65980A      | 3/3/26               | 9-1-307           | SO2 Emissions Violation                                |
| Martinez Refining Company LLC                | A0011         | Martinez    | A65981A      | 3/3/26               | 10                | Code of Federal Regulation Violation                   |
| Martinez Refining Company LLC                | A0011         | Martinez    | A65982A      | 3/3/26               | 10                | Code of Federal Regulation Violation                   |
| Martinez Refining Company LLC                | A0011         | Martinez    | A65983A      | 3/3/26               | 9-1-307           | SO2 Emissions Violation                                |
| Martinez Refining Company LLC                | A0011         | Martinez    | A65984A      | 3/3/26               | 9-1-307           | SO2 Emissions Violation                                |
| Martinez Refining Company LLC                | A0011         | Martinez    | A65985A      | 3/3/26               | 10                | Code of Federal Regulation Violation                   |
| Martinez Refining Company LLC                | A0011         | Martinez    | A65986A      | 3/3/26               | 9-1-307           | SO2 Emissions Limit                                    |
| Martinez Refining Company LLC                | A0011         | Martinez    | A65986B      | 3/3/26               | 10                | Code of Federal Regulation Violation                   |
| Phillips 66 Company - San Francisco Refinery | A0016         | Rodeo       | A63001A      | 3/10/26              | 8-8-315           | Wastewater Collection and Separation Systems Violation |
| Stroud Development                           | S784448       | Lafayette   | A63631A      | 3/24/26              | 11-2-401.5        | Asbestos Violation                                     |

| <b>Marin</b>                    |               |             |              |                      |                   |  |
|---------------------------------|---------------|-------------|--------------|----------------------|-------------------|--|
| <b>Site Name</b>                | <b>Site #</b> | <b>City</b> | <b>NOV #</b> | <b>Issuance Date</b> | <b>Regulation</b> | <b>Comment</b>                         |
| Best Buy Company, Inc           | B8058         | San Rafael  | A64524A      | 3/13/26              | 2-1-302           | No Permit to Operate                   |
| Clipper Yacht Company, LLC      | C6257         | Sausalito   | A64993A      | 3/12/26              | 8-7-408           | Gasoline Dispensing Facility Violation |
| Huston General Contracting Inc. | S786533       | San Rafael  | A64925A      | 3/2/26               | 11-2-401.3        | Asbestos Violation                     |
| Huston General Contracting Inc. | S786533       | San Rafael  | A64925B      | 3/2/26               | 11-2-303.8        | Asbestos Violation                     |

| <b>Napa</b>              |               |             |              |                      |                   |                            |
|--------------------------|---------------|-------------|--------------|----------------------|-------------------|----------------------------|
| <b>Site Name</b>         | <b>Site #</b> | <b>City</b> | <b>NOV #</b> | <b>Issuance Date</b> | <b>Regulation</b> | <b>Comment</b>             |
| Four Seasons Napa Valley | S705668       | Calistoga   | A63557A      | 3/4/26               | 9-7-506           | Boiler Emissions Violation |
| Four Seasons Napa Valley | S705668       | Calistoga   | A63558A      | 3/4/26               | 9-7-506           | Boiler Emissions Violation |

| <b>San Francisco</b>            |               |               |              |                      |                   |  |
|---------------------------------|---------------|---------------|--------------|----------------------|-------------------|--|
| <b>Site Name</b>                | <b>Site #</b> | <b>City</b>   | <b>NOV #</b> | <b>Issuance Date</b> | <b>Regulation</b> | <b>Comment</b>                         |
| Amazon Auto Body                | E0183         | San Francisco | A64034A      | 3/3/26               | 2-1-302           | No Permit to Operate                   |
| Asana, Inc.                     | B8785         | San Francisco | A64036A      | 3/19/26              | 2-1-302           | No Permit to Operate                   |
| City Ventures Construction Inc. | S787590       | San Francisco | A63634A      | 3/30/26              | 11-2-401.5        | Asbestos Violation                     |
| U.S. Coast Guard                | C8908         | San Francisco | A64990A      | 3/4/26               | 2-1-307           | Permit Requirement/Condition Violation |
| U.S. Coast Guard                | C8908         | San Francisco | A64990B      | 3/4/26               | 8-7-408           | Gasoline Dispensing Facility Violation |

| <b>San Mateo</b>          |               |              |              |                      |                   |  |
|---------------------------|---------------|--------------|--------------|----------------------|-------------------|--|
| <b>Site Name</b>          | <b>Site #</b> | <b>City</b>  | <b>NOV #</b> | <b>Issuance Date</b> | <b>Regulation</b> | <b>Comment</b>                         |
| 10151 International       | S786648       | San Mateo    | A66179A      | 3/11/26              | 8-7-301.6         | Gasoline Dispensing Facility Violation |
| 10151 International       | S786648       | San Mateo    | A66179B      | 3/11/26              | 8-7-301.5         | Gasoline Dispensing Facility Violation |
| 10151 International       | S786648       | San Mateo    | A66179C      | 3/11/26              | 8-7-302.3         | Gasoline Dispensing Facility Violation |
| BP3-SF7 2001 JS Owner LLC | B3221         | Daly City    | A65143A      | 3/17/26              | 2-1-307           | Permit Requirement/Condition Violation |
| Chevron Bayshore          | D0024         | Daly City    | A63679A      | 3/10/26              | 8-7-408           | Gasoline Dispensing Facility Violation |
| Marin Properties, LLC     | S786747       | Redwood City | A64992A      | 3/13/26              | 8-7-408           | Gasoline Dispensing Facility Violation |

| <b>Santa Clara</b>                         |               |               |              |                      |                   |  |
|--|---------------|---------------|--------------|----------------------|-------------------|--|
| <b>Site Name</b>                           | <b>Site #</b> | <b>City</b>   | <b>NOV #</b> | <b>Issuance Date</b> | <b>Regulation</b> | <b>Comment</b>                                 |
| ARCO Facility #07037                       | C4102         | San Jose      | A66178A      | 3/4/26               | 8-7-308           | Gasoline Dispensing Facility Violation         |
| City of Mountain View (Shoreline Landfill) | A2740         | Mountain View | A65556A      | 3/4/26               | 2-6-307           | Title V Requirement/Permit Condition Violation |
| CT Senter Road Station                     | C9886         | San Jose      | A66180A      | 3/17/26              | 8-7-301.13        | Gasoline Dispensing Facility Violation         |
| Great America Gas & Auto Care              | C7225         | Santa Clara   | A59437A      | 3/16/26              | 2-1-302           | No Permit to Operate                           |
| Great America Gas & Auto Care              | C7225         | Santa Clara   | A59437B      | 3/16/26              | 2-1-307           | Permit Requirement/Condition Violation         |
| Great America Gas & Auto Care              | C7225         | Santa Clara   | A59437C      | 3/16/26              | 8-7-503           | Gasoline Dispensing Facility Violation         |
| Metcalf Energy Center                      | B2183         | Coyote        | A65412A      | 3/3/26               | 2-6-307           | Title V Requirement/Permit Condition Violation |

|   |         |             |         |         |            |  |
|---|---------|-------------|---------|---------|------------|--|
| Speed Construction and Development Inc. | S786546 | San Jose    | A64926A | 3/4/26  | 11-2-401.3 | Asbestos Violation                                 |
| Speed Construction and Development Inc. | S786546 | San Jose    | A64926B | 3/4/26  | 11-2-303.3 | Asbestos Violation                                 |
| Speed Construction and Development Inc. | S786546 | San Jose    | A64926C | 3/4/26  | 11-2-304   | Asbestos Violation                                 |
| Stevens Creek Union                     | C4436   | Santa Clara | A59436A | 3/16/26 | 2-1-301    | No Authority to Construct and No Permit to Operate |
| The Home Depot                          | B7742   | Gilroy      | A65413A | 3/25/26 | 2-1-302    | No Authority to Construct and No Permit to Operate |
| Tosco - Unocal #4848                    | C9657   | Sunnyvale   | A59434A | 3/5/26  | 8-7-302.3  | Gasoline Dispensing Facility Violation             |
| Vander-Bend Manufacturing Inc.          | E3467   | San Jose    | A65531A | 3/19/26 | 2-1-307    | Permit Requirement/Condition Violation             |

| <b>Solano</b>                        |               |             |              |                      |                   |                                      |
|--------------------------------------|---------------|-------------|--------------|----------------------|-------------------|--------------------------------------|
| <b>Site Name</b>                     | <b>Site #</b> | <b>City</b> | <b>NOV #</b> | <b>Issuance Date</b> | <b>Regulation</b> | <b>Comment</b>                       |
| Blucor Demolition                    | S787036       | Fairfield   | A59438A      | 3/18/26              | 11-2-401.5        | Asbestos Violation                   |
| Valero Refining Company - California | B2626         | Benicia     | A64499A      | 3/17/26              | 10                | Code of Federal Regulation Violation |

| <b>Sonoma</b>               |               |             |              |                      |                   |  |
|-----------------------------|---------------|-------------|--------------|----------------------|-------------------|--|
| <b>Site Name</b>            | <b>Site #</b> | <b>City</b> | <b>NOV #</b> | <b>Issuance Date</b> | <b>Regulation</b> | <b>Comment</b>                                 |
| Lindsey Strain              | S786906       | Petaluma    | A64525A      | 3/16/26              | 5-301             | Open Burn Violation                            |
| Republic Services of Sonoma | A2254         | Petaluma    | A64526A      | 3/23/26              | 2-6-307           | Title V Requirement/Permit Condition Violation |

|   |         |            |         |         |            |  |
|---|---------|------------|---------|---------|------------|--|
| County, Inc.                              |         |            |         |         |            |  |
| Republic Services of Sonoma County, Inc.  | A2254   | Petaluma   | A64526B | 3/23/26 | 8-34-301.1 | Landfill Violation                                 |
| Republic Services of Sonoma County, Inc.  | A2254   | Petaluma   | A64526C | 3/23/26 | 10         | Code of Federal Regulation Violation               |
| Santa Rosa Water - Laguna Treatment Plant | A1403   | Santa Rosa | A64334A | 3/12/26 | 2-6-307    | Title V Requirement/Permit Condition Violation     |
| Stocklin Iron Inc.                        | B6173   | Santa Rosa | A64333A | 3/11/26 | 2-1-302    | No Permit to Operate                               |
| Whispering Pines Pet Cemetery             | S786584 | Sebastopol | A64332A | 3/10/26 | 2-1-301    | No Authority to Construct and No Permit to Operate |
| Whispering Pines Pet Cemetery             | S786584 | Sebastopol | A64332B | 3/10/26 | 2-1-302    | No Authority to Construct and No Permit to Operate |

| <b>Company Address Outside of the Bay Area</b> |               |             |              |                      |                   |                             |
|--|---------------|-------------|--------------|----------------------|-------------------|-----------------------------|
| <b>Site Name</b>                               | <b>Site #</b> | <b>City</b> | <b>NOV #</b> | <b>Issuance Date</b> | <b>Regulation</b> | <b>Comment</b>              |
| Forever Shipping, S.A.                         | S786326       | Panama City | A65202A      | 3/5/26               | 6-1-301           | Visible Emissions Violation |

**SETTLEMENTS FOR \$10,000 OR MORE REACHED**

There were 3 settlements for \$10,000 or more completed in March 2026.

- 1) On March 19, 2026, the Air District reached a settlement with Central Concrete Supply Co. for \$50,000 regarding the allegations contained in the following 1 Notice of Violation:

| <b>NOV #</b> | <b>Issuance Date</b> | <b>Occurrence Date</b> | <b>Regulation</b> | <b>Comments from Enforcement</b>       |
|--------------|----------------------|------------------------|-------------------|--|
| A62888A      | 2/20/24              | 3/1/23                 | 2-1-307           | Permit Requirement/Condition Violation |

- 2) On March 23, 2026, the Air District reached a settlement with City and County of San Francisco, through San Francisco Sheriff's Office for \$30,450, regarding the allegations contained in the following 1 Notice of Violation:

| <b>NOV #</b> | <b>Issuance Date</b> | <b>Occurrence Date</b> | <b>Regulation</b> | <b>Comments from Enforcement</b> |
|--------------|----------------------|------------------------|-------------------|----------------------------------|
| A60970A      | 7/9/24               | 5/21/24                | 1-301             | Public Nuisance Violation        |

3) On March 27, 2026, the Air District reached a settlement with Anheuser-Busch, LLC for \$2,300,000, regarding the allegations contained in the following 5 Notices of Violations:

| <b>NOV #</b> | <b>Issuance Date</b> | <b>Occurrence Date</b> | <b>Regulation</b> | <b>Comments from Enforcement</b>                   |
|--------------|----------------------|------------------------|-------------------|--|
| A61178A      | 9/28/22              | 7/18/20                | 2-6-307           | Title V Requirement/Permit Condition               |
| A61179A      | 9/28/22              | 7/18/20                | 2-1-320           | Misrepresentation in Permit Application            |
| A61180A      | 9/28/22              | 7/18/20                | 2-1-301           | No Authority to Construct and No Permit to Operate |
| A61180B      | 9/28/22              | 7/18/20                | 2-1-302           | No Authority to Construct and No Permit to Operate |
| A61181A      | 9/28/22              | 7/18/20                | 2-1-301           | No Authority to Construct and No Permit to Operate |
| A61181B      | 9/28/22              | 7/18/20                | 2-1-302           | No Authority to Construct and No Permit to Operate |
| A63609A      | 5/5/25               | 1/1/25                 | 1-522             | Continuous Emissions Monitor Violation             |

**BAY AREA AIR DISTRICT**  
Memorandum

To: Chairperson Lynda Hopkins and Members  
of the Board of Directors

From: Philip M. Fine  
Executive Officer/APCO

Date: May 6, 2026

Re: Personnel Out-of-State Business Travel Report for March 2026

RECOMMENDED ACTION

No action is requested at this time.

BACKGROUND

Section 1.1.3 of the Air District's Employee Travel and Business Expense Policy (Policy) requires notification to the Board of Directors of Air District personnel who have traveled on out-of-state business. The monthly out-of-state business travel report is presented at a regular Board meeting following travel completion.

DISCUSSION

In accordance with Section 1.1.3 of the Policy, the Board of Directors is hereby notified of Air District personnel who have traveled on out-of-state business. This report covers out-of-state business travel for the month of March 2026.

The following out-of-state business travel activities occurred during the reporting period:

Air & Waste Management Association Data Centers Insights and Innovations Specialty Conference, Herndon, Virginia, March 24-26, 2026 attendee:

- Kelly Crawford, Deputy Executive Officer of Engineering and Compliance

BUDGET CONSIDERATION/FINANCIAL IMPACT

All associated business travel-related costs are covered by the respective division's Fiscal Year Ending 2026 Budget.

Respectfully submitted,

Philip M. Fine  
Executive Officer/APCO

Prepared by: Michelle Hutson  
Reviewed by: Stephanie Osaze

ATTACHMENT(S):

None

**BAY AREA AIR DISTRICT**  
Memorandum

To: Chairperson Lynda Hopkins and Members  
of the Board of Directors

From: Hyacinth Hinojosa  
Deputy Executive Officer, Finance and Administration

Date: May 6, 2026

Re: Approval of an Amendment to the Employment Agreement for General  
Counsel

RECOMMENDED ACTION

Approve the attached amendment to the Employment Agreement for General Counsel increasing the salary by up to 5%.

BACKGROUND

Alexander G. Crockett has served in the position as General Counsel since May 23, 2022. During the May 6, 2026, closed session of the Air District's Board of Directors, the Board will conduct the annual employment performance review for General Counsel.

DISCUSSION

The Board will consider amending the employment contract for General Counsel by providing a merit increase in salary consistent with General Counsel's employment agreement. The proposed amendment is included as Attachment 1.

BUDGET CONSIDERATION/FINANCIAL IMPACT

This salary is included in the proposed Fiscal Year 2026 and 2027 budgets under the Legal Division.

Respectfully submitted,

Hyacinth Hinojosa  
Deputy Executive Officer, Finance and Administration

Prepared by: Hyacinth Hinojosa

ATTACHMENT(S):

1. Draft\_Crockett Amended Employment Agreement No 5. District Counsel 2026-05-06
2. Crockett Amended Employment Agreement No 4. District Counsel 2025-06-04
3. Crockett Amended Employment Agreement No 3. District Counsel 2024-04-02
4. Crockett Amended Employment Agreement No 2. District Counsel 2024-06-05
5. Crockett Amended Employment Agreement No 1. District Counsel 2023-06-11
6. Crockett Employment Agreement District Counsel 2022-05-19

**AMENDMENT No. 5 TO EMPLOYMENT AGREEMENT**

General Counsel

This Amendment to Employment Agreement ("Agreement") is made and entered into on this 6th day of May 2026, by and between the **Bay Area Air Quality Management District** (the "District") and District Counsel **Alexander Crockett** ("Employee").

**WHEREAS**, the District and Employee are parties to an Agreement setting forth the terms and conditions of Employee's employment as General Counsel, dated May 19, 2022 ("Employment Agreement");

**WHEREAS**, Employee has been employed as General Counsel pursuant to the Employment Agreement since May 23, 2022;

**WHEREAS**, the Employment Agreement provides that Employee shall receive a one-year performance evaluation whereby the District Board will consider a salary increase of up to five percent (5%);

**WHEREAS**, the District Board conducted a performance evaluation-of Employee which included a closed session review on May 6, 2026; and

**WHEREAS**, the District desires to provide Employee a \_\_\_ percent (\_\_\_%) salary increase consistent with the favorable performance evaluation and the provisions of the Employment Agreement.

**NOW, THEREFORE**, the District and Employee agree to modify the Employment Agreement as follows:

1. Employee's annual base salary is increased \_\_\_ percent (\_\_\_%) from Employee's current yearly salary effective May 23, 2026. Section 4.a. of the Employment Agreement is hereby amended to reflect the new annual base salary of \$\_\_\_\_\_ effective May 23, 2026.
2. All other provisions of Employee's Employment Agreement remain in full force and effect without amendment.

**IN WITNESS WHEREOF**, the Parties have executed this Amendment to Employment Agreement which shall be effective upon the commencement date specified above.

**BAY AREA AIR QUALITY MANAGEMENT DISTRICT**

**EMPLOYEE**

\_\_\_\_\_  
Lynda Hopkins  
Board Chair

\_\_\_\_\_  
Alexander G. Crockett  
General Counsel

**AMENDMENT No. 4 TO EMPLOYMENT AGREEMENT**

General Counsel

This Amendment to Employment Agreement (“Agreement”) is made and entered into on this 4th day of June 2025, by and between the **Bay Area Air Quality Management District** (the “District”) and District Counsel **Alexander Crockett** (“Employee”).

**WHEREAS**, the District and Employee are parties to an Agreement setting forth the terms and conditions of Employee’s employment as General Counsel, dated May 19, 2022 (“Employment Agreement”);

**WHEREAS**, Employee has been employed as General Counsel pursuant to the Employment Agreement since May 23, 2022;

**WHEREAS**, the Employment Agreement provides that Employee shall receive a one-year performance evaluation whereby the District Board will consider a salary increase of up to five percent (5%);

**WHEREAS**, the District Board conducted a performance evaluation of Employee which included a closed session review on June 4, 2025; and

**WHEREAS**, the District desires to provide Employee a five percent (5%) salary increase consistent with the favorable performance evaluation and the provisions of the Employment Agreement.

**NOW, THEREFORE**, the District and Employee agree to modify the Employment Agreement as follows:

1. Employee’s annual base salary is increased five percent (5%) from Employee’s current yearly salary effective May 23, 2025. Section 4.a. of the Employment Agreement is hereby amended to reflect the new annual base salary of \$386,067.22 effective May 23, 2025.
2. All other provisions of Employee’s Employment Agreement remain in full force and effect without amendment.

**IN WITNESS WHEREOF**, the Parties have executed this Amendment to Employment Agreement which shall be effective upon the commencement date specified above.

**BAY AREA AIR QUALITY MANAGEMENT DISTRICT**

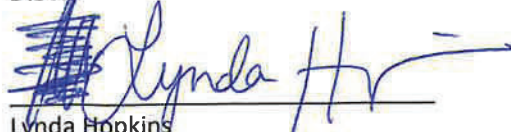
  
Lynda Hopkins  
Board Chair

**EMPLOYEE**

  
Alexander Crockett  
General Counsel

## AMENDMENT NO. 3 TO EMPLOYMENT AGREEMENT

General Counsel

This Amendment To Employment Agreement (“Amendment”) is made and entered into on this 2nd day of April, 2025, by and between the **Bay Area Air Quality Management District** (the “Air District”) and its General Counsel **Alexander Crockett** (“Employee”).

**WHEREAS**, the Air District and Employee are parties to an Agreement setting forth the terms and conditions of Employee’s employment as General Counsel (f/k/a District Counsel), dated May 19, 2022 (“Employment Agreement”);

**WHEREAS**, Employee has been employed as General Counsel (f/k/a District Counsel) pursuant to the Employment Agreement since May 23, 2022;

**WHEREAS**, the Employment Agreement provides that the Parties shall meet and confer four months prior to the expiration of the Employment Agreement regarding whether to extend the Employment Agreement, and if so on what terms;

**WHEREAS**, the Parties have met and conferred and mutually desire to extend the Employment Agreement for an additional three (3) years as provided for in this Amendment; and

**NOW, THEREFORE**, the Air District and Employee agree to amend the Employment Agreement as follows:

1. Paragraph 1 (Term) is amended to extend the term of the Employment Agreement for an additional three (3) years, such that Employee’s period of employment shall end on May 22, 2028, subject to the limitations of the Agreement.
2. Paragraph 7 (Termination and Severance), subparagraph (a), is similarly amended to extend the contractual term for an additional three (3) years, such that Employee’s employment as General Counsel will terminate on May 22, 2028, unless the parties agree to further extend the Employment Agreement on or before that date.
3. Paragraph 8 (Indemnification and Defense) is amended to add a new second paragraph, in addition to the existing paragraph that shall remain a part of the Employment Agreement, as follows:

“After termination of the Employment Agreement, should a need arise for Employee to respond to any subpoena or discovery, to provide testimony at deposition, trial, arbitration, or at an administrative hearing, or to otherwise perform services with respect to any matter relating to or arising out of Employee’s services rendered under the Employment Agreement, the Air District shall compensate Employee for time spent in doing so, including any required preparation time, at an hourly rate of two hundred fifty dollars (\$250) per hour. The Air District further agrees to reimburse Employee for all reasonable and necessary expenses incurred in connection with such work, subject to Employee providing proper documentation within sixty (60) days of the expense(s). Should Employee require separate legal representation as prescribed under California Government Code section 995.9, the Air District agrees to provide such representation.”

4. All references in the Employment Agreement to the position title "District Counsel" are amended to refer to the new position title "General Counsel."

All other provisions of the Employment Agreement remain in full force and effect without amendment.

**IN WITNESS WHEREOF**, the Parties have executed this Amendment to Employment Agreement, which shall be effective upon the commencement date specified above.

**BAY AREA AIR QUALITY MANAGEMENT  
DISTRICT**

  
Lynda Hopkins  
Board Chair

**EMPLOYEE**

  
Alexander Crockett  
General Counsel

**AMENDMENT No. 2 TO EMPLOYMENT AGREEMENT**

District Counsel

This Amendment to Employment Agreement (“Agreement”) is made and entered into on this 5th day of June, 2024, by and between the **Bay Area Air Quality Management District** (the “District”) and District Counsel **Alexander Crockett** (“Employee”).

**WHEREAS**, the District and Employee are parties to an Agreement setting forth the terms and conditions of Employee’s employment as General Counsel, dated May 19, 2022 (“Employment Agreement”);

**WHEREAS**, Employee has been employed as General Counsel pursuant to the Employment Agreement since May 23, 2022;

**WHEREAS**, the Employment Agreement provides that Employee shall receive a one-year performance evaluation whereby the District Board will consider a salary increase of up to five percent (5%);

**WHEREAS**, the District Board conducted a performance evaluation of Employee which included a closed session review on June 5, 2024; and

**WHEREAS**, the District desires to provide Employee a five percent (5%) salary increase consistent with the favorable performance evaluation and the provisions of the Employment Agreement.

**NOW, THEREFORE**, the District and Employee agree to modify the Employment Agreement as follows:

1. Employee’s annual base salary is increased five percent (5%) from Employee’s current yearly salary effective May 23, 2023. Section 4.a. of the Employment Agreement is hereby amended to reflect the new annual base salary of \$355,937.13 effective May 23, 2024.
2. All other provisions of Employee’s Employment Agreement remain in full force and effect without amendment.

**IN WITNESS WHEREOF**, the Parties have executed this Amendment to Employment Agreement which shall be effective upon the commencement date specified above.

**BAY AREA AIR QUALITY MANAGEMENT DISTRICT**



Davina Hurt  
Board Chair

**EMPLOYEE**



Alexander Crockett  
District Counsel

**AMENDMENT TO EMPLOYMENT AGREEMENT**

District Counsel

This Amendment To Employment Agreement (“Agreement”) is made and entered into on this 21<sup>st</sup> day of June, 2023, by and between the **Bay Area Air Quality Management District** (the “District”) and District Counsel **Alexander Crockett** (“Employee”).

**WHEREAS**, the District and Employee are parties to an Agreement setting forth the terms and conditions of Employee’s employment as District Counsel, dated May 19, 2022 (“Employment Agreement”);

**WHEREAS**, Employee has been employed as District Counsel pursuant to the Employment Agreement since May 23, 2022;

**WHEREAS**, the Employment Agreement provides that Employee shall receive a one-year performance evaluation whereby the District Board will consider a salary increase of up to five percent (5%);

**WHEREAS**, the District Board conducted a performance evaluation of Employee which included a closed session review on June 7, 2023; and

**WHEREAS**, the District desires to provide Employee a five percent (5%) salary increase consistent with the favorable performance evaluation and the provisions of the Employment Agreement.

**NOW, THEREFORE**, the District and Employee agree to modify the Employment Agreement as follows:

1. Employee’s annual base salary is increased five percent (5%) from Employee’s current yearly salary effective May 23, 2023. Section 4.a. of the Employment Agreement is hereby amended to reflect the new annual base salary of \$318,897.23 effective May 23, 2023.
2. All other provisions of Employee’s Employment Agreement remain in full force and effect without amendment.

**IN WITNESS WHEREOF**, the Parties have executed this Amendment to Employment Agreement which shall be effective upon the commencement date specified above.

**BAY AREA AIR QUALITY MANAGEMENT DISTRICT**

**EMPLOYEE**

DocuSigned by:

*John Bauters*

C7389B49E2C9458...  
JOHN J. BAUTERS

Board Chair

DocuSigned by:

*Alexander Crockett*

6DC7110552B5451...  
ALEXANDER CROCKETT

District Counsel

**EMPLOYMENT AGREEMENT**

District Counsel

This Employment Agreement (“Agreement”) is made and entered into on this 19th day of May 2022, by and between the **Bay Area Air Quality Management District** (the “District”) and **Alexander Crockett** (“Employee”) for services to be performed by Employee in the position of District Counsel. District and Employee are collectively hereinafter referred to as “Parties.”

**NOW, THEREFORE**, in consideration of the mutual promises and covenants set forth herein, the Parties agree as follows:

1. **Term.**

The District hereby employs Employee as District Counsel of the District and Employee hereby accepts employment for a period of three (3) years commencing on May 23, 2022, and ending on May 22, 2025, subject to the limitations of this Agreement.

2. **Duties.**

District Counsel shall manage the legal affairs of the District under the general direction and authority of the District Board of Directors (“Board”), or the Chief Executive Officer of the District, as the Board in its discretion may elect. Typical responsibilities include those detailed in the class specification of “Counsel” attached hereto as Exhibit A. Employee understands and agrees that these responsibilities are illustrative only and that the District may add, subtract, or change them in its discretion. Employee shall devote himself on a full-time basis to fulfillment of his responsibilities and shall devote such time as may be reasonably necessary for satisfactory performance of his obligations under this Agreement. Employee shall undertake no other professional employment during the term of this Agreement.

3. **Work Product/Attorney-Client Privilege**

Employee agrees that all files, notes, documents, data, specifications, correspondence, drawings, reports and other material prepared by or furnished to Employee in connection with his District employment shall be and remain the sole and exclusive property of the District. Employee acknowledges and agrees to maintain the District’s attorney-client confidences during and after the termination of this Agreement, in accord with the California Rules of Professional Conduct.



4. **Compensation and Benefits.**

a. **Salary**

For services rendered pursuant to this Agreement the District shall pay Employee an annual base salary of \$291,750. Said salary shall be paid on the dates and in the manner consistent with the payroll procedures of the District.

b. **Cost of Living Adjustments**

Employee shall receive an automatic cost of living adjustment on each July 1 during the term of employment equal to the California Consumer Price Index for Urban Wage

Initialed District  -  
Initialed Employee  -

Earners and Clerical Workers as calculated for the prior calendar year (“Annual Average”) by the Department of Industrial Relations for the San Francisco Bay Area.

**c. Fringe Benefits**

Except as otherwise provided in this Agreement, and except for an automobile allowance not to be included, Employee shall receive such employee benefits, including but not limited to pension, health insurance, and vacation benefits, as are payable to that class of District employees designated non-represented District Executive Management Staff. Employee shall be entitled to carry forward his accrued but unused District leave balances (sick leave, vacation, etc.) which existed on the effective date of this Agreement.

**d. Life Insurance**

In addition to any life insurance benefit provided under Paragraph 4(c) above, the District shall, during the term of this Agreement, provide Employee a portable \$500,000 (five hundred thousand dollar) term life insurance policy, if Employee demonstrates such good health insurability as the insurer may require.

**e. Income Tax Liabilities**

Employee shall be responsible for all income tax liability assessed under law on account of his Compensation under this Agreement

**5. Annual Goals.**



Employee shall develop an annual statement of goals and objectives and a progress report for the District and shall present such goals at a regularly called meeting of the Board to be selected each year by the Board Chair in coordination with District Counsel.

**6. Annual Performance Evaluation.**

Employee shall receive a one-year performance evaluation where the District will consider a salary increase up to five percent (5%). A two-year performance evaluation will be conducted by the District where the District will consider another salary increase up to five percent (5%). The District may, in its sole discretion, use any professional assistance in establishing standards for performance assessment. Nothing in this section shall be construed to require District to grant Employee any pay increases based on the performance standards, if any, mentioned above nor to limit in any manner the discretion of District to grant or not pay increases. Nor shall anything in this Agreement be interpreted to require District to evaluate Employee solely upon the performance standards, nor to limit the discretion of the District to evaluate Employee as it deems necessary in the sole discretion of the District.

**7. Termination and Severance.**

a. Employee’s tenure as District Counsel under this Agreement is limited to the contractual term of three (3) years and Employee’s employment as District Counsel will terminate on May 22, 2025 unless the parties agree to extend this Agreement on or before that date.

Initialed District  \_  
Initialed Employee  \_

The Parties agree to meet and confer four (4) months prior to the termination date to discuss whether to extend this Agreement, and if so on what terms.

- b. Moreover, due to the duties of the position and nature of the services provided by Employee to District, the Employee serves at-will at the pleasure of the Board, and nothing herein shall prevent, limit, or otherwise interfere with the right of the Board to terminate Employee with or without cause. Except where the termination is for cause, the District will provide written notice thirty (30) days prior to the termination date. The District may, at its option, relieve Employee of his duties with pay during the notice period. Employee shall have no right to a termination hearing. Employee shall have no "return rights" to any position previously held at the District and shall not be entitled to employment in any other District position upon termination of employment pursuant to this Agreement.
- c. If Employee's employment is terminated, either through expiration of the contractual term pursuant to section 7(a) or through earlier termination by the District pursuant to section 7(b), the District and Employee shall treat such termination as a retirement from District service for purposes of pension, health insurance, and other retirement benefits, unless Employee elects in writing not to have such termination treated as a retirement.
- d. Notwithstanding any other provision of this Agreement, and as required by Government Code Sections 3511.2 and 53260, if Employee is terminated by the District while the Employee is still willing and able to perform the duties of District Counsel, the District agrees to pay Employee a lump sum payment as follows: a cash settlement equal to Employee's monthly Base Salary, as adjusted, multiplied by the number of months left on the unexpired term of the Agreement, up to a maximum of twelve (12) months. Payment of this cash settlement shall not affect any retirement or other post-employment benefits employee may be entitled to under this Agreement or otherwise.
- e. Any severance payment made by the District pursuant to this section shall be contingent on Employee executing and delivering to the District a release in substantially the same form as that attached hereto as Exhibit B.
- f. Notwithstanding section 7(d) above, the District shall not be obligated to pay, and shall not pay any amounts to Employee if Employee is terminated because of:
  - i. the conviction of felony or misdemeanor or plea of nolo contendere to a crime,
  - ii. the conviction of any felony or misdemeanor involving moral turpitude,
  - iii. the willful or persistent material breach of duties or inattention to duties,
  - iv. a violation of statute or law constituting misconduct in office, or
  - v. willful misconduct.
- g. The District shall not be obligated to pay Employee any severance amount under this Agreement if Employee voluntarily retires or resigns in writing prior to termination, or if

employee is terminated at expiration of this agreement. In the event Employee voluntarily retires or resigns, Employee shall provide advance written notice to the District of at least thirty (30) calendar days.

h. This Agreement shall be immediately terminated upon Employee’s death or legal incapacity by operation of Labor Code section 2920.

8. **Indemnification and Defense.**

District shall indemnify, defend, and hold Employee harmless from and against all demands, claims, suits, actions, and legal proceedings brought against Employee and arising out of events within the scope of Employee’s employment and performance of professional duties as District Counsel, except to the extent that Employee’s actions are the result of gross negligence or willful misconduct. Employee shall cooperate in good faith with the District with respect to defense of such claims, demands, or legal actions.

9. **Abuse of Office.**

Any salary provided Employee during an investigation shall be fully reimbursed if the Employee is convicted of a crime involving an abuse of her office or position, as set forth in Government Code sections 53243 and 53243.4, resulting from the investigation. Any funds for the legal criminal defense of the Employee provided by the District shall be fully reimbursed to the District if the Employee is convicted of an abuse of her office or position, as set forth in Government Code sections 53243.1 and 53243.4. Further, regardless of the term of this Agreement, if this Agreement is terminated, any cash settlement or severance related to the termination that the Employee receives from the District shall be fully reimbursed to the District if the Employee is convicted of a crime involving an abuse of her office or position, as set forth in Government Code sections 53243.2 and 53243.4.

10. **Severability.**

If any term of this Agreement is finally held or determined to be illegal or void by a court having jurisdiction over the District and Employee, the remainder of this Agreement shall remain in full force and effect unless the term or terms held to be illegal or void are wholly inseparable from the remaining provisions of the Agreement.

11. **Governing Law.**



This Agreement shall be governed by the laws of the State of California.

12. **Counterparts.**

This Agreement may be executed in multiple counterparts, each of which shall constitute an original, and all of which taken together shall constitute one and the same instrument.

13. **Entire Agreement.**

This Agreement is the entire agreement between the parties regarding District’s employment of Employee and supersedes all prior oral or written understandings. This Agreement cannot be modified except by a written amendment signed by both Parties.

Initialed District  \_  
Initialed Employee  \_

**IN WITNESS WHEREOF**, the Parties have executed this Agreement which shall be effective upon the commencement date specified in Section 1 herein.

**BAY AREA AIR QUALITY MANAGEMENT DISTRICT**

DocuSigned by:

*John Banters* \_\_\_\_\_

C7389B49E2C9458...  
John Banters, Chairperson  
Board of Directors

**EMPLOYEE**

DocuSigned by:

*Alexander Crockett* \_\_\_\_\_

B5AE1A26FCA4453...  
ALEXANDER CROCKETT

**BAY AREA AIR DISTRICT**  
Memorandum

To: Chairperson Lynda Hopkins and Members  
of the Board of Directors

From: Hyacinth Hinojosa  
Deputy Executive Officer, Finance and Administration

Date: May 6, 2026

Re: Approval of an Amendment to the Employment Agreement for Executive  
Officer/APCO

RECOMMENDED ACTION

Approve an amendment to the Employment Agreement for the Executive Officer/Air Pollution Control Officer (APCO) to clarify that the District's contribution to the Executive Officer/APCO's 457(b) deferred compensation plan is indexed to the maximum allowable contribution set annually by the Internal Revenue Service (IRS), consistent with the Board's original intent at the time the Agreement was approved.

BACKGROUND

On December 3, 2025, the Board approved an Employment Agreement with the Executive Officer/Air Pollution Control Officer that included an Air District matching contribution to the Executive Officer/APCO's 457(b) deferred compensation account. At the time of approval, the Board's intent was to provide a matching contribution tied to the IRS-established maximum contribution limits, which are adjusted periodically for inflation.

Subsequently, it was identified that Section 4.F of the Employment Agreement reflected a fixed dollar amount rather than explicitly referencing the IRS maximum, which may intentionally limit the contribution in future years as federal limits change.

DISCUSSION

The proposed amendment clarifies — not expands — the benefit originally authorized by the Board by expressly linking the Air District's 457(b) contribution to the applicable IRS maximum contribution limits, including employee and allowable catch-up contributions. Beginning January 1, 2027, the Air District's contribution will be up to 50 percent of the maximum tax-deferred contribution permitted by the IRS for that calendar year, recognizing that such limits are adjusted over time for inflation.

This amendment aligns the written contract language with the Board's original intent and with standard deferred compensation practices that rely on annually indexed federal limits rather than static dollar amounts. The amendment does not establish a new benefit, increase the percentage match, or alter the structure of the contribution; it solely ensures that the contribution keeps pace with IRS adjustments as originally contemplated. The proposed amendment is included as Attachment 1.

BUDGET CONSIDERATION/FINANCIAL IMPACT

None. Salary and benefits are included in the Fiscal Year Ending 2026 and the proposed Fiscal Year 2027 budgets under Program 104.

Respectfully submitted,

Lynda Hopkins  
Board Chairperson

Prepared by: Hyacinth Hinojosa

ATTACHMENT(S):

1. Draft Amended No. 1 to APCO Employment Agreement

## AMENDMENT NO. 1 TO EMPLOYMENT AGREEMENT

Executive Officer and Air Pollution Control Officer

This Amendment to the Employment Agreement (“Amendment”) is made and entered into on this 6th day of May, 2026, by and between the **Bay Area Air Quality Management District** (the “Air District”) and its Executive Officer and Air Pollution Control Officer **Philip Fine** (“Employee”).

**WHEREAS**, the Air District and Employee are parties to an Agreement setting forth the terms and conditions of Employee’s employment as Executive Officer and Air Pollution Control Officer dated December 3, 2025 (“Employment Agreement”);

**WHEREAS**, the Employment Agreement provides that the Parties shall meet and confer four months prior to the expiration of the Employment Agreement regarding whether to extend the Employment Agreement, and if so on what terms;

**WHEREAS**, the Employment Agreement provides for a District match to Employee’s 457(b) Deferred Compensation account; and

**WHEREAS**, the Air District and Employee agree that Section 4.F inaccurately contained a fixed amount of the Air District’s matching contribution as the parties intent was to allow for a matching contribution that was subject to change in future years due to inflation adjustments;

**NOW, THEREFORE**, the Air District and Employee agree to amend the Employment Agreement as follows:

1. Paragraph 4.f (Term) is replaced as follows:

#### 4.f. Deferred Compensation

- 1 Beginning March 1, 2026, the District shall contribute into Employee’s 457(b) deferred compensation account for employee only and catch-up contributions as allowed by the Internal Revenue Service. The maximum is \$16,250 (sixteen thousand, two hundred and fifty dollars) in calendar year 2026.

2. Beginning January 1, 2027, the District shall contribute into Employee’s 457(b) deferred compensation account up to fifty percent (50%) of the maximum tax deferred contribution for employee only and catch-up contributions. This maximum is subject to change in future years due to inflation adjustments as set by the Internal Revenue Service.

3. The contributions shall be made on an annual basis or on a per pay period basis.

All other provisions of the Employment Agreement remain in full force and effect without amendment.

**IN WITNESS WHEREOF**, the Parties have executed this Amendment No. 1 to Employment Agreement, which shall be effective upon the commencement date specified above.

**BAY AREA AIR QUALITY MANAGEMENT  
DISTRICT**

**EMPLOYEE**

---

Lynda Hopkins  
Board Chair

---

Philip Fine  
Executive Officer and Air Pollution Control  
Officer

DRAFT

**BAY AREA AIR DISTRICT**  
Memorandum

To: Chairperson Lynda Hopkins and Members  
of the Board of Directors

From: Philip M. Fine  
Executive Officer/APCO

Date: May 6, 2026

Re: Authorization to Amend Contract with Acterra for Bayview Hunters  
Point/Southeast San Francisco Assembly Bill 617 Community Steering  
Committee Support

RECOMMENDED ACTION

Authorize the Executive Officer/APCO to amend the Air District's contract with Acterra to extend the contract term end date to September 30, 2027, and to increase the current contract amount by \$391,208, from \$199,000 to a total contract amount not to exceed \$590,208. The amendment will allow Acterra to continue providing meeting logistics support for the Bayview Hunters Point/Southeast San Francisco Assembly Bill 617 Community Steering Committee.

BACKGROUND

In February 2023, the California Air Resources Board voted to support the Air District to create a Community Emissions Reduction Plan (CERP) with community members in Bayview Hunters Point/Southeast San Francisco (BVHP/SESF). To guide this effort, the Air District and Community Co-Lead Partners, Bayview Hunters Point Community Advocates and Marie Harrison Community Foundation, established a Community Steering Committee (CSC) comprised of up to twenty-five (25) community members, including two elected Co-Chairs. The CSC has met monthly since January 2024, in Bayview Hunters Point, San Francisco, with in-person meetings open to the public.

The BVHP/SESF CSC has adopted the CERP Boundary, Vision and Principles and focus areas and is currently developing strategies and actions across six focus areas.

Acterra Contract No. 2025.171, executed in July 2025 for an amount not to exceed \$199,000, provides for logistical and administrative coordination services for the BVHP/SESF Assembly Bill (AB) 617 CSC. These services ensure the Air District meets state requirements for language access and accessibility needs and provide logistical support for the CSC process. Amendment 1 extended the ending date of the contract term to May 31, 2026 at no additional cost.

## DISCUSSION

Amendment 2 to Acterra's contract allows for the continuation of services to support the CSC through the CERP development process and implementation. Services include:

- Planning and preparation for all public CSC monthly meetings in coordination with the Air District, Co-Lead and CSC Co-Chairs
- Securing accessible, community-based meeting locations, including logistics and food
- Translation of public meeting materials and simultaneous interpretation, as needed
- Administration and disbursement of monthly CSC stipends and reimbursement of eligible childcare and transportation expenses associated with CSC monthly meetings Tracking jobs created for bi-annual reporting to California Air Resources Board (CARB)

## BUDGET CONSIDERATION/FINANCIAL IMPACT

Funding for this contract amendment is included in Fiscal Year Ending 2026 budget, Program 617.

Respectfully submitted,

Philip M. Fine  
Executive Officer/APCO

Prepared by: Yami Henry  
Reviewed by: Diana Ruiz

## ATTACHMENT(S):

1. Acterra Contract No. 2025.171
2. Acterra 2025.171 Amendment 1
3. Draft\_Acterra 2025.171 Amendment 2

**BAY AREA AIR QUALITY MANAGEMENT DISTRICT**

**PROFESSIONAL SERVICES CONTRACT**

**CONTRACT NO. 2025.171**

1. **PARTIES** – The parties to this Contract (“Contract”) are the Bay Area Air Quality Management District (“DISTRICT”) whose address is 375 Beale Street, Suite 600, San Francisco, CA 94105, and **Acterra** (“CONTRACTOR”) whose address is 3921 East Bayshore Road, Suite 210, Palo Alto, CA 94303.
  
2. **RECITALS**
  - A. DISTRICT is the local agency with primary responsibility for regulating stationary source air pollution in the Bay Area Air Quality Management District in the State of California. DISTRICT is authorized to enter into this Contract under California Health and Safety Code Section 40701. DISTRICT desires to contract with CONTRACTOR for services described in the Scope of Work, attached hereto as Attachment A and made a part hereof by this reference. DISTRICT is entering into this Contract based on CONTRACTOR’s stated qualifications to perform the services.
  - B. CONTRACTOR understands and recognizes that the Assembly Bill (AB) 617 Community Emissions Reduction Program (CERP) development process requires a partnership between DISTRICT, its contractors, and Community Steering Committee (CSC) members. CONTRACTOR agrees to collaboratively partner with DISTRICT to effectuate the objectives and requirements of AB 617.
  - C. All parties to this Contract have had the opportunity to have this contract reviewed by their attorney.
  
3. **PERFORMANCE REQUIREMENTS**
  - A. CONTRACTOR is authorized to do business in the State of California. CONTRACTOR attests that it is in good tax standing with federal and state tax authorities.
  - B. CONTRACTOR agrees to obtain any and all required licenses, permits, and all other appropriate legal authorizations from all applicable federal, state and local jurisdictions and to pay all applicable fees.
  - C. CONTRACTOR shall comply with all laws and regulations that apply to its performance under this Contract, including any requirements to disclose potential conflicts of interest under DISTRICT’s Conflict of Interest Code.
  - D. CONTRACTOR shall not engage in any performance of work during the term of this contract that is in direct or indirect conflict with duties and responsibilities set forth in the Scope of Work.
  - E. CONTRACTOR shall exercise the degree of skill and care customarily required by accepted professional practices and procedures.
  - F. CONTRACTOR agrees to complete a workplace training on preventing a hostile work environment (including illegal discrimination, harassment, and bullying). The training must either be provided by or approved by DISTRICT. Within sixty (60) days of execution of this Contract, CONTRACTOR must provide the DISTRICT a certificate of completion or other proof of completion of the training for each employee who will regularly work with DISTRICT staff

and/or Community Steering Committee members. If additional employees are hired or assigned to regularly work with DISTRICT staff and/or Community Steering Committee members after this Contract is executed, CONTRACTOR shall have 60 days from the date of each employee's hiring or assignment to provide that employee's certificate of completion or other proof of completion. CONTRACTOR shall send the certificates of completion or other proof of completion to HR\_Staff@baaqmd.gov.

- G. CONTRACTOR shall ensure that any subcontractors, employees and agents performing under this Contract comply with the performance standards set forth in paragraphs A-F above.
4. TERM – The term of this Contract is from the latter date of Contract execution to March 31, 2026, unless further extended by amendment of this Contract in writing and signed by both parties, or terminated earlier. CONTRACTOR shall not submit any invoice for services performed under this Contract until the Contract is fully executed.
5. TERMINATION
- A. The DISTRICT may terminate this Contract at any time, at will, and without specifying any reason, by notifying CONTRACTOR in writing. The notice of termination shall specify the effective date of termination, which shall be no less than thirty (30) calendar days from the date of delivery of the notice of termination, as set forth in section 10, below, and shall be delivered in accordance with the provisions of section 10 below. Immediately upon receipt of the notice of termination, CONTRACTOR shall cease all work under this Contract, except such work as is specified in the notice of termination. CONTRACTOR shall deliver a final invoice for all remaining work performed but not billed, including any work specified in the termination notice, on or before ten (10) business days following the effective date of termination.
  - B. Either party may terminate this Contract for breach by the other party.
    - i) Failure to perform any agreement or obligation contained in this Contract or failure to perform the services in a satisfactory manner shall constitute a breach of the Contract.
    - ii) The non-breaching party may terminate the Contract by delivery of a written notice of breach. The notice of breach shall specify the date of termination, which shall be no earlier than ten (10) business days from delivery of the notice of breach. In the alternative, at its sole discretion, the non-breaching party may require the breaching party to cure the breach. The notice of breach shall specify the nature of the breach and the date by which such breach must be cured.
    - iii) If CONTRACTOR fails to perform any obligation under this Contract, DISTRICT, at its sole discretion, may perform, or cause the performance of, the obligation itself. In that event, DISTRICT shall deduct the costs to perform such obligation and any other costs to cure the breach from the payment otherwise due to CONTRACTOR for work performed under this Contract. DISTRICT's performance hereunder shall not be deemed a waiver or release of any obligation of, or default by, CONTRACTOR under this Contract.
    - iv) The notice of breach shall be provided in accordance with the notice requirements set forth in section 10.
    - v) The non-breaching party reserves all rights under law and equity to enforce this Contract and recover any damages.

6. INSURANCE

- A. CONTRACTOR shall maintain the following insurance:
  - i) Workers' compensation and employers' liability insurance as required by California law or other applicable statutory requirements.
  - ii) Occurrence-based commercial general liability insurance or equivalent form with a limit of not less than one million dollars (\$1,000,000) each occurrence. Such insurance shall include DISTRICT and its officers, agents, and employees as additional insureds and shall be primary with respect to any insurance maintained by DISTRICT.
  - iii) Business automobile liability insurance or equivalent form with a limit of not less than one million dollars (\$1,000,000) each accident. Such insurance shall include coverage for owned, hired, and non-owned vehicles. If CONTRACTOR is a sole proprietor, CONTRACTOR may meet this insurance requirement with personal automobile liability insurance carrying a business use endorsement or by demonstrating to the satisfaction of DISTRICT that business use is covered under the CONTRACTOR's personal automobile liability insurance. A CONTRACTOR using only rental vehicles in performing work under this Contract may meet this insurance requirement by purchasing automobile liability insurance in the required coverage amount from the rental agency.
  - iv) Professional liability insurance with limits not less than one million dollars (\$1,000,000) each claim.
- B. All insurance shall be placed with insurers acceptable to DISTRICT.
- C. Prior to commencement of work under this Contract, CONTRACTOR shall furnish properly-executed certificates of insurance for all required insurance. Upon request by DISTRICT, CONTRACTOR shall provide a complete copy of any required insurance policy. CONTRACTOR shall notify DISTRICT in writing thirty (30) days prior to cancellation or modification of any required insurance policy. Any such modifications are subject to pre-approval by DISTRICT.
- D. If CONTRACTOR fails to maintain the required insurance coverage set forth above, DISTRICT reserves the right either to purchase such additional insurance and deduct the cost thereof from any payments owed to CONTRACTOR or to terminate this Contract for breach.

7. INDEMNIFICATION

- A. CONTRACTOR shall indemnify and hold DISTRICT, its officers, employees and agents harmless from and against any and all liability, loss, expense, including reasonable attorneys' fees, or claims for injury or damages arising out of the performance of this Contract, but only in proportion to and to the extent such liability, loss, expense, attorneys' fees, or claims for injury or damages are caused by or result from the negligent or intentional acts or omissions of CONTRACTOR, its officers, agents, or employees.
- B. DISTRICT shall indemnify and hold CONTRACTOR, its officers, employees and agents harmless from and against any and all liability, loss, expense, including reasonable attorneys' fee, or claims for injury or damages arising out of the performance of this Contract, but only in proportion to and to the extent such liability, loss, expense, attorneys' fees, or claims for injury or damages are caused by or result from the negligent or intentional acts or omissions of DISTRICT, its officers, agents, or employees.

8. PAYMENT

- A. DISTRICT shall pay CONTRACTOR for services in accordance with the terms set forth in the Cost Schedule, which is attached hereto as Attachment B and incorporated herein by this reference.
- B. CONTRACTOR shall submit invoice(s) to DISTRICT for services performed. Each invoice shall

specify the total cost of the services for which the invoice is submitted, shall reference tasks shown in the Scope of Work, the hours associated with same, or percentage completion thereof, and the amount of charge claimed, and, as appropriate, shall list any charges for equipment, material, supplies, travel, and subcontractors' services.

- C. DISTRICT's payment of invoices shall be subject to the following limitations and requirements:
    - i) Each invoice, including supporting documentation, shall be prepared in duplicate on CONTRACTOR's letterhead; shall list DISTRICT's contract number, the period covered by the invoice, and the CONTRACTOR's Social Security Number or Federal Employer Identification Number; and shall be submitted to: Bay Area Air Quality Management District, 375 Beale Street, Suite 600, San Francisco, CA 94105, Attn: Anna Lee
    - ii) DISTRICT shall not pay interest, fees, handling charges, or the cost of money on the Contract.
    - iii) DISTRICT shall pay CONTRACTOR within thirty (30) calendar days after approval by DISTRICT of an itemized invoice.
  - D. The total amount for which DISTRICT may be held liable for the performance of services specified in this Contract shall not exceed \$199,000.
9. DISPUTE RESOLUTION – A party that disputes a notice of breach must first seek mediation to resolve the dispute in accordance with the provisions set forth below.
- A. Upon receipt of a notice of breach of contract, the party may submit a demand for mediation to resolve whether or not a breach occurred. The party must state the basis of the dispute and deliver the demand within ten (10) business days of the date of receipt of the notice of breach.
  - B. The mediation shall take place at DISTRICT's office at 375 Beale Street, Suite 600, San Francisco, or at such other place as may be mutually agreed upon by the parties and the mediator.
  - C. The parties shall make good faith efforts to hold the mediation within thirty (30) days after receipt of the demand for mediation.
  - D. Each party shall bear its own mediation costs.
  - E. In the event the parties are unable to resolve the dispute, either party may file an action in a court of competent jurisdiction to enforce the Contract.
  - F. Maximum recovery under this section shall be limited to \$199,000. The mediation costs shall not reduce the maximum amount recoverable under this section.
10. NOTICES – All notices that are required under this Contract shall be provided in the manner set forth herein, unless specified otherwise. Notice to a party shall be delivered to the attention of the person listed below, or to such other person or persons as may hereafter be designated by that party in writing. Notice shall be in writing sent by e-mail, facsimile, or regular first class mail. In the case of e-mail and facsimile communications, valid notice shall be deemed to have been delivered upon sending, provided the sender obtained an electronic confirmation of delivery. E-mail and facsimile communications shall be deemed to have been received on the date of such transmission, provided such date was a business day and delivered prior to 4:00 p.m. pacific time. Otherwise, receipt of e-mail and facsimile communications shall be deemed to have occurred on the following business day. In the case of regular mail notice, notice shall be deemed to have been delivered on the mailing date and received five (5) business days after the date of mailing.

DISTRICT: Bay Area Air Quality Management District  
375 Beale Street, Suite 600  
San Francisco, CA 94105  
Attn: Anna Lee

CONTRACTOR: Acterra  
3921 East Bayshore Road, Suite 210  
Palo Alto, CA 94303  
Attn: Lourdes Arce

11. ADDITIONAL PROVISIONS – All attachment(s) to this Contract are expressly incorporated herein by this reference and made a part hereof as though fully set forth.

12. EMPLOYEES OF CONTRACTOR

- A. CONTRACTOR shall be responsible for the cost of regular pay to its employees, as well as cost of vacation leave, vacation replacements, sick leave, severance pay, and pay for legal holidays.
- B. CONTRACTOR, its officers, employees, agents, or representatives shall not be considered employees or agents of DISTRICT, nor shall CONTRACTOR, its officers, employees, agents, or representatives be entitled to or eligible to participate in any benefits, privileges, or plans given or extended by DISTRICT to its employees.
- C. CONTRACTOR shall assign those employees listed in the Cost Schedule to perform work under this Contract. CONTRACTOR shall not assign different employees to perform this work without the express written permission of DISTRICT, which DISTRICT will not unreasonably withhold.
- D. DISTRICT reserves the right to review the credentials to perform the work of any of CONTRACTOR's employees assigned herein and to disapprove CONTRACTOR's assignments. CONTRACTOR warrants that it will not employ any subcontractor(s) without prior written approval from DISTRICT.

13. CONFIDENTIALITY – In order to carry out the purposes of this Contract, CONTRACTOR may require access to certain of DISTRICT's confidential information (including trade secrets, inventions, confidential know-how, confidential business information, and other information that DISTRICT considers confidential) (collectively, "Confidential Information"). It is expressly understood and agreed that DISTRICT may designate in a conspicuous manner Confidential Information that CONTRACTOR obtains from DISTRICT, and CONTRACTOR agrees to:

- A. Observe complete confidentiality with respect to such information, including, without limitation, agreeing not to disclose or otherwise permit access to such information by any other person or entity in any manner whatsoever, except that such disclosure or access shall be permitted to employees of CONTRACTOR requiring access in fulfillment of the services provided under this Contract.
- B. Ensure that CONTRACTOR's officers, employees, agents, representatives, and independent contractors are informed of the confidential nature of such information, and to assure by agreement or otherwise, that they are prohibited from copying or revealing, for any purpose whatsoever, the contents of such information or any part thereof, or from taking any action otherwise prohibited under this section.
- C. Not use such information or any part thereof in the performance of services to others or for

the benefit of others in any form whatsoever, whether gratuitously or for valuable consideration, except as permitted under this Contract.

- D. Notify DISTRICT promptly and in writing of the circumstances surrounding any possession, use, or knowledge of such information, or any part thereof, by any person or entity other than those authorized by this section. Take, at CONTRACTOR's expense but at DISTRICT's option, and in any event under DISTRICT's control, any legal action necessary to prevent unauthorized use of such information by any third party or entity which has gained access to such information at least in part due to the fault of CONTRACTOR.
- E. Take any and all other actions necessary or desirable to assure such continued confidentiality and protection of such information during the term of this Contract and following expiration or termination of the Contract.
- F. Prevent access to such materials by a person or entity not authorized under this Contract.
- G. Establish specific procedures in order to fulfill the obligations of this section.

14. INTELLECTUAL PROPERTY RIGHTS – Title and full ownership rights to all intellectual property developed under this Contract shall at all times remain with DISTRICT, unless otherwise agreed to in writing.

15. PUBLICATION

- A. DISTRICT shall approve in writing any report or other document prepared by CONTRACTOR in connection with performance under this Contract prior to dissemination or publication of such report or document to a third party. DISTRICT may waive in writing its requirement for prior approval.
- B. Until approved by DISTRICT, any report or other document prepared by CONTRACTOR shall include on each page a conspicuous header, footer, or watermark stating "DRAFT – Not Reviewed or Approved by BAAQMD," unless DISTRICT has waived its requirement for prior approval pursuant to paragraph A of this section.
- C. Information, data, documents, or reports developed by CONTRACTOR for DISTRICT pursuant to this Contract shall be part of DISTRICT's public record, unless otherwise indicated. CONTRACTOR may use or publish, at its own expense, such information, provided DISTRICT approves use of such information in advance. The following acknowledgment of support and disclaimer must appear in each publication of materials, whether copyrighted or not, based upon or developed under this Contract:

"This report was prepared as a result of work sponsored, paid for, in whole or in part, by the Bay Area Air Quality Management District (District). The opinions, findings, conclusions, and recommendations are those of the author and do not necessarily represent the views of the District. The District, its officers, employees, contractors, and subcontractors make no warranty, expressed or implied, and assume no legal liability for the information in this report."

- D. CONTRACTOR shall inform its officers, employees, and subcontractors involved in the performance of this Contract of the restrictions contained herein and shall require compliance with this section.

16. AUDIT / INSPECTION OF RECORDS – If this Contract exceeds \$10,000, pursuant to California Government Code Section 8546.7, all records, documents, conditions and activities of

CONTRACTOR, and its subcontractors, related to the services provided hereunder, shall be subject to the examination and audit of the California State Auditor and other duly authorized agents of the State of California for a period of three (3) years after final payment under this Contract. CONTRACTOR hereby agrees to make such records available during normal business hours for inspection, audit, and reproduction by any duly authorized agents of the State of California or DISTRICT. CONTRACTOR further agrees to allow interviews of any of its employees who might reasonably have information related to such records by any duly authorized agents of the State of California or DISTRICT. All examinations and audits conducted under this section shall be strictly confined to those matters connected with the performance of this Contract, including, but not limited to, the costs of administering this Contract.

17. NON-DISCRIMINATION – In the performance of this Contract, CONTRACTOR shall not discriminate in its recruitment, hiring, promotion, demotion, and termination practices on the basis of race, religious creed, color, national origin, ancestry, sex, age, marital status, sexual orientation, medical condition, or physical or mental disability, and shall comply with the provisions of the California Fair Employment & Housing Act (Gov. Code, §§12900 et seq.), the Federal Civil Rights Act of 1964 (P.L. 88-352) and all amendments thereto, and all administrative rules and regulations issued pursuant to said Acts. CONTRACTOR shall also require each subcontractor performing work in connection with this Contract to comply with this section, and shall include in each contract with such subcontractor provisions to accomplish the requirements of this section.
18. PROPERTY AND SECURITY – Without limiting CONTRACTOR’S obligations with regard to security, CONTRACTOR shall comply with all the rules and regulations established by DISTRICT for access to and activity in and around DISTRICT’S premises.
19. ASSIGNMENT – No party shall assign, sell, license, or otherwise transfer any rights or obligations under this Contract to a third party without the prior written consent of the other party, and any attempt to do so shall be void upon inception.
20. WAIVER – No waiver of a breach, of failure of any condition, or of any right or remedy contained in or granted by the provisions of this Contract shall be effective unless it is in writing and signed by the party waiving the breach, failure, right, or remedy. No waiver of any breach, failure, right, or remedy shall be deemed a waiver of any other breach, whether or not similar, nor shall any waiver constitute a continuing waiver unless the writing so specifies. Further, the failure of a party to enforce performance by the other party of any term, covenant, or condition of this Contract, and the failure of a party to exercise any rights or remedies hereunder, shall not be deemed a waiver or relinquishment by that party to enforce future performance of any such terms, covenants, or conditions, or to exercise any future rights or remedies.
21. ATTORNEYS’ FEES – In the event any action is filed in connection with the enforcement or interpretation of this Contract, each party shall bear its own attorneys’ fees and costs.
22. FORCE MAJEURE – Neither DISTRICT nor CONTRACTOR shall be liable for or deemed to be in default for any delay or failure in performance under this Contract or interruption of services resulting, directly or indirectly, from acts of God, enemy or hostile governmental action, civil commotion, strikes, lockouts, labor disputes, fire or other casualty, judicial orders, governmental controls, regulations or restrictions, inability to obtain labor or materials or

reasonable substitutes for labor or materials necessary for performance of the services, or other causes, except financial, that are beyond the reasonable control of DISTRICT or CONTRACTOR, for a period of time equal to the period of such force majeure event, provided that the party failing to perform notifies the other party within fifteen calendar days of discovery of the force majeure event, and provided further that that party takes all reasonable action to mitigate the damages resulting from the failure to perform. Notwithstanding the above, if the cause of the force majeure event is due to a party's own action or inaction, then such cause shall not excuse that party from performance under this Contract.

23. SEVERABILITY – If a court of competent jurisdiction holds any provision of this Contract to be illegal, unenforceable or invalid, in whole or in part, for any reason, the validity and enforceability of the remaining provisions, or portions of them, will not be affected.
24. HEADINGS – Headings on the sections and paragraphs of this Contract are for convenience and reference only, and the words contained therein, shall in no way be held to explain, modify, amplify, or aid in the interpretation, construction, or meaning of the provisions of this Contract.
25. COUNTERPARTS/FACSIMILES/SCANS – This Contract may be executed and delivered in any number of counterparts, each of which, when executed and delivered, shall be deemed an original, and all of which together shall constitute the same contract. The parties may rely upon a facsimile copy or scanned copy of any party's signature as an original for all purposes.
26. GOVERNING LAW – Any dispute that arises under or relates to this Contract shall be governed by California law, excluding any laws that direct the application of another jurisdiction's laws. Venue for resolution of any dispute that arises under or relates to this Contract, including mediation, shall be San Francisco, California.
27. ENTIRE CONTRACT AND MODIFICATION – This Contract represents the final, complete, and exclusive statement of the agreement between the parties related to CONTRACTOR providing services to DISTRICT, and supersedes all prior and contemporaneous understandings and agreements of the parties. No party has been induced to enter into this Contract by, nor is any party relying upon, any representation or warranty outside those expressly set forth herein. This Contract may only be amended by mutual agreement of the parties in writing and signed by both parties.
28. SURVIVAL OF TERMS – The provisions of sections 7 (Indemnification), 13 (Confidentiality), 14 (Intellectual Property Rights), and 15 (Publication) shall survive the expiration or termination of this Contract.

IN WITNESS WHEREOF, the parties to this Contract have caused this Contract to be duly executed on their behalf by their authorized representatives.

BAY AREA AIR QUALITY  
MANAGEMENT DISTRICT

ACTERRA

Signed by:  
By:   
98508AF9881D4CC  
Dr. Philip M. Fine  
Executive Officer/APCO

By:   
Lauren Weston  
Executive Director

Date: 7/3/2025

Date: 6/25/25

Approved as to form:

DocuSigned by:  
By:  7/1/2025  
6DC7110552B5463...  
Alexander G. Crockett  
General Counsel

## **ATTACHMENT A**

### **SCOPE OF WORK**

#### **Overview**

DISTRICT convenes an Assembly Bill (AB) 617 Community Steering Committee (CSC) in Bayview Hunters Point/ Southeast San Francisco that informs the development of a Community Emissions Reduction Plan (CERP). CONTRACTOR will support administration, logistics, and moderate monthly public CSC meetings in Bayview Hunters Point. The monthly CSC meetings are held in the evenings, typically on the third Tuesday of the month in Bayview Hunters Point San Francisco. CONTRACTOR will work collaboratively with Co-Leads, DISTRICT staff, CSC member Co-Chairs and CSC members. CONTRACTOR's collaborative tasks will include providing support, including the creation of public agenda, detailed facilitation plan, meeting presentations, and materials, translate materials, moderate the CSC meetings, provide meals/refreshments, secure a meeting location, and provide simultaneous language interpretation as needed. CONTRACTOR will also work with DISTRICT staff to provide monthly stipend payments for CSC members' time to attend CSC meetings, subcommittee meetings and other DISTRICT-approved CERP-related activities, and reimbursements for transportation and childcare. CSC meetings last for up to 2.5 hours, with additional time for setting up and cleaning up.

#### **Task 1: CSC Meeting Planning and Coordination**

- a. Through meeting participation and a review of all relevant background materials provided by the DISTRICT, CONTRACTOR will gain an understanding of DISTRICT's CERP process goals, objectives, and concerns and the progress made on the project.
- b. CONTRACTOR will assign a project manager approved by DISTRICT to join up to three (3) planning meetings per month for CSC meetings with Co-Leads and Co-Chairs and support development of a facilitation plan, public agenda, meeting presentation, and handout materials. CONTRACTOR will join up to four (4) additional logistical meetings per month with the DISTRICT staff. CONTRACTOR will take detailed notes for the planning and logistical meetings, and upon DISTRICT request, will facilitate these meetings. Planning meeting agendas should follow a meeting template provided by the DISTRICT and should have action item review, updates, discussion and action items. CONTRACTOR will finalize agendas with DISTRICT staff by the mornings of planning meetings. CONTRACTOR's meeting notes will be detailed and shall include the speaker of each remark, clear action items with a person assigned, the action item and a deadline. Meeting notes should be completed by the end of the day of the meeting.
- c. Each month, CONTRACTOR will develop a template public agenda, detailed facilitation plan and public meeting presentation decks and support DISTRICT, Co-Leads, and Co-Chairs in completing the agendas in a timely manner. The template documents are a starting point for DISTRICT, Co-Leads, and Co-Chairs to provide input and draft detailed information to share with the public. Public meeting presentation decks will include all DISTRICT staff presentations, intro, ending, break, and breakout activity slides as well as any other slides needed for the public meeting. CONTRACTOR's project manager will use an online document storage space, such as a Google Drive Folder, to facilitate document sharing and collective

editing processes. These materials include the final detailed facilitation plan, presentation deck, translated materials, online board exports, meeting recordings, audio recordings of interpretation, and any other materials used during the meeting. The public agenda will be posted to DISTRICT website ten (10) business days before CSC meeting. Final meeting slides and handouts will be posted to DISTRICT website at least 72 hours before each CSC meeting.

- d. CONTRACTOR shall accommodate a DISTRICT review process, including the DISTRICT's desired presentation of material, activities, and support. CONTRACTOR will provide advice on using language that is easy for the public to digest, community-friendly and engaging for a diverse range of audiences while staying focused on DISTRICT's goals.
- e. CONTRACTOR will develop, administer, and summarize monthly meeting evaluations to gather feedback from CSC on the meeting contents, activities, format, and meeting facilitation. Evaluations will be shared and discussed during CSC debrief meetings with the DISTRICT, Co-Leads, and Co-Chairs. The monthly debrief meeting counts as one (1) of the three (3) planning meetings per month.
- f. CONTRACTOR will create a CSC meeting calendar invitation and maintain a contact list in collaboration with DISTRICT by the 1<sup>st</sup> of the month. Contacts will be stored and maintained in a spreadsheet by DISTRICT.
- g. CONTRACTOR will review a draft Communications Protocol within ten (10) days of Contract execution. DISTRICT will provide the draft Communications Protocol to CONTRACTOR for review, including various items that get communicated to the CSC, responsible organization for communications tasks and a list of DISTRICT staff that should be copied on communications.

***Deliverables:***

- Review of DISTRICT-provided materials, including but not limited to past meeting presentations and agendas, emails to the CSC, budget, stipend forms;
- Up to four (4) Logistical meetings with CONTRACTOR and DISTRICT staff and agendas by morning of meetings and detailed notes with action items;
- Up to three (3) planning meetings with CONTRACTOR, DISTRICT staff, Co-lead partners and Co-chairs and agendas by morning of meetings and detailed notes with action items;
- Template and review of detailed facilitation plan;
- Translated Public Agendas to be delivered to DISTRICT by 10 business days before CSC meeting
- Email Final Meeting Materials, including the public agenda and slide decks, to DISTRICT by noon the Thursday before each CSC meeting scheduled for a Tuesday evening. If the CSC meeting is scheduled for an alternate day of the week, CONTRACTOR shall confirm the deadline for submission with the DISTRICT at least two weeks in advance;
- Template Meeting Evaluation and Evaluation Summary shared during CSC debrief meetings;
- Document coordination and distribution through online document storage and maintain folders;
- CSC meeting invitation list updated 1<sup>st</sup> of the month, as needed; and
- Provide feedback and suggested revisions on the draft Communications Protocol within ten (10) days of contract execution.

## **Task 2: Public CSC Meeting Facilitation, Technical Assistance, & Meeting Support Staff**

Upon DISTRICT request, CONTRACTOR shall assign a senior-level staff approved by DISTRICT to facilitate and emcee the meeting. CONTRACTOR's additional role may include the following roles based on assignments made by DISTRICT, Co-Leads and Co-Chairs: welcoming attendees, introducing the presenters at the beginning of the meeting and between meeting topics, leading Q&A, facilitating activities, timekeeping, and closing out the meeting. CONTRACTOR will provide meeting attendance sheet for CSC members and technical advisory group members every CSC meeting, complete the attendance sheets during CSC meetings, and have the sheets reviewed by DISTRICT staff per the attendance protocol. CONTRACTOR will photograph and type up meeting notes from discussion and activities, including hand-written notes on poster paper or sticky notes, within five (5) business days after each CSC meeting. CONTRACTOR will prepare meeting summaries following DISTRICT's template and guidance. Meeting summaries shall be completed within 5 business days after each CSC meeting and include a report on monthly CSC meeting overall turnout of attendees.

For hybrid meetings, CONTRACTOR support staff will conduct the following: manage meeting participants and enabling/disabling mute buttons, monitor the chat, including sending messages, capturing comments and questions, and enabling and disabling chat at the appropriate times, timekeep, create and communicate timing with the project team in a backroom communications channel, monitor participants, enabling and disabling audio at the appropriate times, admitting participants, ensuring participant names are appropriate, booting any "zoom bombers", etc., take notes on Miro boards or otherwise to capture participant feedback (as needed), monitor for questions, and comments to bring to DISTRICT staff attention. CONTRACTOR's staff will also provide technical assistance for the meeting including setting up the meeting with appropriate features enabled via Zoom, admitting attendees, conducting the technical aspects of virtual meeting features, recording, and filing of meeting recordings, monitoring the chat and Q&A, troubleshooting any issues that may occur.

For in-person meetings, CONTRACTOR will ensure meeting location has appropriate space, space configuration and sufficient microphones for presenters and audience members, , arrange for and test audio/visual need and capabilities, develop meeting flow design, bring and set up audio/ visual technology, arrange presentation order, facilitate discussion, timekeep, pass the microphone for participants, and document meeting discussions in a way visible to attendees. CONTRACTOR will add meeting facilitation details to the detailed facilitation plan. CONTRACTOR and DISTRICT will conduct a technical run-through meeting for first CSC meeting and at any new venue and add details and check-list to the detailed facilitation plan.

**Deliverables:** Upon DISTRICT request, staffing support including:

- Meeting Facilitation with notes and check-list added to detailed facilitation plan;
- In-person Technical Support and technical run-through meeting and details added to detailed facilitation plan;
- Additional Support Staff for CSC meetings and technical support for hybrid meetings;
- Arrange for, set up and test Audio/Visual Equipment;
- Meeting Summaries following DISTRICT's template and guidance completed within 5 business days after each CSC meeting, including report on monthly CSC meeting overall turnout of attendees;

- CSC Member and technical advisory group member attendance sheet filled out and reviewed by DISTRICT staff within 5 days of CSC meeting; and
- Photograph and type up meeting notes taken down on paper or poster paper within five (5) business days after each CSC meeting;
- Post CSC Meeting Recordings, including live captioning, Chat Transcript within five (5) business days after each virtual/hybrid CSC meeting;
- Zoom Links for panelists and general participants, if hybrid meeting;
- Zoom Technical Support, if hybrid meeting.

**Task 3. Community Emissions Reduction Plan (CERP) Document Production**

CONTRACTOR will support production of the CERP document (estimated 200-page document), including an Executive Summary. CONTRACTOR will review and adhere to CERP Production Guidelines document, which will be provided by DISTRICT, including document accessibility requirements. CONTRACTOR will provide administrative support, which includes, but is not limited to: creating a CERP document template, coordinating with DISTRICT staff to assemble various sections of the CERP, checking formatting, formatting graphics, editing document to adhere to The Americans with Disabilities Act (ADA) accessibility requirements for the public to review the draft and final copies, both digital and hard copies. CONTRACTOR shall not make substantive changes to the document. CONTRACTOR will use Microsoft Word only and follow the DISTRICT style-guide for formatting, font, and color-scheme. CONTRACTOR will meet with DISTRICT staff regularly for planning and logistical purposes, and CONTRACTOR project manager will coordinate and set up an online document sharing process. CONTRACTOR will review and reformat the CERP and shall accommodate up to four rounds of review, and allow for time for translation of the Public Draft and Final CERP document into other languages as required by DISTRICT language access plan guidelines. The CERP may go through various stages of editing and there will be multiple versions, including CSC review draft, Public Draft, DISTRICT Board Draft, and Final CERP. DISTRICT is responsible for translation of the CERP.

***Deliverables:***

- Template CERP document;
- Draft and Final CERP document that meets DISTRICT requirements, including up to four rounds of review per DISTRICT’s public review process timeline;
- Schedule of production process with roles and deadlines for review, approved by DISTRICT; and
- Review of Public Draft CERP and subsequent edits and Final CERP for style-guide and ADA requirements.

**Task 4. Reporting**

CONTRACTOR will collect and provide required information about jobs created, such as title, required education, hours worked in the period, etc., to California Air Resources Board (CARB) to meet CARB’s reporting requirements two (2) times per year.

***Deliverables:***

- Completed spreadsheet with descriptive data on jobs created reported to DISTRICT two (2)

times per year.

**Task 5. Staff Training**

CONTRACTOR agrees to complete a workplace training on preventing a hostile work environment (including illegal discrimination, harassment, and bullying). The training must either be provided by or approved by DISTRICT and provide a certificate of completion or other proof of completion of the training for each employee who will regularly work with DISTRICT staff and/or CSC members. If additional employees are hired or assigned to regularly work with DISTRICT staff and/or CSC members after the Contract or applicable amendments are executed, CONTRACTOR shall have sixty (60) days from the date of each employee’s hiring or assignment to provide that employee’s certificate of completion or other proof of completion to [HR\\_Staff@baaqmd.gov](mailto:HR_Staff@baaqmd.gov) and [ab617info@baaqmd.gov](mailto:ab617info@baaqmd.gov).

***Deliverables:***

- Certificate of completion or proof of completion emailed to [HR\\_Staff@baaqmd.gov](mailto:HR_Staff@baaqmd.gov) and [ab617info@baaqmd.gov](mailto:ab617info@baaqmd.gov) for each employee.

**Task 6: CSC Meeting Logistics, Stipends and Reimbursements**

Upon approval by DISTRICT, CONTRACTOR will administer stipend payments to up to twenty-five (25) eligible CSC members. DISTRICT will provide a draft Stipend Disbursement Protocol, including a protocol for attendance verification and communications. CONTRACTOR will review the draft Stipend Disbursement Protocol within ten (10) days of contract execution, to be finalized by DISTRICT within 30 days of contract execution. CONTRACTOR will coordinate collection of annual tax forms (W-9) and provide a paper copy of the 1099’s to CSC members in via mail, by January 31 of the following calendar year. CONTRACTOR will send 1099’s electronically following CSC members’ consent and must be sent in a secure manner such as with file encryption or secure email services. CONTRACTOR’s consent process will clearly indicate how the CSC member chooses to access the tax form. CONTRACTOR’s distribution of 1099’s must comply with IRS and California tax regulations. CSC members will be compensated at a rate of \$75 per hour for pre-approved CERP-related activities and per the CSC charter. CONTRACTOR will collaborate with DISTRICT staff to create a stipend reimbursement form that’s approved by DISTRICT and distribute stipends on an invoice and reimbursement basis monthly, processing payment request forms by 2 weeks after each CSC meeting. CONTRACTOR shall make available and shall provide various forms of payment, such as direct deposit, checks, or gift cards and shall be able to make payments of up to \$6,000 per month. Transportation reimbursement will be based on current Internal Revenue Service standard mileage rates, or on actual cost of other forms of transportation, as determined from CSC members providing receipts for other forms of transportation with a cap at \$25 per CSC member per month (the 2025 standard mileage rate is 70 cents per mile). CONTRACTOR will track stipends and reimbursements by 15<sup>th</sup> of each month, provide proof of payment to DISTRICT in monthly invoices, monthly reports on stipend spend down and follow up with CSC members to ensure the processing of payments. CONTRACTOR will also provide an end-of-year summary of stipend disbursements by member by January 31 for past calendar year.

CONTRACTOR will acquire Southeast Community Center (SECC), as available, or another transit-accessible venue for monthly CSC meetings, upon DISTRICT approval of the venue and cost, at least 1

month in advance. For the CSC meetings, CONTRACTOR will procure and provide food and refreshments, including bio-degradable silverware and cups (no plastic). DISTRICT shall provide approval of the catering menu and the quote prior to CONTRACTOR procuring food and refreshments.

CONTRACTOR will print CSC meeting materials (agenda, slides, and handouts) in color, two-sided format. CONTRACTOR will print at least two copies in Spanish and Chinese.

***Deliverables:***

- Provide feedback and suggested revisions on the draft Stipend Disbursement Protocol, including protocol for attendance verification and communications, within ten (10) days of contract execution;
- Collection of W-9's from CSC members;
- 1099's provided to CSC members by January 31 for the past calendar year;
- Stipend reimbursement form;
- Process payment of CSC monthly member stipends, transportation and childcare reimbursements by 2 weeks after each CSC meeting;
- Provide itemized proof of payment to CSC members and update tracking spreadsheet with invoice or by the 15<sup>th</sup> of each month;
- Secure SECC or another DISTRICT-approved venue for in-person meetings, at least 1 month in advance;
- Secure DISTRICT approval of food menu;
- Provide receipts for CSC meeting food and venue;
- Printed CSC meeting materials for 50 participants and at least two copies in Spanish and Chinese;
- Tracking and monitoring of monthly and overall stipend spend down with reports monthly;
- End-of-year summary of stipend disbursements by member and a record of 1099 distribution by January 31 for past calendar year; and
- Invoices and supporting documentation by the end of the month for the previous month.

**Task 7: As-needed Translation and Simultaneous Interpretation**

CONTRACTOR will translate the public meeting deck into Spanish and Chinese by three days in advance of the public meeting. Other languages will be based on requests from the public.

Upon DISTRICT request, CONTRACTOR will provide live simultaneous interpretation at the meeting. CONTRACTOR will work closely with DISTRICT to field simultaneous interpretation requests. DISTRICT asks the public for requests no later than three (3) business days in advance of the public meeting. Upon DISTRICT request, CONTRACTOR will include a presentation slide with instructions on how to access the interpretation at the start of the meeting, provide simultaneous interpretation into the language(s) requested, and for hybrid meetings, share a post-meeting audio recording of the interpretation channel. CONTRACTOR's interpretation services include preparation, 30-minutes early arrival to meetings, and up to two and a half (2.5) hours of simultaneous interpretation. For in-person meetings, CONTRACTOR will provide interpretation equipment in-kind.

***Deliverables:***

- Translation of materials into Spanish and Chinese to be posted to DISTRICT website within 72

hours of CSC meeting;

- Simultaneous Interpretation from English to two other languages, as requested; and
- For in-person meetings, provide headsets and microphones for simultaneous interpretation, in-kind.

**ATTACHMENT B**

**COST SCHEDULE**

DISTRICT will pay CONTRACTOR on an hourly basis for the services described in Attachment A, Scope of Work, in accordance to Table 1 below. CONTRACTOR will invoice DISTRICT monthly for the hours worked and other direct costs incurred in the prior month. DISTRICT shall pay CONTRACTOR within thirty (30) days following DISTRICT receipt and approval of CONTRACTOR’s invoice. Invoicing and payments will be made in accordance to Section 8, Payment, of this Contract.

**Table 1 - Hourly Rates**

| <b>Name</b>             | <b>Job Title</b>                     | <b>Hourly Rate</b> |
|-------------------------|--------------------------------------|--------------------|
| Lauren Weston           | Executive Director                   | \$161.87           |
| Genevieve Lucas-Conwell | Director of Programs                 | \$97.00            |
| Zack Wurtz              | Director of Operations               | \$86.17            |
| TBD                     | Project Senior Manager               | \$69.75            |
| TBD                     | Research Manager                     | \$60.00            |
| Michelle Kim            | Operations Manager                   | \$54.94            |
| TBD                     | Program Associate                    | \$48.10            |
| TBD                     | Outreach Specialist (Translation)    | \$75.00            |
| TBD                     | Outreach Specialist (Interpretation) | \$90.00            |

DISTRICT will pay CONTRACTOR for general direct costs to complete the work described in Attachment A, Scope of Work in accordance to Table 2 below. Direct cost may be reallocated if CONTRACTOR receives written approval from the DISTRICT via email prior to exceeding the amount. Reallocation may not result in the Contract NTE for general direct costs (\$71,141) being exceeded.

**Table 2 - Not to Exceed General Direct Costs**

| <b>Direct Cost Item</b>                      | <b>Cost per Unit</b>           | <b>Cost</b>        |
|--|--------------------------------|--------------------|
| Venue for in-person meetings                 | \$1,125.00                     | \$9,000.00         |
| Refreshments and Food for in-person meetings | \$1,000.00                     | \$8,000.00         |
| Printed Materials                            | \$180.00                       | \$1,440.00         |
| Stipends                                     | \$75.00                        | \$48,101.00        |
| Childcare Reimbursements                     | \$450.00                       | \$3,600.00         |
| Transportation Reimbursements                | \$125.00                       | \$1,000.00         |
| Interpretation Equipment                     | CONTRACTOR will supply in-kind | \$0.00             |
|  | <b>Total</b>                   | <b>\$71,141.00</b> |

The following Not to Exceed (NTE) amount in Table 3 describes the anticipated labor cost for each Task. The NTE may be reallocated between tasks if CONTRACTOR receives written approval from the DISTRICT via email prior to exceeding the amount for the task. Reallocation of funds may not result in the Contract NTE for labor costs (\$127,859) being exceeded.

**Table 3 – Not to exceed Labor Costs by Task**

| <b>Task</b> | <b>Description</b>   | <b>Not-to-Exceed Amount</b> |
|-------------|--|-----------------------------|
| 1           | CSC Meeting Planning and Coordination  | \$42,717.00                 |
| 2           | Public CSC Meeting Facilitation, Technical Assistance, & Meeting Support Staff | \$22,822.00                 |
| 3           | Community Emissions Reduction Plan (CERP) Document Production                  | \$21,633.00                 |
| 4           | Reporting  | \$340.00                    |
| 5           | Staff Training   | \$1,683.00                  |
| 6           | CSC Meeting Logistics, Stipends and Reimbursements                             | \$29,664.00                 |
| 7           | As-needed Translation and Simultaneous Interpretation                          | \$9,000.00                  |
|             | Total  | <b>\$127,859.00</b>         |

**Total cost of Contract not to exceed \$199,000.**

**AMENDMENT NO. 1 TO**  
**BAY AREA AIR QUALITY MANAGEMENT DISTRICT**  
**CONTRACT NO. 2025.171**

This amendment to the above-entitled contract (“Contract Amendment”) is dated, for reference purposes only, March 31, 2026.

**RECITALS:**

1. The Bay Area Air Quality Management District (“DISTRICT”) and **Acterra** (“CONTRACTOR”) (hereinafter referred to as the “PARTIES”) entered into the above-entitled contract to support DISTRICT’s Community Steering Committee (CSC) in Bayview Hunters Point / Southeast San Francisco in administration, logistics, and moderate monthly public CSC meetings in Bayview Hunters Point. (the “Contract”), which Contract was executed on behalf of CONTRACTOR on June 25, 2025, and on behalf of DISTRICT on July 3, 2025.
2. The PARTIES seek to extend the term to the Contract because the DISTRICT seeks to continue receiving services from CONTRACTOR prescribed in the Contract and CONTRACTOR desires to provide those services.
3. In accordance with Section 27 of the Contract, DISTRICT and CONTRACTOR desire to amend the above-entitled Contract as follows:

**TERMS AND CONDITIONS OF CONTRACT AMENDMENT:**

1. By this Contract Amendment, DISTRICT and CONTRACTOR amend Section 4, “Term.” The term of the Contract shall be extended so that the termination date of the Contract is now May 31, 2026.
2. DISTRICT and CONTRACTOR agree that all other terms and conditions of the Contract shall remain in full force and effect.

IN WITNESS WHEREOF, the PARTIES have caused this Contract Amendment to be duly executed on their behalf by their authorized representatives.

BAY AREA AIR QUALITY  
MANAGEMENT DISTRICT

ACTERRA

By:   
\_\_\_\_\_  
Signed by:  
Philip M. Fine  
Executive Officer/APCO

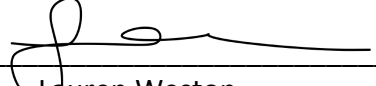
By:   
\_\_\_\_\_  
Lauren Weston  
Executive Director

Date: 4/8/2026

Date: 4/7/2026

Approved as to form:

By:   
\_\_\_\_\_  
Signed by:  
Alexander G. Crockett  
General Counsel  
4/8/2026

**AMENDMENT NO. 2 TO**  
**BAY AREA AIR QUALITY MANAGEMENT DISTRICT**  
**CONTRACT NO. 2025.171**

This amendment to the above-entitled contract (“Contract Amendment”) is dated, for reference purposes only, April 15, 2026.

**RECITALS:**

1. The Bay Area Air Quality Management District (“DISTRICT”) and **Acterra** (“CONTRACTOR”) (hereinafter referred to as the “PARTIES”) entered into the above-entitled contract to support DISTRICT’s Community Steering Committee (CSC) in Bayview Hunters Point / Southeast San Francisco in administration, logistics, and moderate monthly public CSC meetings in Bayview Hunters Point. (the “Contract”), which Contract was executed on behalf of CONTRACTOR on June 25, 2025, and on behalf of DISTRICT on July 3, 2025.
2. The PARTIES entered into Amendment No. 1 to the Contract, dated March 31, 2026, for reference purposes only, to extend the term of the Contract.
3. The PARTIES seek to amend the term, total cost, Scope of Work and Cost Schedule to the Contract because the DISTRICT seeks to continue receiving services from CONTRACTOR prescribed in the Contract and CONTRACTOR desires to provide those services.
4. In accordance with Section 27 of the Contract, DISTRICT and CONTRACTOR desire to amend the above-entitled Contract as follows:

**TERMS AND CONDITIONS OF CONTRACT AMENDMENT:**

1. By this Contract Amendment, DISTRICT and CONTRACTOR amend Section 4, “Term.” The term of the Contract shall be extended so that the termination date of the Contract is now September 30, 2027.
2. By this Contract Amendment, DISTRICT and CONTRACTOR amend Paragraph D of Section 8, “Payment,” of the Contract to replace “\$199,000” with “\$590,208.”
3. By this Contract Amendment, DISTRICT and CONTRACTOR amend Paragraph F of Section 9, “Dispute Resolution,” of the Contract to replace “\$199,000” with “\$590,208.”
4. By this Contract Amendment, DISTRICT and CONTRACTOR replace Attachment A, Scope of Work, with the attached “Attachment A-1, Scope of Work” and agree that all

references in the Contract to Attachment A shall be deemed to refer to Attachment A-1, Scope of Work.

5. By this Contract Amendment, DISTRICT and CONTRACTOR replace Attachment B, Cost Schedule, with the attached "Attachment B-1, Cost Schedule" and agree that all references in the Contract to Attachment B shall be deemed to refer to Attachment B-1, Cost Schedule.
6. DISTRICT and CONTRACTOR agree that all other terms and conditions of the Contract shall remain in full force and effect.

IN WITNESS WHEREOF, the PARTIES have caused this Contract Amendment to be duly executed on their behalf by their authorized representatives.

BAY AREA AIR QUALITY  
MANAGEMENT DISTRICT

ACTERRA

By: \_\_\_\_\_  
Philip M. Fine  
Executive Officer/APCO

By: \_\_\_\_\_  
Lauren Weston  
Executive Director

Date: \_\_\_\_\_

Date: \_\_\_\_\_

Approved as to form:

By: \_\_\_\_\_  
Alexander G. Crockett  
General Counsel

## ATTACHMENT A-1

### SCOPE OF WORK

#### Overview

DISTRICT convenes an Assembly Bill (AB) 617 Community Steering Committee (CSC) in Bayview Hunters Point/ Southeast San Francisco. The CSC informs the development of a Community Emissions Reduction Plan (CERP). CONTRACTOR will support the DISTRICT in meeting state requirements by providing third-party, neutral logistical support, language and other accessibility needs and disbursing stipends and reimbursements for public CSC process.

The monthly CSC meetings are held in the evenings, typically on the third Tuesday of the month in Bayview Hunters Point San Francisco. CONTRACTOR will work collaboratively with Co-Leads, DISTRICT staff, CSC member Co-Chairs and CSC members. CONTRACTOR's collaborative tasks will include providing support, including the creation of public agenda, detailed facilitation plan, meeting presentations, and materials, translate materials, provide meals/refreshments, secure a meeting location, and provide simultaneous language interpretation as needed. CONTRACTOR will also work with DISTRICT staff to provide monthly stipend payments for CSC members' time to attend CSC meetings, subcommittee meetings and other DISTRICT-approved CERP-related activities, and reimbursements for transportation and childcare. CSC meetings typically last for up to 2.5 hours, with additional time for setting up and cleaning up.

#### Task 1: CSC Meeting Planning and Coordination

- a. Through meeting participation and a review of all relevant background materials provided by the DISTRICT, CONTRACTOR will gain an understanding of DISTRICT's CERP process goals, objectives, and concerns and the progress made on the project.
- b. For each virtual meeting, CONTRACTOR will host the remote portion of the meeting via Zoom and will provide Co-Host access to DISTRICT. CONTRACTOR will assign a project manager approved by DISTRICT to join up to three (3) planning meetings per month for CSC meetings with Co-Leads and Co-Chairs. CONTRACTOR will join up to four (4) additional logistical meetings per month with the DISTRICT staff. CONTRACTOR will take detailed neutral notes for the planning and logistical meetings. Planning meeting agendas should follow a meeting template provided by the DISTRICT and should have action item review, updates, discussion and action items. CONTRACTOR will finalize agendas with DISTRICT staff by the mornings of planning meetings. CONTRACTOR's meeting notes will be detailed and shall include the speaker of each remark, clear action items with a person assigned, the action item and a deadline. Meeting notes should be completed by the end of the day of the meeting.

CONTRACTOR's project manager will use DISTRICT's preferred online document storage space, to facilitate document sharing and collective editing processes. These materials include the final detailed facilitation plan, presentation deck, translated materials, online board exports, meeting recordings, audio recordings of interpretation, and any other materials used during the meeting. The public agenda will be posted to DISTRICT website ten (10) business days before CSC meeting. Final meeting slides and handouts will be posted to DISTRICT website at least 72 hours before each CSC meeting.

CONTRACTOR shall accommodate a DISTRICT review process, including the DISTRICT's desired presentation of material, activities, and support.

- c. CONTRACTOR will develop, administer, and summarize monthly meeting evaluations to gather feedback from CSC on the meeting contents, activities, format, and meeting facilitation. Evaluations will be shared and discussed during CSC debrief meetings with the DISTRICT, Co-Leads, and Co-Chairs. The monthly debrief meeting counts as one (1) of the three (3) planning meetings per month.
- d. CONTRACTOR will create a CSC meeting calendar invitation and maintain a contact list in collaboration with DISTRICT by the 1<sup>st</sup> of the month. Contacts will be stored and maintained in a spreadsheet by DISTRICT.
- e. CONTRACTOR will review a draft Communications Protocol within ten (10) days of Contract execution. DISTRICT will provide the draft Communications Protocol to CONTRACTOR for review, including various items that get communicated to the CSC, responsible organization for communications tasks and a list of DISTRICT staff that should be copied on communications.
- f. CONTRACTOR will translate the public meeting deck into Spanish and Chinese at least three days in advance of the public meeting. Other languages will be based on requests from the public. DISTRICT will provide materials no later than five (5) business days prior to when the translations are needed. DISTRICT will discuss an appropriate turnover time frame for translation with CONTRACTOR for translations requests requiring more than five business days to complete.
- g. Upon DISTRICT request, CONTRACTOR will provide live simultaneous interpretation during meetings. CONTRACTOR will work with DISTRICT to field simultaneous interpretation requests. DISTRICT will seek requests from the public no later than three (3) business days in advance of the public meeting. Upon DISTRICT request, CONTRACTOR will include a presentation slide with instructions on how to access the interpretation at the start of the meeting, provide simultaneous interpretation into the language(s) requested, and for hybrid meetings, share a post-meeting audio recording of the interpretation channel. CONTRACTOR's interpretation services shall include preparation, 30-minutes early arrival to meetings, and up to two and a half (2.5) hours of simultaneous interpretation. For in-person meetings, CONTRACTOR will provide interpretation equipment in-kind.

***Deliverables:***

- Review of DISTRICT-provided materials, including but not limited to past meeting presentations and agendas, emails to the CSC, budget, stipend forms;
- Up to four (4) Logistical meetings with CONTRACTOR and DISTRICT staff and agendas by morning of meetings and detailed notes with action items;
- Up to three (3) planning meetings with CONTRACTOR, DISTRICT staff, Co-lead partners and Co-chairs and agendas by morning of meetings and detailed notes with action items;
- Review of detailed facilitation plan;
- Translated Public Agendas to be delivered to DISTRICT by 10 business days before CSC meeting
- Email Final Meeting Materials, including the public agenda and slide decks, to DISTRICT by noon

the Thursday before each CSC meeting scheduled for a Tuesday evening. If the CSC meeting is scheduled for an alternate day of the week, CONTRACTOR shall confirm the deadline for submission with the DISTRICT at least two weeks in advance;

- Template Meeting Evaluation and Evaluation Summary shared during CSC debrief meetings;
- Document coordination and distribution through online document storage and maintain folders;
- CSC meeting invitation list updated 1<sup>st</sup> of the month, as needed;
- Provide feedback and suggested revisions on the draft Communications Protocol within ten (10) days of contract execution;
- Translation of materials into Spanish and Chinese to be posted to DISTRICT website within 72 hours of each CSC meeting;
- Provide receipts for each CSC meeting materials translation and simultaneous interpretation in monthly invoice packets;
- Simultaneous Interpretation from English to two other languages, as requested;
- For in-person meetings, provide headsets and microphones for simultaneous interpretation, in-kind;
- Zoom Links for panelists and general participants, if virtual meeting; and
- Zoom Technical Support, if virtual meeting.

**Task 2: Public CSC Meeting Coordination, Technical Assistance, & Meeting Support**

- a) Upon DISTRICT request, CONTRACTOR shall assign a senior-level staff approved by DISTRICT to facilitate and emcee the meeting. CONTRACTOR's additional role may include the following roles based on assignments made by DISTRICT, Co-Leads and Co-Chairs: welcoming attendees, introducing the presenters at the beginning of the meeting and between meeting topics, leading Q&A, facilitating activities, timekeeping, and closing out the meeting. CONTRACTOR will provide meeting attendance sheet for CSC members and technical advisory group members every CSC meeting, complete the attendance sheets during CSC meetings, and have the sheets reviewed by DISTRICT staff per the attendance protocol. CONTRACTOR will photograph and type up meeting notes from discussion and activities, including hand-written notes on poster paper or sticky notes, within five (5) business days after each CSC meeting. CONTRACTOR will prepare meeting summaries following DISTRICT's template and guidance. Meeting summaries shall be completed within 5 business days after each CSC meeting and include a report on monthly CSC meeting overall turnout of attendees.
- b) For each hybrid meeting, CONTRACTOR will host the remote portion of the meeting via Zoom and will provide Co-Host access to DISTRICT. CONTRACTOR support staff will conduct the following: manage meeting participants and enabling/disabling mute buttons, monitor the chat, including sending messages, capturing comments and questions, and enabling and disabling chat at the appropriate times, timekeep, create and communicate timing with the project team in a backroom communications channel, monitor participants, enabling and disabling audio at the appropriate times, admitting participants, ensuring participant names are appropriate, booting any "zoom bombers", etc., take notes on Miro boards or otherwise to capture participant feedback (as needed), monitor for questions, and comments to bring to DISTRICT staff attention. CONTRACTOR's staff will also provide technical assistance for the meeting including setting up the meeting with appropriate features enabled via Zoom, admitting attendees, conducting the technical aspects of virtual meeting features, recording, and filing of meeting recordings, monitoring the chat and Q&A, troubleshooting any issues that may occur.

- c) For in-person meetings, CONTRACTOR will ensure meeting location has appropriate space, space configuration and sufficient microphones for presenters and audience members, , arrange for and test audio/visual needs and capabilities, develop meeting flow design, bring and set up audio/ visual technology, arrange presentation order, facilitate discussion, timekeep, pass the microphone for participants, and document meeting discussions in a way visible to attendees. CONTRACTOR and DISTRICT will conduct a technical run-through meeting for first CSC meeting and at any new venue and add details and check-list to the detailed facilitation plan.

**Deliverables:** Upon DISTRICT request, staffing support including:

- In-person Technical Support and technical run-through meeting and details added to detailed facilitation plan;
- Additional Support Staff for CSC meetings and technical support for hybrid meetings;
- Arrange for, set up and test Audio/Visual Equipment;
- Meeting Summaries following DISTRICT’s template and guidance completed within 5 business days after each CSC meeting, including report on monthly CSC meeting overall turnout of attendees;
- CSC Member and technical advisory group member attendance sheet filled out and reviewed by DISTRICT staff within 5 days of CSC meeting; and
- Photograph and type up meeting notes taken down on paper or poster paper within five (5) business days after each CSC meeting;
- Post CSC Meeting Recordings, including live captioning, Chat Transcript within five (5) business days after each virtual/hybrid CSC meeting;
- Zoom Links for panelists and general participants, if hybrid meeting;
- Zoom Technical Support, if hybrid meeting.

### **Task 3. Reporting**

CONTRACTOR will collect and provide required information about jobs created, such as title, required education, hours worked in the period, etc., to California Air Resources Board (CARB) to meet CARB’s reporting requirements two (2) times per year. CONTRACTOR should submit the report to DISTRICT no later than, in April 30 and October 31, unless otherwise instructed by DISTRICT in communications.

**Deliverables:**

- Completed spreadsheet with information about jobs reported to DISTRICT two (2) times per year no later than May 15 and November 15 each calendar year, unless otherwise directed by DISTRICT.

### **Task 4. Staff Training**

CONTRACTOR agrees to complete a workplace training on preventing a hostile work environment (including illegal discrimination, harassment, and bullying). The training must either be provided by or approved by DISTRICT and provide a certificate of completion or other proof of completion of the training for each employee who will regularly work with DISTRICT staff and/or CSC members. If additional employees are hired or assigned to regularly work with DISTRICT staff and/or CSC members after the Contract or applicable amendments are executed, CONTRACTOR shall have sixty (60) days from the date of each employee’s hiring or assignment to provide that employee’s certificate of completion or other

proof of completion to [HR\\_Staff@baaqmd.gov](mailto:HR_Staff@baaqmd.gov) and [ab617info@baaqmd.gov](mailto:ab617info@baaqmd.gov).

**Deliverables:**

- Certificate of completion or proof of completion emailed to [HR\\_Staff@baaqmd.gov](mailto:HR_Staff@baaqmd.gov) and [ab617info@baaqmd.gov](mailto:ab617info@baaqmd.gov) for each employee.

**Task 5: CSC Meeting Logistics, Stipends and Reimbursements**

- a) Upon approval by DISTRICT, CONTRACTOR will administer stipend payments to up to twenty-five (25) eligible CSC members. DISTRICT will provide a draft Stipend Disbursement Protocol, including a protocol for attendance verification and communications. CONTRACTOR will review the draft Stipend Disbursement Protocol within ten (10) days of contract execution, to be finalized by DISTRICT within 30 days of contract execution. CONTRACTOR will coordinate collection of annual tax forms (W-9) and provide a paper copy of the 1099's to CSC members in via mail, by January 31 of the following calendar year. CONTRACTOR will send 1099's electronically following CSC members' consent and must be sent in a secure manner such as with file encryption or secure email services. CONTRACTOR's consent process will clearly indicate how the CSC member chooses to access the tax form. CONTRACTOR's distribution of 1099's must comply with IRS and California tax regulations. CSC members will be compensated at a rate of \$75 per hour for pre-approved CERP-related activities and per the CSC charter. CONTRACTOR will collaborate with DISTRICT staff to create a stipend reimbursement form that's approved by DISTRICT and distribute stipends on an invoice and reimbursement basis monthly, processing payment request forms by 2 weeks after each CSC meeting. CONTRACTOR shall make available and shall provide various forms of payment, such as direct deposit, checks, or gift cards and shall be able to make payments of up to \$6,000 per month. Transportation reimbursement will be based on current Internal Revenue Service standard mileage rates, or on actual cost of other forms of transportation, as determined from CSC members providing receipts for other forms of transportation with a cap at \$25 per CSC member per month (the 2026 standard mileage rate is 72 cents per mile). CONTRACTOR will track stipends and reimbursements by 15<sup>th</sup> of each month, provide proof of payment to DISTRICT in monthly invoices, monthly reports on stipend spend down and follow up with CSC members to ensure the processing of payments. CONTRACTOR will also provide an end-of-year summary of stipend disbursements by member by January 31 for past calendar year.
- b) CONTRACTOR will acquire Southeast Community Center (SECC), as available, or another transit-accessible venue for monthly CSC meetings, upon DISTRICT approval of the venue and cost, at least 1 month in advance. For the CSC meetings, CONTRACTOR will procure and provide food and refreshments, including bio-degradable silverware and cups (no plastic). DISTRICT shall provide approval of the catering menu and the quote prior to CONTRACTOR procuring food and refreshments.
- c) CONTRACTOR will print CSC meeting materials (agenda, slides, and handouts) in color, two-sided format. CONTRACTOR will print at least two copies in Spanish and Chinese.

**Deliverables:**

- Provide feedback and suggested revisions on the draft Stipend Disbursement Protocol, including protocol for attendance verification and communications, within ten (10) days of contract execution;
- Collection of W-9's from CSC members;
- 1099's provided to CSC members by January 31 for the past calendar year;
- Stipend reimbursement form;
- Process payment of CSC monthly member stipends, transportation and childcare reimbursements by 2 weeks after each CSC meeting;
- Provide itemized proof of payment to CSC members and update tracking spreadsheet with invoice or by the 15<sup>th</sup> of each month;
- Secure SECC or another DISTRICT-approved venue for in-person meetings, at least 1 month in advance;
- Secure DISTRICT approval of food menu;
- Provide receipts for CSC meeting food and venue;
- Printed CSC meeting materials for 50 participants and at least two copies in Spanish and Chinese;
- Tracking and monitoring of monthly and overall stipend spend down with reports monthly;
- End-of-year summary of stipend disbursements by member and a record of 1099 distribution by January 31 for past calendar year; and
- Invoices and supporting documentation by the end of the month for the previous month.

**ATTACHMENT B-1**

**COST SCHEDULE**

DISTRICT will pay CONTRACTOR on an hourly basis for the services described in Attachment A, Scope of Work, in accordance to Table 1 below. CONTRACTOR will invoice DISTRICT monthly for the hours worked and other direct costs incurred in the prior month. DISTRICT shall pay CONTRACTOR within thirty (30) days following DISTRICT receipt and approval of CONTRACTOR’s invoice. Invoicing and payments will be made in accordance to Section 8, Payment, of this Contract.

**Table 1 - Hourly Rates**

| <b>Name</b>             | <b>Job Title</b>       | <b>Hourly Rate(through 6/30/27)</b> | <b>Hourly Rates 7/1/26-6/30/27</b> | <b>Hourly Rates 7/1/27-6/30/28</b> |
|-------------------------|------------------------|-------------------------------------|------------------------------------|------------------------------------|
| Lauren Weston           | Executive Director     | \$161.87                            | \$169.96                           | \$181.86                           |
| Genevieve Lucas-Conwell | Director of Programs   | \$97.00                             | \$101.85                           | \$108.98                           |
| Zack Wurtz              | Director of Operations | \$86.17                             | \$90.48                            | \$96.81                            |
| TBD                     | Project Senior Manager | \$69.75                             | \$73.24                            | \$78.36                            |
| Michelle Kim            | Operations Manager     | \$54.94                             | \$67.69                            | \$61.63                            |
| TBD                     | Program Associate      | \$48.10                             | \$50.51                            | \$54.04                            |

DISTRICT will pay CONTRACTOR for general direct costs to complete the work described in Attachment A, Scope of Work in accordance to Table 2 below. Direct cost may be reallocated if CONTRACTOR receives written approval from the DISTRICT via email prior to exceeding the amount. Reallocation may not result in the Contract NTE for general direct costs (\$323,449) being exceeded.

**Table 2 - Not to Exceed General Direct Costs**

| <b>Direct Cost Item</b>                      | <b>Cost per Unit</b>           | <b>Cost</b>  |
|--|--------------------------------|--------------|
| Venue for in-person meetings                 | \$1,350                        | \$33,960.00  |
| Refreshments and Food for in-person meetings | \$1,000.00                     | \$26,720.00  |
| Printed Materials                            |                                | \$7,440.00   |
| Stipends                                     | \$75.00                        | \$196,101.00 |
| Childcare Reimbursements                     | \$450.00                       | \$12,400.00  |
| Transportation Reimbursements                | \$125.00                       | \$2,248.00   |
| Acterra Staff Transportation                 |                                | \$2,080.00   |
| Interpretation Equipment                     | CONTRACTOR will supply in-kind | \$0.00       |
| Translation and Interpretation               | Rush Rates:                    | \$41,000.00  |

|  |  |                         |
|--|--|-------------------------|
|  | Same day Turnaround:<br>\$60 additional charge<br>(flat fee)<br>Next day Turnaround:<br>\$50<br>3 days Turnaround:\$40 |                         |
| Zoom Hosting for hybrid meetings (Pay as needed) | Pay per meeting  | <b>Up to \$1,500.00</b> |
|  | Total  | <b>\$323,449.00</b>     |

The following Not to Exceed (NTE) amount in Table 3 describes the anticipated labor cost for each Task. The NTE may be reallocated between tasks if CONTRACTOR receives written approval from the DISTRICT via email prior to exceeding the amount for the task. Reallocation of funds may not result in the Contract NTE for labor costs (\$266,759) being exceeded.

**Table 3 – Not to exceed Labor Costs by Task**

| <b>Task</b> | <b>Description</b>   | <b>Not-to-Exceed Amount</b> |
|-------------|--|-----------------------------|
| 1           | CSC Meeting Planning   | \$137,150.00                |
| 2           | Public CSC Meeting Coordination, Technical Assistance, & Meeting Support | \$48,822.00                 |
| 3           | Reporting  | \$1,840.00                  |
| 4           | Staff Training   | \$2,483.00                  |
| 5           | CSC Meeting Logistics, Stipends and Reimbursements                       | \$76,464.00                 |
|             | Total  | <b>\$266,759.00</b>         |

**Total cost of Contract not to exceed \$590,208.00.**

**BAY AREA AIR DISTRICT**  
Memorandum

To: Chairperson Lynda Hopkins and Members  
of the Board of Directors

From: Alexander G. Crockett  
General Counsel

Date: May 6, 2026

Re: Authorization to Amend Contract with Renne Public Law Group for Legal  
Services Related to Labor and Employment Issues

RECOMMENDED ACTION

Authorize the General Counsel to amend the contract with Renne Public Law Group (RPLG) to increase the maximum dollar amount of the contract by \$1,000,000 – from \$4,050,000 to \$5,050,000 – for legal services related to labor and employment issues, including representation in lawsuits filed by former and current employees; and authorize the transfer of \$250,000 from Outside Counsel Litigation Support Designated Reserves to Program 205 – Litigation to cover the Air District's portion of the litigation costs.

Approximately 75% of the attorneys fees related to the lawsuits are being covered by the Air District's insurance, subject to a reservation of rights. But approximately 25% are not being covered, giving rise to the need for the \$250,000 transfer from designated reserves.

BACKGROUND

The Air District has been working with Renne Public Law Group (RPLG) since June of 2022 to provide expert outside counsel services for advice and counsel in personnel matters and representation in personnel litigation. RPLG is a San Francisco law firm with expertise in public agency personnel issues and has a proven track record of representing agencies like the Air District in these matters.

In the area of advice and counseling, RPLG provides assistance with various employment-related legal matters on an as-needed basis. Attorneys from RPLG provide specialized legal assistance in this area of law in situations where issues arise that may be beyond the expertise of the Air District's in-house attorneys. RPLG attorneys also work directly with the Air District's Human Resources division to provide legal guidance on various issues.

In the area of litigation, RPLG is currently representing the Air District in multiple personnel lawsuits in federal court. RPLG successfully defended the Air District in two of the lawsuits in a consolidated trial in February-March of this year, with a unanimous jury verdict in favor of the Air District on all counts.

The Air District's contract with RPLG (Contract No. 2022.154) has been amended nine times since it was first entered into in June of 2022. The Board of Directors most recently approved an amendment in July of 2025 to bring the total contract limit to \$3,850,000, and in April of 2026 the Air District increased it to its current not-to-exceed contract limit of \$4,050,000 under the authority granted to the General Counsel under Section 9.4(g) of the Administrative Code. RPLG has reached this contract limit, and the Air District therefore needs to amend the agreement to authorize continued work on these matters.

For the litigation matters, **approximately ¾ of these defense costs are being covered by insurance, subject to a reservation of rights. It is therefore unlikely that the Air District will have to pay for all of the \$1,000,000 in work that RPLG is expected to perform under this contract amendment.** However, given the reservation of rights, there is a possibility of a change in position and a denial of coverage. If the Air District were ultimately unable to obtain insurance coverage, it would be required to pay for the full amount of RPLG's work under the agreement. Therefore, out of an abundance of caution and to provide full visibility by the Board into this contract, staff are requesting approval to execute this contract amendment to increase the cost limit by \$1,000,000 to cover anticipated litigation services -- even though we do not expect the Air District will have to pay that amount.

The Air District will be required to pay for the costs of this representation above what is currently being covered by insurance, however. As noted above, the Air District's share of the defense costs is expected to be approximately 25% of total attorneys fees. Staff therefore request that the Board approve the transfer of \$250,000 (25% of \$1,000,000) from Outside Counsel Litigation Support Designated Reserves to Program 205 – Litigation to cover the Air District's portion of the litigation costs.

## DISCUSSION

Section 9.4(g) of the Administrative Code provides that in hiring outside counsel, the General Counsel shall endeavor to follow public agency procurement best practices to the extent practicable under the circumstances, although it does not require strict compliance with the Air District's Procurement Policy. This agreement is consistent with all of the purposes of the Procurement Policy and comports with the requirements of Section 9.4(g) because the Air District conducted a "Request for Qualifications" process (RFQ #2023-035) to pre-qualify outside counsel firms with expertise in multiple areas of law in accordance with Section 8(f) of the Procurement Policy. RPLG submitted a proposal and qualified for several categories, including litigation services related to personnel actions. This agreement was entered into by the District Counsel prior to this

RFQ process, however, so it is technically not covered by the RFQ. The use of RPLG for this work is nevertheless consistent with all the “Procurement Principles” identified in Section 7 of the Procurement Policy. Engaging RPLG is fully compliant with all local, state and federal rules and regulations; RPLG has shown through its work for the Air District to date that it can meet the organization’s needs effectively and efficiently; the firm’s rates compare favorably with the rates of other similar law firms, as demonstrated through the submissions received in the RFQ process, in which RPLG’s rates were among the lowest; the RFQ maintained the fairness and integrity of an open and competitive process, as it publicly advertised the Air District’s solicitation for these services; and it allowed the Air District to review and consider similar firms and ensure that there are no other firms better suited to provide the services required here. Retaining RPLG to perform this work thus furthers all of the purposes for which the Policy was adopted.

In addition, RPLG meets the requirements for a Single-Source procurement under Section 8(e) of the Procurement Policy. RPLG’s knowledge of the underlying circumstances of the litigation makes the firm uniquely qualified for these matters, even if there may be other firms who can represent the Air District in personnel litigation.

RPLG has been highly effective thus far in representing the Air District and has completed substantial legal work both on the pending litigation and on multiple non-litigation matters. It is therefore recommended that RPLG continue representation of the Air District, and that the current agreement with RPLG be amended to increase the limit on fees to allow the firm to perform this work.

BUDGET CONSIDERATION/FINANCIAL IMPACT

Staff anticipate that the Air District may be required to pay up to \$250,000 of the costs associated with litigation under this contract amendment. The Fiscal Year 2025-2026 budget includes \$3,030,000 in remaining designated reserves for outside counsel litigation support. If this item is approved, \$250,000 will be transferred from these designated reserves to amend the Fiscal Year 2025-2026 Legal Division’s program budget and added to Program 205 – Litigation Services to support this contract amendment

Respectfully submitted,

Alexander G. Crockett  
General Counsel

Prepared by: Carrie Schilling  
Reviewed by: Alexander Crockett

ATTACHMENT(S):

1. Renne Public Law 2022.154 Amendment 10\_DRAFT
2. Renne Public Law 2022.154 Amendment 9\_exe
3. Renne Public Law 2022.154 Amendment 8\_exe
4. Renne Public Law 2022.154 Amendment 7\_exe
5. Renne Public Law 2022.154 Amendment 6\_exe
6. Renne Public Law 2022.154 Amendment 5\_exe
7. Renne Public Law 2022.154 Amendment 4\_exe
8. Renne Public Law 2022.154 Amendment 3\_exe
9. Renne Public Law 2022.154 Amendment 2\_exe
10. Renne Public Law 2022.154 Amendment 1\_exe
11. Renne Public Law 2022.154\_exe

April 21, 2026

Via Email – [ACrockett@baaqmd.gov](mailto:ACrockett@baaqmd.gov)>

Alexander Crockett  
General Counsel  
Bay Area Air Quality Management District  
375 Beale Street, Suite 600  
San Francisco, CA 94105

**Re: Legal Services Agreement (General Advice in Labor and Employment)**

Dear Mr. Crockett:

On behalf of Renne Public Law Group, LLP (“RPLG”), we appreciate the opportunity to provide legal services to the Bay Area Air Quality Management District in the area of labor and employment. Per our recent discussions, this letter is to amend our existing Legal Services Agreement dated (for identification purposes only) June 2, 2022, as amended by our subsequent Amendments dated (for identification purposes only) August 29, 2022, September 23, 2022, February 3, 2023, and April 5, 2023, June 7, 2023, November 16, 2023, August 20, 2024, August 5, 2025, and April 1, 2026, to increase the cap on fees from \$4,050,000 to 5,050,000.

By this amendment, the sentence in Section 3 of the Legal Services Agreement that (per the August 29, 2023, September 23, 2022, February 3, 2023, April 5, 2023, June 7, 2023, November 16, 2023, August 20, 2024, August 5, 2025, and April 1, 2026, amendments) reads “Total billed amounts are not to exceed \$4,050,000.00” shall be and is replaced by the following sentence: “Total billed amounts are not to exceed \$5,050,000.00”. All other provisions of the Legal Services Agreement shall remain the same.

Very truly yours,

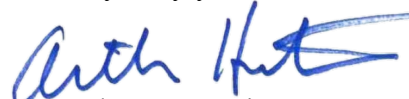
  
Arthur A. Hartinger

cc: RPLG Billing Department

These terms are accepted and agreed to as of the date of this letter.

\_\_\_\_\_  
Alexander Crockett

Alexander Crockett  
General Counsel

Date: \_\_\_\_\_



Arthur A. Hartinger  
[ahartinger@publiclawgroup.com](mailto:ahartinger@publiclawgroup.com)  
(415) 848-7200

April 1, 2026

Via Email – [ACrockett@baaqmd.gov](mailto:ACrockett@baaqmd.gov)>

Alexander Crockett  
General Counsel  
Bay Area Air Quality Management District  
375 Beale Street, Suite 600  
San Francisco, CA 94105

**Re: Legal Services Agreement (General Advice in Labor and Employment)**

Dear Mr. Crockett:

On behalf of Renne Public Law Group, LLP (“RPLG”), we appreciate the opportunity to provide legal services to the Bay Area Air Quality Management District in the area of labor and employment. Per our recent discussions, this letter is to amend our existing Legal Services Agreement dated (for identification purposes only) June 2, 2022, as amended by our subsequent Amendments dated (for identification purposes only) August 29, 2022, September 23, 2022, February 3, 2023, and April 5, 2023, June 7, 2023, November 16, 2023, August 20, 2024, and August 5, 2025 to increase the cap on fees from \$3,850,000 to \$4,050,000.

By this amendment, the sentence in Section 3 of the Legal Services Agreement that (per the August 29, 2023, September 23, 2022, February 3, 2023, April 5, 2023, June 7, 2023, November 16, 2023, August 20, 2024, and August 5, 2025 amendments) reads “Total billed amounts are not to exceed \$3,850,000.00” shall be and is replaced by the following sentence: “Total billed amounts are not to exceed \$4,050,000.00”. All other provisions of the Legal Services Agreement shall remain the same.

Very truly yours,

Arthur A. Hartinger

cc: RPLG Billing Department

These terms are accepted and agreed to as of the date of this letter.

Signed by:  
  
Alexander Crockett  
Alexander Crockett  
General Counsel

Date: 4/29/2026



Arthur A. Hartinger  
[ahartinger@publiclawgroup.com](mailto:ahartinger@publiclawgroup.com)  
(415) 848-72400

June 24, 2025

Via Email – [ACrockett@baaqmd.gov](mailto:ACrockett@baaqmd.gov)>

Alexander Crockett  
General Counsel  
Bay Area Air Quality Management District  
375 Beale Street, Suite 600  
San Francisco, CA 94105

**Re: Legal Services Agreement (General Advice in Labor and Employment)**

Dear Mr. Crockett:

On behalf of Renne Public Law Group, LLP (“RPLG”), we appreciate the opportunity to provide legal services to the Bay Area Air Quality Management District in the area of labor and employment. Per our recent discussions, this letter is to amend our existing Legal Services Agreement dated (for identification purposes only) June 2, 2022, as amended by our subsequent Amendments dated (for identification purposes only) August 29, 2022, September 23, 2022, February 3, 2023, and April 5, 2023, June 7, 2023, November 16, 2023, and August 20, 2024, to increase the cap on fees from \$2,750,000 to \$3,850,000.

By this amendment, the sentence in Section 3 of the Legal Services Agreement that (per the August 29, 2023, September 23, 2022, February 3, 2023, April 5, 2023, June 7, 2023, November 16, 2023, and August 20, 2024, amendments) reads “Total billed amounts are not to exceed \$2,750,000.00” shall be and is replaced by the following sentence: “Total billed amounts are not to exceed \$3,850,000.00”. All other provisions of the Legal Services Agreement shall remain the same.

Very truly yours,

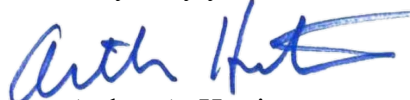
  
Arthur A. Hartinger

cc: RPLG Billing Department

These terms are accepted and agreed to as of the date of this letter.

DocuSigned by: Carrie Schilling for Alexander Crockett  
  
Alexander Crockett  
General Counsel

Date: 8/5/2025



Arthur A. Hartinger  
Partner  
[ahartinger@publiclawgroup.com](mailto:ahartinger@publiclawgroup.com)  
(415) 848-7200

August 20, 2024

Via Email – [ACrockett@baaqmd.gov](mailto:ACrockett@baaqmd.gov)

Alexander Crockett  
General Counsel  
Bay Area Air Quality Management District  
375 Beale Street, Suite 600  
San Francisco, CA 94105

**Re: Legal Services Agreement (General Advice in Labor and Employment)**

Dear Mr. Crockett:

On behalf of Renne Public Law Group, LLP (“RPLG”), we appreciate the opportunity to provide legal services to the Bay Area Air Quality Management District in the area of labor and employment. Per our recent discussions, this letter is to amend our existing Legal Services Agreement dated (for identification purposes only) June 2, 2022, as amended by our subsequent Amendments dated (for identification purposes only) August 29, 2022, September 23, 2022, February 3, 2023, April 5, 2023, June 7, 2023, and November 16, 2023, to increase the cap on fees from \$800,000 to \$2,750,000.

By this amendment, the sentence in Section 3 of the Legal Services Agreement that (per the August 29 and September 23, 2022, and February 3, April 5, June 7, and November 16, 2023, amendments) reads “Total billed amounts are not to exceed \$800,000.00” shall be and is replaced by the following sentence: “Total billed amounts are not to exceed \$2,750,000.00”. All other provisions of the Legal Services Agreement shall remain the same.

Very truly yours,

Arthur A. Hartinger

cc: RPLG Billing Department

These terms are accepted and agreed to as of the date of this letter.

DocuSigned by:  
  
Alexander Crockett  
General Counsel

Date: 10/16/2024



Arthur A. Hartinger  
Partner  
[ahartinger@publiclawgroup.com](mailto:ahartinger@publiclawgroup.com)  
(415) 848-7200

September 25, 2023

Via Email – [ACrockett@baaqmd.gov](mailto:ACrockett@baaqmd.gov)

Philip M. Fine  
Executive Officer/APCO  
Alexander Crockett  
District Counsel  
Bay Area Air Quality Management District  
375 Beale Street, Suite 600  
San Francisco, CA 94105

**Re: Legal Services Agreement (General Advice in Labor and Employment)**

Dear Dr. Fine and Mr. Crockett:

On behalf of Renne Public Law Group, LLP (“RPLG”), we appreciate the opportunity to provide legal services to the Bay Area Air Quality Management District in the area of labor and employment. Per our recent discussions, this letter is to amend our existing Legal Services Agreement dated (for identification purposes only) June 2, 2022, as amended by our subsequent Amendments dated (for identification purposes only) August 29, 2022, September 23, 2022, February 3, 2023, April 5, 2023, and June 7, 2023, to increase the cap on fees from \$550,000 to \$800,000.

By this amendment, the sentence in Section 3 of the Legal Services Agreement that (per the August 29 and September 23, 2022, and February 3, April 5, and June 7, 2023, amendments) that reads “Total billed amounts are not to exceed \$550,000.00” shall be and is replaced by the following sentence: “Total billed amounts are not to exceed \$800,000.00”. All other provisions of the Legal Services Agreement shall remain the same.

Very truly yours,

Arthur A. Hartinger

cc: RPLG Billing Department

These terms are accepted and agreed to as of the date of this letter.

DocuSigned by:  
  
Philip M. Fine  
Executive Officer/APCO

DocuSigned by:  
  
Alexander Crockett  
District Counsel

Date: 11/16/2023

Date: 11/16/2023



Arthur A. Hartinger  
Partner  
[ahartinger@publiclawgroup.com](mailto:ahartinger@publiclawgroup.com)  
(415) 848-7200

May 30, 2023

Via Email – [ACrockett@baaqmd.gov](mailto:ACrockett@baaqmd.gov)

Philip M. Fine  
Executive Officer/APCO  
Alexander Crockett  
District Counsel  
Bay Area Air Quality Management District  
375 Beale Street, Suite 600  
San Francisco, CA 94105

**Re: Legal Services Agreement (General Advice in Labor and Employment)**

Dear Dr. Fine and Mr. Crockett:

On behalf of Renne Public Law Group, LLP (“RPLG”), we appreciate the opportunity to provide legal services to the Bay Area Air Quality Management District in the area of labor and employment. Per our recent discussions, this letter is to amend our existing Legal Services Agreement dated (for identification purposes only) June 2, 2022, as amended by our subsequent Amendments dated (for identification purposes only) August 29, 2022, September 23, 2022, February 3, 2023, and April 5, 2023, to increase the cap on fees from \$400,000 to \$550,000.

By this amendment, the sentence in Section 3 of the Legal Services Agreement that (per the August 29 and September 23, 2022, February 3, 2023, and April 5, 2023, amendments) that reads “Total billed amounts are not to exceed \$400,000.00” shall be and is replaced by the following sentence: “Total billed amounts are not to exceed \$550,000.00”. All other provisions of the Legal Services Agreement shall remain the same.

Very truly yours,

Arthur A. Hartinger

cc: RPLG Billing Department

These terms are accepted and agreed to as of the date of this letter.

DocuSigned by:  
  
7314B577922A46A...  
Philip M. Fine  
Executive Officer/APCO

DocuSigned by:  
  
6DC7110552B5451...  
Alexander Crockett  
District Counsel

Date: 6/27/2023

Date: 6/26/2023



Arthur A. Hartinger  
[ahartinger@publiclawgroup.com](mailto:ahartinger@publiclawgroup.com)  
(415) 848-72400

March 22, 2023

Via Email – [ACrockett@baaqmd.gov](mailto:ACrockett@baaqmd.gov)>

Philip M. Fine  
Executive Officer/APCO  
Alexander Crockett  
District Counsel  
Bay Area Air Quality Management District  
375 Beale Street, Suite 600  
San Francisco, CA 94105

**Re: Legal Services Agreement (General Advice in Labor and Employment)**

Dear Dr. Fine and Mr. Crockett:

On behalf of Renne Public Law Group, LLP (“RPLG”), we appreciate the opportunity to provide legal services to the Bay Area Air Quality Management District in the area of labor and employment. Per our recent discussions, this letter is to amend our existing Legal Services Agreement dated (for identification purposes only) June 2, 2022, as amended by our subsequent Amendments dated (for identification purposes only) August 29, 2022, September 23, 2022, and February 3, 2023, to increase the cap on fees from \$300,000 to \$400,000.

By this amendment, the sentence in Section 3 of the Legal Services Agreement that (per the August 29 and September 23, 2022, and February 3, 2023, amendments) that reads “Total billed amounts are not to exceed \$300,000.00” shall be and is replaced by the following sentence: “Total billed amounts are not to exceed \$400,000.00”. All other provisions of the Legal Services Agreement shall remain the same.

Very truly yours,

Arthur A. Hartinger

cc: RPLG Billing Department

These terms are accepted and agreed to as of the date of this letter.

DocuSigned by:  
  
Philip M. Fine  
Executive Officer/APCO

DocuSigned by:  
  
Alexander Crockett  
District Counsel

Date: 4/17/2023

Date: 4/17/2023



Arthur A. Hartinger  
[ahartinger@publiclawgroup.com](mailto:ahartinger@publiclawgroup.com)  
(415) 848-72400

January 30, 2023

*Via Email – [ACrockett@baaqmd.gov](mailto:ACrockett@baaqmd.gov)>*

Sharon Landers  
Interim Executive Officer/APCO  
Alexander Crockett  
District Counsel  
Bay Area Air Quality Management District  
375 Beale Street, Suite 600  
San Francisco, CA 94105

**Re: Legal Services Agreement (General Advice in Labor and Employment)**

Dear Ms. Landers and Mr. Crockett:

On behalf of Renne Public Law Group, LLP (“RPLG”), we appreciate the opportunity to provide legal services to the Bay Area Air Quality Management District in the area of labor and employment. Per our recent discussions, this letter is to amend our existing Legal Services Agreement dated (for identification purposes only) June 2, 2022, as amended by our subsequent Amendments dated (for identification purposes only) August 29, 2022, and September 23, 2022, to increase the cap on fees from \$200,000 to \$300,000.

By this amendment, the sentence in Section 3 of the Legal Services Agreement that (per the August 29 and September 23, 2022 amendments) reads “Total billed amounts are not to exceed \$200,000.00” shall be and is replaced by the following sentence: “Total billed amounts are not to exceed \$300,000.00”. All other provisions of the Legal Services Agreement shall remain the same.

Very truly yours,

A handwritten signature in blue ink, appearing to read "Arthur Hartinger", with a stylized flourish at the end.

Arthur A. Hartinger

cc: RPLG Billing Department

These terms are accepted and agreed to as of the date of this letter.



DocuSigned by:

*Sharon Landers*

7180203A08BE42D...

Sharon Landers  
Interim Executive Officer/APCO

Date: 2/3/2023

DocuSigned by:

*Alexander Crockett*

B5AE1A26FCA4463

Alexander Crockett  
District Counsel

Date: 2/3/2023



Arthur A. Hartinger  
ahartinger@publiclawgroup.com  
(415) 848-72400

September 23, 2022

Via Email – [ACrockett@baaqmd.gov](mailto:ACrockett@baaqmd.gov)>

Sharon Landers  
Interim Executive Officer/APCO  
Alexander Crockett  
District Counsel  
Bay Area Air Quality Management District  
375 Beale Street, Suite 600  
San Francisco, CA 94105

**Re: Legal Services Agreement (General Advice in Labor and Employment)**

Dear Ms. Landers and Mr. Crockett:

On behalf of Renne Public Law Group, LLP (“RPLG”), we appreciate the opportunity to provide legal services to the Bay Area Air Quality Management District in the area of labor and employment. Per our recent discussions, this letter is to amend our existing Legal Services Agreement dated (for identification purposes only) June 2, 2022, as amended by our subsequent Amendment dated (for identification purposes only) August 29, 2022, to increase the cap on fees from \$95,000 to \$200,000.

By this amendment, the sentence in Section 3 of the Legal Services Agreement that (per the August 29, 2022 amendment) reads “Total billed amounts are not to exceed \$95,000.00” shall be and is replaced by the following sentence: “Total billed amounts are not to exceed \$200,000.00”. All other provisions of the Legal Services Agreement shall remain the same.

Very truly yours,  
  
Arthur A. Hartinger

cc: RPLG Billing Department

These terms are accepted and agreed to as of the date of this letter.

DocuSigned by:  
  
5D7BA58C138D4C0...  
Sharon Landers  
Interim Executive Officer/APCO

DocuSigned by:  
  
B5AE1A26FCA4453...  
Alexander Crockett  
District Counsel

Date: 10/27/2022

Date: 10/27/2022



Arthur A. Hartinger  
[ahartinger@publiclawgroup.com](mailto:ahartinger@publiclawgroup.com)  
(415) 848-72400

August 29, 2022

Via Email – [ACrockett@baaqmd.gov](mailto:ACrockett@baaqmd.gov)

Sharon Landers  
Interim Executive Officer/APCO  
Alexander Crockett  
District Counsel  
Bay Area Air Quality Management District  
375 Beale Street, Suite 600  
San Francisco, CA 94105

**Re: Legal Services Agreement (General Advice in Labor and Employment)**

Dear Ms. Landers and Mr. Crockett:

On behalf of Renne Public Law Group, LLP (“RPLG”), we appreciate the opportunity to provide legal services to the Bay Area Air Quality Management District in the area of labor and employment. Per our recent discussions, this letter is to amend our existing Legal Services Agreement dated (for identification purposes only) June 2, 2022, to increase the cap on fees from \$30,000 to \$95,000.

By this amendment, the sentence in Section 3 of the Legal Services Agreement that reads “Total billed amounts are not to exceed \$30,000.00” shall be and is replaced by the following sentence: “Total billed amounts are not to exceed \$95,000.00”. All other provisions of the Legal Services Agreement shall remain the same.

Very truly yours,

  
Arthur A. Hartinger

cc: RPLG Billing Department

These terms are accepted and agreed to as of the date of this letter.

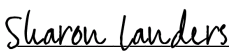
DocuSigned by:  
  
Sharon Landers  
Interim Executive Officer/APCO

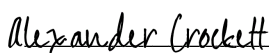
DocuSigned by:  
  
Alexander Crockett  
District Counsel

Date: 9/8/2022

Date: 9/8/2022

**RPLG** Renne Public Law Group®  
350 Sansome Street | Suite 300  
San Francisco, CA 94104

Arthur A. Hartinger  
[ahartinger@publiclawgroup.com](mailto:ahartinger@publiclawgroup.com)  
(415) 848-72400

June 3, 2022

Via Email – [ACrockett@baaqmd.gov](mailto:ACrockett@baaqmd.gov)>

Alexander Crockett  
Chief Attorney  
Bay Area Air Quality Management District  
375 Beale Street, Suite 600  
San Francisco, CA 94105

**Re: Legal Services Agreement (General Advice in Labor and Employment)**

Dear Mr. Crockett:

Thank you for retaining Renne Public Law Group, LLP (“RPLG”) to provide legal services on behalf of Bay Area Air Quality Management District. We appreciate the opportunity to serve as your lawyers and look forward to working with you on this matter.

This Legal Services Agreement (“Agreement”) sets forth our agreement concerning the legal services we will provide and our fee and expense reimbursement arrangements for those services. Please read the entire Agreement before signing and returning it to us.

**1. Scope of Engagement.** We will provide general advice, representation in administrative proceedings, and other legal work in the area of labor and employment. Our work is limited to such services. When we agree to provide legal services in discrete matters, we will confirm the engagement and bill separately for such services.

**2. Fees and Personnel.** As compensation for our services, my hourly fee will be \$450.00, and our overall current public sector rates are attached as Attachment A.

I will be the attorney in charge of your matter[s]. However, this agreement retains the legal services of our law firm and not of a particular attorney. If other attorneys and/or paralegals are assigned to work on your matter, then current hourly rates of those individuals will be utilized. (See Attachment A.).

Rates will generally be increased annually on January 1 by the greater of 3% or the relevant local CPI increase over the prior 12-month period, rounded to the nearest \$5.

In the unlikely event of a dispute over fees, the parties agree that the dispute will be submitted to arbitration pursuant to the State Bar’s Mandatory Fee Arbitration Program.

**3. Billing and Payment Responsibilities.** We will send monthly statements which are due within 30 days of receipt. If you have any questions about an invoice, please promptly



Legal Services Agreement  
Page 2

telephone or write me so that we may discuss these matters. Billing is done in 1/10ths of an hour increments. Total billed amounts are not to exceed \$30,000.00.

Our Statement of Fee and Billing Information, which sets forth the details of our disbursement and expense policy, is attached as ATTACHMENT B.

**4. Termination of Services.** You may terminate RPLG's services at any time by written notice. After receiving such notice, we will cease providing services. We will cooperate with you in the orderly transfer of all related files and records to your new counsel.

RPLG may terminate its services for any reason upon reasonable written notice, consistent with the Rules of Professional Responsibility. If we terminate our services, you agree to execute a substitution of attorneys promptly and otherwise cooperate in effecting that termination.

Termination of our services, whether by you or by us, will not relieve the obligation to pay for services rendered and costs incurred before our services formally ceased.

**5. No Guarantee of Outcome.** Any comments made by us about the potential outcome of this matter are expressions of opinion only and are not guarantees or promises about any outcome or results.

**6. Government Law.** This Agreement shall be governed by and construed in accordance with the laws of the State of California as applicable.

**7. Entire Agreement; Full Understanding; Modifications in Writing.** This letter contains our entire agreement about our representation. Any modifications or additions to this Agreement must be made in writing.

**8. Joint Representation.** Our firm maintains Of Counsel agreements with certain legal specialists. Because these individuals are deemed independent contractors under the applicable provisions of the tax laws and not employees of the firm, it is necessary that you consent to dual representation by the firm and the specialist in the event the matter which you have engaged us to handle requires the use of that specialist. This arrangement has no effect whatsoever on the cost of your legal services, rather it is an ethical requirement that we disclose this fact and that you consent. You are consenting by signing this letter.

Very truly yours,

DocuSigned by:  
  
2D5F3B657D5F429...  
Arthur A. Hartinger



Legal Services Agreement  
Page 3

Attachments: **Public Sector Fee Schedule**  
Statement of Fee and Billing Information

cc: RPLG Billing Department

These terms are accepted and agreed to as of the date of this letter.

By:   
DocuSigned by:  
B5AE1A26FCA4453...

Print Name: Alexander Crockett

Title: District Counsel

By:   
DocuSigned by:  
522CD4246A5149B...

Print Name: Sharon Landers

Title: Interim Executive Officer

## ATTACHMENT A

### **PUBLIC SECTOR FEE SCHEDULE EFFECTIVE JANUARY 1, 2022 TO DECEMBER 31, 2022**

|              |               |
|--------------|---------------|
| Partners:    | \$395- \$500  |
| Of Counsel:  | \$350 - \$450 |
| Associates:  | \$295 - \$350 |
| Law Clerks:  | \$195 - \$295 |
| Paralegals:  | \$145 - \$225 |
| Analysts:    | \$125 - \$275 |
| Consultants: | \$195 - \$475 |

Our rates adjust every January by the greater of 3% or the relevant local CPI increase over the prior 12-month period, rounded to the nearest \$5.



## ATTACHMENT B

### STATEMENT OF FEE AND BILLING INFORMATION

The following is a general description of our fee and billing policies. These general policies may be modified by the specific engagement letter or agreement to which this summary is attached.

**Professional Fees.** Our fees for professional services are based on the fair value of the services rendered. To help us determine the value of our services, our attorneys and paralegals maintain time records for each client and matter. Our attorneys and paralegals are assigned hourly rates which are based on years of experience, specialization, training and level of professional attainment. We adjust our rates periodically (usually at the beginning of each year) to take into account inflation and the increased experience of our professional personnel.

To keep professional fees at a minimum, legal work that does not require more experienced attorneys will be performed, where feasible, by attorneys with lower billing rates. Of course, the quality of the work is paramount, and we do not sacrifice quality to economy.

Before undertaking a particular assignment, we will, if requested, provide you with a fee estimate to the extent possible. Estimates are not possible for some matters, however, and cannot be relied on in many others because the scope of our work will not be clear at the outset. When a fee estimate is given, it is only an estimate; it is not a maximum or minimum fee quotation. The actual fee may be more or less than the quoted estimate.

**Billing and Payment Procedures.** Unless other arrangements are made at the time of the engagement, invoices will be sent monthly. Invoices for outside services exceeding \$100 may be billed separately. Occasionally, however, we may defer billing for a given month or months if the accrued fees and costs do not warrant current billing or if other circumstances would make it appropriate to defer billing.

Our invoices contain a brief narrative description of the work performed; if requested, the initials of the attorney who performed the work will appear on the statement. The invoice will include a line item reflecting in-house administrative costs. The firm's in-house administrative costs include duplicating, facsimile charges, telephone charges, e-mail, postage, mileage and other administrative expenses.

In addition, RPLG charges separately for certain costs incurred in the representation, as well as for any disbursements to third parties made on a client's behalf. Such costs and disbursements include, for example, the following: travel (at the IRS rate in effect at the time the travel occurs), computer-assisted research, transcription, overnight delivery and messenger services. For major disbursements to third parties, invoices may be sent directly to you for payment. RPLG also bills for time spent traveling on a client's behalf at our normal hourly rates.



If you have any questions regarding an invoice, the Operations Manager is available to answer your questions. For any unresolved matters, the Bar Association has an arbitration mechanism that can be used to resolve such matters.

**BAY AREA AIR DISTRICT**  
Memorandum

To: Chairperson Lynda Hopkins and Members  
of the Board of Directors

From: Philip M. Fine  
Executive Officer/APCO

Date: May 6, 2026

Re: Authorization to Execute a Sponsorship Contract with the San Francisco  
Pride Parade

RECOMMENDED ACTION

Authorize the Executive Officer/APCO to execute a sponsorship contract with the San Francisco Pride Parade in an amount not to exceed \$45,000.

BACKGROUND

The San Francisco Pride Parade brings together a broad and diverse mix of Bay Area residents, celebrating LGBTQ+ culture and history. As a sponsor of the San Francisco Pride parade, the Air District will have the opportunity to participate in the parade and highlight the Air District's commitment to the communities we serve, while also elevating the Spare the Air program as a key program for protecting public health and improving air quality. Our presence in the parade reinforces the connection between community education and promoting actions residents can take to reduce pollution and contribute to cleaner, healthier air for all.

As part of our sponsorship policy to ensure adherence to transparency and accountability standards, we are requesting Board approval for the \$45,000 sponsorship to ensure the sponsorship aligns with agency priorities, provides clear public benefit, and meets transparency and fiscal accountability requirements.

DISCUSSION

The Air District's participation in the San Francisco Pride Parade provides a high-visibility platform to promote the Air District and its Spare the Air program to a broad and diverse audience. With over half a million attendees, San Francisco Pride is one of the largest public events in the Bay Area.

Sponsorship benefits include the prominent display of the Air District's logo in event materials, participation in the parade and opportunities for Air District staff to represent the Air District in a meaningful and inclusive setting.

In addition to these tangible outreach and branding benefits, the Air District's involvement in SF Pride reaffirms our commitment to equity and inclusion. At a time when some organizations have withdrawn support for LGBTQ+ events, our continued sponsorship sends a clear message that the Air District values all communities and remains dedicated to serving the public equitably.

BUDGET CONSIDERATION/FINANCIAL IMPACT

Funding for this event sponsorship contract is included in program account 306 from the Fiscal Year Ending 2026 budget.

Respectfully submitted,

Philip M. Fine  
Executive Officer/APCO

Prepared by: Kristina Chu and Isabel Porras  
Reviewed by: Kristine Roselius and Tim Williams

ATTACHMENT(S):

1. Draft Contract San Francisco Pride Parade 2026.058

**BAY AREA AIR QUALITY MANAGEMENT DISTRICT**

**SPONSORSHIP AGREEMENT**

**AGREEMENT NO. 2026.058**

**1. PARTIES**

The parties to this Sponsorship Agreement (Agreement) are the Bay Area Air Quality Management District (DISTRICT), whose address is 375 Beale Street, Suite 600, San Francisco, CA 94105; and **San Francisco LGBT Pride Celebration Committee, Inc.** (SF Pride), whose address is 1663 Mission Street, Suite 305, San Francisco, CA 94103.

**2. RECITALS**

- A. DISTRICT is the regional agency with primary responsibility for regulating stationary source air pollution in the San Francisco Bay Area in the State of California. DISTRICT is authorized to enter into this Agreement under California Health and Safety Code Section 40701.
- B. SF Pride is a 501(c)(3) non-profit organization dedicated to educating the community of LGBTQ+ heritage, culture, and liberation by maintaining principles of inclusion and accessibility. SF Pride seeks DISTRICT sponsorship of its **San Francisco LGBT Pride Celebration & Parade** (Event) on June 27, 2026, to June 28, 2026.
- C. DISTRICT seeks to enhance awareness of its commitment to achieving clean air to protect the public's health and the environment. As such, DISTRICT desires to acquire from SF Pride certain advertising and promotional benefits as described herein, and SF Pride desires to provide such benefits to DISTRICT in exchange for DISTRICT sponsorship of the Event in accordance with the terms and provisions of this Agreement.

**3. TERM**

The term of this Agreement shall be from the date of Agreement execution to June 29, 2026 (Term), unless terminated earlier as provided herewith.

**4. TERMINATION**

Either party may terminate this Agreement upon cancellation of the Event. In the event of such termination, SF Pride shall refund to DISTRICT any and all payments made by DISTRICT pursuant to this Agreement.

**5. ADVERTISING AND PROMOTION**

SF Pride will provide to DISTRICT the advertising and promotional benefits relating to the Event as described in Attachment A attached hereto.

## **6. FEES AND PAYMENT SCHEDULE**

In consideration for SF Pride providing to DISTRICT the advertising and promotional benefits as described in Attachment A, DISTRICT shall sponsor the Event by paying SF Pride the amounts described in Attachment B hereto according to the payment schedule described in Attachment B hereto.

## **7. NON-EXCLUSIVITY**

DISTRICT expressly acknowledges that SF Pride may have other sponsors whose advertising or brands are displayed in connection with SF Pride activities sponsored by DISTRICT. DISTRICT expressly agrees that it is not granted any exclusive rights that would in any manner limit the rights of SF Pride to seek other sponsors and to display advertising or brands of those sponsors, except as may be expressly set forth in Attachment A hereto. To the extent that any right of exclusivity has been granted, the express terms of that right are described in Attachment A hereto.

## **8. DELIVERY OF PROMOTIONAL MATERIALS**

DISTRICT shall be responsible for delivering its promotional materials to SF Pride prior to the publication deadline for each SF Pride publication in which such materials will be published, as long as SF Pride has provided written notice of the publication deadline to DISTRICT.

## **9. PARTIES' TRADEMARKS**

Each party shall be entitled, from time to time, to make reasonable use of the other party's name, trade name, trademarks and logos in connection with advertising or promotional materials; provided, however, that a party shall do so only with the prior written approval of the other party, which approval shall not be unreasonably withheld.

## **10. INDEMNIFICATION**

A. SF Pride shall indemnify and hold harmless DISTRICT, and DISTRICT's officers, employees and agents, from and against any and all liability, loss, expense (including reasonable attorneys' fees), or claims for injury or damages, arising out of the performance of this Agreement; but only in proportion to and to the extent such liability, loss, expense (including reasonable attorneys' fees), or claims for injury or damages are caused by or result from the negligent or intentional acts or omissions of SF Pride or its officers, agents, or employees. This provision shall survive the expiration or termination of this Agreement.

## **11. INSURANCE**

- A. SF Pride shall maintain the following Event Insurance:
- i. Workers' compensation and employers' liability insurance as required by California law or other applicable statutory requirements for any persons employed by SF Pride for the Event.
  - ii. Occurrence-based commercial general liability insurance or equivalent form with a limit of not less than one million dollars (\$1,000,000) each occurrence. Such insurance shall include

DISTRICT and its officers, agents, and employees as additional insureds for the Event and shall be primary with respect to any insurance maintained by DISTRICT.

iii. Business automobile liability insurance or equivalent form with a limit of not less than one million dollars (\$1,000,000) each accident covering each automobile used by SF Pride in connection with the Event. Such insurance shall include coverage for owned, hired, and non-owned vehicles.

B. Prior to the Event, SF Pride shall furnish properly-executed certificates of insurance for all required insurance. SF Pride shall notify DISTRICT in writing fifteen (15) days prior to cancellation or modification of any required insurance policy. Any such modifications are subject to pre-approval by DISTRICT.

## 12. NOTICES

All notices that are required under this Agreement shall be provided in the manner set forth herein, unless specified otherwise. Notice to a party shall be delivered to the attention of the person listed below, or to such other person or persons as may hereafter be designated by that party in writing. Notice shall be in writing sent by e-mail, facsimile, or regular first class mail. In the case of e-mail and facsimile communications, valid notice shall be deemed to have been delivered upon sending, provided the sender obtained an electronic confirmation of delivery. E-mail and facsimile communications shall be deemed to have been received on the date of such transmission, provided such date was a business day and delivered prior to 4:00 p.m. Pacific Time. Otherwise, receipt of e-mail and facsimile communications shall be deemed to have occurred on the following business day. In the case of regular mail notice, notice shall be deemed to have been delivered on the mailing date and received five (5) business days after the date of mailing.

DISTRICT:

Bay Area Air Quality Management District

375 Beale Street, Suite 600

San Francisco, CA 94105

Attn: Matthias Shiber

SF Pride:

San Francisco LGBT Pride Celebration Committee,  
Inc.

1663 Mission Street, Suite 305

San Francisco, CA 94103

Attn: Suzanne Ford

**13. ADDITIONAL PROVISIONS**

All attachment(s) to this Agreement are expressly incorporated herein by this reference and made a part hereof as though fully set forth.

**14. AUDIT / INSPECTION OF RECORDS**

If this Agreement exceeds \$10,000, pursuant to California Government Code Section 8546.7, all records, documents, conditions and activities of San Francisco LGBT Pride Celebration Committee, Inc., and its subcontractors, related to the services provided hereunder, shall be subject to the examination and audit of the California State Auditor and other duly authorized agents of the State of California for a period of three (3) years after final payment under this Agreement. San Francisco LGBT Pride Celebration Committee, Inc. hereby agrees to make such records available during normal business hours for inspection, audit, and reproduction by any duly authorized agents of the State of California or DISTRICT. San Francisco LGBT Pride Celebration Committee, Inc. further agrees to allow interviews of any of its employees who might reasonably have information related to such records by any duly authorized agents of the State of California or DISTRICT. All examinations and audits conducted under this section shall be strictly confined to those matters connected with the performance of this Agreement, including, but not limited to, the costs of administering this Agreement.

**15. RELATIONSHIP OF THE PARTIES**

Nothing contained herein shall imply any partnership, joint venture or agency relationship between the parties and neither party shall have the power to obligate or bind the other in any manner whatsoever, except to the extent herein provided.

**16. ASSIGNMENT**

No party shall assign, sell, license, or otherwise transfer any rights or obligations under this Agreement to a third party without the prior written consent of the other party, and any attempt to do so shall be void upon inception.

**17. WAIVER**

No waiver of a breach, of failure of any condition, or of any right or remedy contained in or granted by the provisions of this Agreement shall be effective unless it is in writing and signed by the party waiving the breach, failure, right, or remedy. No waiver of any breach, failure, right, or remedy shall be deemed a waiver of any other breach, whether or not similar, nor shall any waiver constitute a continuing waiver unless the writing so specifies. Further, the failure of a party to enforce performance by the other party of any term, covenant, or condition of this Agreement, and the failure of a party to exercise any rights or remedies hereunder, shall not be deemed a waiver or relinquishment by that party to enforce future performance of any such terms, covenants, or conditions, or to exercise any future rights or remedies.

**18. FORCE MAJEURE**

Neither DISTRICT nor SF Pride shall be liable for or deemed to be in default for any delay or failure in performance under this Agreement or interruption of services resulting, directly or indirectly, from acts

of God, enemy or hostile governmental action, civil commotion, strikes, lockouts, labor disputes, fire or other casualty, judicial orders, governmental controls, regulations or restrictions, inability to obtain labor or materials or reasonable substitutes for labor or materials necessary for performance of the services, or other causes, except financial, that are beyond the reasonable control of DISTRICT or SF Pride, for a period of time equal to the period of such force majeure event, provided that the party failing to perform notifies the other party within fifteen calendar days of discovery of the force majeure event, and provided further that that party takes all reasonable action to mitigate the damages resulting from the failure to perform. Notwithstanding the above, if the cause of the force majeure event is due to party's own action or inaction, then such cause shall not excuse that party from performance under this Agreement.

**19. SEVERABILITY**

If a court of competent jurisdiction holds any provision of this Agreement to be illegal, unenforceable or invalid in whole or in part for any reason, the validity and enforceability of the remaining provisions, or portions of them will not be affected.

**20. HEADINGS**

Headings on the sections and paragraphs of this Agreement are for convenience and reference only, and the words contained therein shall in no way be held to explain, modify, amplify, or aid in the interpretation, construction, or meaning of, the provisions of this Agreement.

**21. DUPLICATE EXECUTION**

This Agreement may be executed in separate, duplicate counterparts. Each signed counterpart shall have the force and effect of an original, and all such counterparts together shall constitute one and the same instrument.

**22. GOVERNING LAW**

Any dispute that arises under or relates to this Agreement shall be governed by California law, excluding any laws that direct the application to another jurisdiction's laws. Venue for resolution of any dispute that arises under or relates to this Agreement, including mediation, shall be San Francisco, California.

**23. ATTORNEYS' FEES**

In the event any action is filed in connection with the enforcement or interpretation of this Agreement, each party shall bear its own attorneys' fees and costs.

**24. ENTIRE AGREEMENT AND MODIFICATION**

This Agreement represents the final, complete, and exclusive statement of the agreement between the parties, and it supersedes all prior and contemporaneous understandings and agreements of the parties. No party has been induced to enter into this Agreement by, nor is any party relying upon, any representation or warranty outside those expressly set forth herein. This Agreement may be amended only by mutual agreement of the parties in writing and signed by both parties.

IN WITNESS WHEREOF, the parties to this Agreement have caused this Agreement to be duly executed on their behalf by their authorized representatives.

BAY AREA AIR QUALITY  
MANAGEMENT DISTRICT

SAN FRANCISCO LGBT PRIDE  
CELEBRATION COMMITTEE, INC.

By: \_\_\_\_\_  
Dr. Philip M. Fine  
Executive Officer

By: \_\_\_\_\_  
Suzanne Ford  
Executive Director

Date: \_\_\_\_\_

Date: \_\_\_\_\_

By: \_\_\_\_\_  
Joshua Smith  
President

Date: \_\_\_\_\_

Approved as to form:

By: \_\_\_\_\_  
Alexander G. Crockett  
General Counsel

## Attachment A

### DISTRICT'S ADVERTISING AND PROMOTIONAL BENEFITS

In exchange for DISTRICT'S sponsorship of the Event, SF Pride will provide DISTRICT the following benefits:

- A. Recognition of DISTRICT as a Sponsor of the 2026 SF Pride Celebration & Parade.
- B. Provision of a 10'x10' booth at Civic Center Plaza Celebration.
- C. Parade contingent with up to 1000 marchers and 2 vehicles, subject to the parade rules and regulations.
- D. Priority parade lineup placement ahead of non-sponsor corporate contingents.
- E. Media & Advertising:
  - i. Inclusion in "sponsor grid" thanking all sponsors, appearing in multiple locations.
  - ii. Parade route banner ad placement of DISTRICT-provided 8'x3' banners.
  - iii. Print ("Inside Pride" Guide).
  - iv. Placement of DISTRICT Logo in sponsor grid.
  - v. Quarter-page ad.
- F. Digital:
  - i. Placement of DISTRICT Logo on [sfpride.org/sponsors](https://sfpride.org/sponsors).
  - ii. DISTRICT Logo inclusion in SF Pride newsletter.
- G. Hospitality & Tickets:
  - i. 4 tickets to "Heritage of Pride" Awards (June 24, 2026).
  - ii. 4 tickets for SF Pride Parade Grandstands.

## Attachment B

### Sponsorship Fee and Payment Schedule

DISTRICT shall pay SF Pride the amount of \$45,000.00 to sponsor the Event. Payment shall be made within thirty (30) days following execution of this Agreement and submission of an invoice by SF Pride.

**Total Cost of Agreement Not to Exceed: \$45,000.00.**

DRAFT

**BAY AREA AIR DISTRICT**  
Memorandum

To: Chairperson Lynda Hopkins and Members  
of the Board of Directors

From: Philip M. Fine  
Executive Officer/APCO

Date: May 6, 2026

Re: Transportation Fund for Clean Air 40% Fund Allocation and Expenditure  
Plans for Fiscal Year Ending 2027

RECOMMENDED ACTION

1. Approve the proposed allocation and expenditure plans for the estimated new Transportation Fund for Clean Air revenue to each of the nine Administering Agencies for Fiscal Year Ending 2027 that will be funded by the 40% portion of the Transportation Fund for Clean Air;
2. Approve the proposed allocation of additional funding for bikeway and bike parking projects to each of the nine Administering Agencies for Fiscal Year Ending 2027 that will be funded by prior years' revenue under the 60% portion of Transportation Fund for Clean Air fund; and
3. Authorize the Executive Officer/APCO to enter into funding agreements with the Administering Agencies for Transportation Fund for Clean Air revenues to be programmed in Fiscal Year End 2027.

The Policy, Grants, and Technology Committee recommended this item at its meeting on April 15, 2026.

BACKGROUND

In 1991, the California State Legislature authorized the California Department of Motor Vehicles (DMV) to impose a \$4 surcharge on motor vehicles registered within the nine-county Bay Area to fund projects that reduce on-road motor vehicle emissions within the Bay Area Air District's jurisdiction. The legislative requirements that enable the use of the funds are codified in California Health and Safety Code (HSC) Sections 44241 through 44242.

Forty percent of new Transportation Fund for Clean Air (TFCA) revenue is passed through to the designated Administering Agency in each of the nine counties within the Air District's jurisdiction based on each county's proportionate share of vehicle

registration fees collected. As these are pass-through funds, the county Administering Agencies have discretion over these funds within the bounds set by the TFCA authorizing legislation. The authorizing legislation requires that the Administering Agencies hold one or more public meetings to adopt criteria for the expenditure of funds and a separate meeting to review expenditures. The Air District's role is to facilitate the process to ensure that the funds are used for eligible cost-effective reductions of on-road emissions, to pass-through the funds, and later to coordinate an audit of funds expended.

The Air District awards the remaining sixty percent to eligible projects and programs it implements directly via the TFCA 60% Fund. Monies from projects funded by the 60% Fund that fall out or come in under budget are returned to the Air District for reallocation. These funds are held in an interest-bearing account.

In 2023, Air District staff engaged the Mobile Source and Climate Impacts Committee (predecessor to the Policy, Grants, and Technology Committee) in an open discussion as to how to best utilize TFCA funds. There were several key pieces of feedback that came out of that discussion and subsequent Committee meetings directing Air District staff to propose opportunities that utilize the TFCA funds for cost-effective programs like the Vehicle Buy Back Program, zero-emission technologies such as electric trucks and buses, and long-lasting infrastructure with public health impacts such as bikeways.

In response to this feedback, Air District staff initiated changes to the Vehicle Buy Back Program to create greater interest and opened several zero-emission heavy-duty truck and bus solicitations. Air District staff also considered several options for utilizing TFCA funding for bike projects and ultimately determined that the Counties were the best administrators for this type of program. Counties already have plans for bikeways and bike infrastructure, are familiar with the landscape and need, and are in ongoing community conversations about where to prioritize their bikeway funds. This aligns with the Air District's Strategic Plan goal of building trusting partnerships in which the community is directing the use of funds to reduce emissions impacts locally.

The Air District can allocate additional pass-through funding from its TFCA 60% Fund that accumulated from previous years' projects that had come in under budget or fell-out during the pandemic. In addition, high interest rates have increased this pool of funds, making them a viable source to allocate towards the Counties' implementation of bike projects.

The Air District determined that adding these funds to a County's annual allocation via their expenditure plans was the most straightforward way to passthrough, track, and account for these funds. Like other TFCA projects, projects funded with this additional bike funding allocation will follow the TFCA policies and cost-effectiveness limits adopted by the Air District Board of Directors.

Pursuant to HSC Section 44241, Administering Agencies must award TFCA funds to eligible projects within six months of the Air District Board of Directors' approval of their

expenditure plans. This is inclusive of the additional bikeway and bike parking funding. Annually, Administering Agencies submit expenditure plans to the Air District specifying the status of their prior-year funding that is available for reprogramming and interest accrued. The Board of Directors adopted the policies and cost-effectiveness criteria for expenditure of the TFCA 40% Fund commencing Fiscal Year Ending (FYE) 2027 on December 3, 2025.

**DISCUSSION**

The recommended allocation for the nine Bay Area counties totals approximately \$32.6 million. This includes \$9.5 million in passthrough DMV fee revenues based on each County’s share of registered vehicles, plus \$3.8 million in reprogrammed funds from prior-year project fall-out and reconciliation.

It is also recommended that the Counties receive a total of \$16.5 million for bikeway and bike parking projects. This includes a \$1 million base allocation for each County, plus additional funds based on each County’s share of fee-paid vehicle registrations. Counties with Assembly Bill (AB) 617 communities are recommended to receive an additional \$2.8 million total, consisting of a \$500,000 base amount plus a proportional share tied to vehicle registration fees.

The Air District received the proposed expenditure plans from all nine Administering Agencies. Table 1 shows the TFCA monies that are estimated to be available to the Administering Agencies in FYE 2027, based on their submitted expenditure plans.

**Table 1. Proposed Allocation and Planned Expenditures for FYE 2027**

|   | <b>TFCA 40% Fund Allocation</b>   |   | <b>TFCA 60% Additional Allocation</b> |   |  |
|---|-----------------------------------|---|---------------------------------------|---|--|
| <b>Administering Agency</b>                     | <b>Estimated New TFCA Revenue</b> | <b>Reconciliation &amp; Reprogrammed TFCA Funds</b> | <b>Bikeway Funding Allocation</b>     | <b>Additional AB 617 Bikeway Funding Allocation</b> | <b>Estimated Total FYE 2027 TFCA Funds</b> |
| <b>Alameda County Transportation Commission</b> | \$1,990,945                       | \$2,452,097   | \$3,127,500                           | \$1,215,000   | \$8,821,542                                |
| <b>Contra Costa Transportation Authority</b>    | \$1,593,438                       | \$584,000   | \$2,539,500                           | \$1,015,800   | \$5,732,738                                |
| <b>Transportation Authority of Marin</b>        | \$363,508                         | \$44,816  | \$1,000,000                           | -   | \$1,408,324                                |

|   |             |             |              |             |              |
|---|-------------|-------------|--------------|-------------|--------------|
| <b>Napa Valley Transportation Authority</b>             | \$205,390   | \$76,587    | \$1,000,000  | -           | \$1,281,977  |
| <b>San Francisco County Transportation Authority</b>    | \$711,289   | \$169,628   | \$1,116,000  | \$500,000   | \$2,496,917  |
| <b>San Mateo City/County Association of Governments</b> | \$1,080,294 | \$195,300   | \$1,755,000  | -           | \$3,030,594  |
| <b>Santa Clara Valley Transportation Authority</b>      | \$2,521,887 | \$186,133   | \$3,970,500  | -           | \$6,678,520  |
| <b>Solano Transportation Authority</b>                  | \$346,168   | \$11,564    | \$1,000,000  | -           | \$1,357,732  |
| <b>Sonoma County Transportation Authority</b>           | \$656,114   | \$89,524    | \$1,041,000  | -           | \$1,786,638  |
| <b>Total Allocation</b>                                 | \$9,469,033 | \$3,809,649 | \$16,549,500 | \$2,766,800 | \$32,594,982 |

\*Numbers may differ by one dollar from expenditure plans submitted by the Counties due to rounding.

#### BUDGET CONSIDERATION/FINANCIAL IMPACT

TFCA revenue is generated from DMV registration fees collected and 40% of the TFCA funds are passed through to the Administering Agencies. The Air District awards the remaining 60% to eligible projects and programs it implements directly (e.g., Spare the Air) and to the TFCA Regional Fund program. Funds from projects that fall-out or come in under budget from that 60% are collected in an interest-bearing account and available for reallocation to other projects, including as passthrough funds to Administering Agencies. Administrative costs for the Administering Agencies and the Air District are reimbursed by TFCA program revenue.

Respectfully submitted,

Philip M. Fine  
Executive Officer/APCO

Prepared by: Jason Newman  
Reviewed by: Kenneth Mak, Minda Berbeco, and Alona Davis

ATTACHMENT(S):

None

**BAY AREA AIR DISTRICT**  
Memorandum

To: Chairperson Lynda Hopkins and Members  
of the Board of Directors

From: Philip M. Fine  
Executive Officer/APCO

Date: May 6, 2026

Re: Consideration of State Legislation

**RECOMMENDED ACTION**

Adopt positions on pending state legislative bills where appropriate, including, but not limited to the following bills:

As recommended by the Policy, Grants, and Technology Committee at its meeting on April 15, 2026:

**SUPPORT**

Assembly Bill 2349 (Solache)  
Senate Bill 1159 (Cabaldon)

**OPPOSE**

Assembly Bill 2057 (DeMaio)  
Assembly Bill 2102 (DeMaio)  
Senate Bill 1039 (Grove)  
Senate Bill 1075 (Reyes)

As recommended by Air District staff based on amended bill language:

**OPPOSE UNLESS AMENDED**

Senate Bill 1075 (Reyes)

**BACKGROUND**

The Policy, Grants, and Technology Committee (Committee) met on April 15, 2026, to discuss and consider Air District staff recommendations for six (6) bills – Assembly Bill (AB) 2057 (DeMaio), AB 2102 (DeMaio), AB 2349 (Solache), Senate Bill (SB) 1039 (Grove), SB 1075 (Reyes), and SB 1159 (Cabaldon). The Committee recommended that the Board of Directors adopt the Air District staff recommendations for all the identified bills.

After the Committee met on April 15, 2026, SB 1075 (Reyes) was amended and Air District staff is recommending an "Oppose Unless Amended" position for the Board's consideration.

## DISCUSSION

The Board will consider adopting positions on pending state legislative bills where appropriate, including, but not limited to the following bills, as presented to the Policy, Grants, and Technology Committee on April 15, 2026. The Committee recommended that the Board of Directors adopt the Air District staff recommendations for all the identified bills. In addition, there are noted updates below for AB 2057 (DeMaio), AB 2102 (DeMaio), and SB 1075 (Reyes).

- [AB 2057 \(DeMaio\)](#) – *Natural Gas: Appliances*

This bill would prohibit a state agency or local government from adopting or enforcing a rule, regulation, resolution, or ordinance that directly or indirectly results in prohibiting the use of gas appliances in residential or nonresidential buildings.

Air District staff recommends opposing this bill because it would likely retroactively apply to recent Air District heater rules.

Committee Recommendation: Oppose

Staff Note: This did not meet the deadline to pass out of its referred policy committees and is dead.

- [AB 2102 \(DeMaio\)](#) – *Wildfire: Vegetation Management: Fuel Reduction Activities*

This bill would vest all wildfire fuel reduction activities, including prescribed fire, to a local fire department or CalFire. Additionally, the bill would prohibit the California Air Resources Board (CARB) from imposing various conditions on fuel reduction activities (including prescribed fires).

Air District staff recommends opposing this bill because prohibiting CARB from participating in the prescribed fire program would likely restrict an air district's ability to permit and allow burning on days that are best for air quality considerations.

Committee Recommendation: Oppose

Staff Note: This did not meet the deadline to pass out of its referred policy committees and is dead.

- [AB 2349 \(Solache\)](#) – *State Air Resources Board: Regional Air Quality Incident Response Program*

This bill would require CARB to expand its incident air monitoring program, subject to an appropriation by the Legislature for, to provide support for a

regional network of air quality incident response centers, including at least one air quality incident response and evaluation center located at the South Coast Air Quality Management District, in order to facilitate emergency air monitoring response at the local and regional level. The bill would require each air quality incident response center to be operated by CARB or an air district and would require CARB and each district that operates an air quality incident response center to coordinate to provide emergency air monitoring response for disasters or other crises impacting air quality and public health in the state. The bill would provide that funding made available by the Legislature for purposes of these provisions may be used for various purposes, including program funding to plan, create, equip, and maintain air quality incident response centers.

Air District staff recommends supporting this bill because subject to a supporting appropriation, it would expand opportunities for regional air monitoring during emergencies, such as wildfires.

Committee Recommendation: Support

- [SB 1039 \(Grove\)](#) – *Air Resources: Refinery-Related Community Air Monitoring System*

This bill would require air districts with refineries to include a process for a petroleum refinery to provide substantial evidence to the appropriate air district to exclude a pollutant for monitoring in a fence-line monitoring system and would authorize the air district to exclude a pollutant for monitoring at a petroleum refinery fence-line monitoring system if the air district determines that substantial evidence supports certain considerations.

Air District staff recommends opposing this bill because there has been no evidence shown for the need for this bill. Additionally, recent amendments define this exemption as applicable to “petroleum refineries” which creates a purported benefit that is not applicable to refineries using renewable feedstock. This potentially creates uncertainty in existing refinery monitoring rules, and a potential that future changes in air district refinery monitoring rules may additionally require conforming changes in law.

Committee Recommendation: Oppose

- [SB 1075 \(Reyes\)](#) – *Air Resources: Toxic Air Contaminants: Criteria Air Pollutants: Community Emissions Reduction Programs: Local Community Emissions Reduction Plans*

Among other things, this bill would tie requirements to support AB 617 communities to the achievement of Federal Ambient Air Quality Standards. The bill would add one additional member to the governing board of any air district with a selected community or a grant recipient, appointed by CARB in

collaboration with the steering committee of the community. The bill would also restrict land use decisions of cities and counties with AB 617 communities unless the decisions conform with the local Community Emission Reduction Plan (LCERP), and would provide legal recourse to individuals challenging those land decisions.

Air District staff recommends opposing this bill for the above-mentioned reasons, which potentially creates a perpetually unfunded mandate, gives CARB authority to appoint air district board members, and places an undefined role on air districts to be involved in local land use decision-making.

Committee Recommendation: Oppose

Staff Note: This bill was amended after the Committee met on April 15, 2026.

Updated Summary and Staff Recommendation: Among other things, this bill would tie requirements to support AB 617 communities to the achievement of Federal Ambient Air Quality Standards and would prevent Community Emission Reduction Plan (CERP) communities from disbanding except by a 2/3 vote of the Community Steering Committee (CSC). The bill would also require certain land use decisions of cities and counties with AB 617 communities to align with recommendations in the CERP or the original CARB designation findings, require air districts and CARB to enforce recommendations in LCERP communities, and require CARB audits of air district AB 617 programs.

Air District staff originally recommended, supported by the Committee, opposing this bill based on the bill in print at the time of the meeting. The bill was subsequently amended by committee staff for Senate Environmental Quality and Senate Local Government, and amended language was in print on April 23, 2026. Based on the amended language, Air District staff recommends an "Oppose Unless Amended" position, with recommended changes focusing on the items mentioned above.

Staff Recommendation: Oppose Unless Amended

- [SB 1159 \(Cabaldon\)](#) – *Artificial Intelligence: Transparency and Governance*

This bill would specify that, for purposes of the California Public Records Act, the Bagley-Keene Open Meeting Act, the Ralph M. Brown Act, the Political Reform Act of 1974, the Administrative Procedure Act, and CEQA, "person," "interested person," "participant," "member of the public," as applicable, and any other similar terms under each act referring to those who may engage with governmental agencies, do not include artificial intelligence (AI), as defined, systems, autonomous agents, robots, or other nonhuman entities, whether physical or digital. The bill would make findings and declarations related to these provisions.

Air District staff recommends supporting this bill because it would clarify that AI-generated public comments do not need to be considered in Air District decision-making processes.

Committee Recommendation: Support

Additional bill information may be found on the [California Legislative Information](#) website.

BUDGET CONSIDERATION/FINANCIAL IMPACT

None.

Respectfully submitted,

Philip M. Fine  
Executive Officer/APCO

Prepared by: Alan Abbs  
Reviewed by: Viet Tran

ATTACHMENT(S):

1. AB 2057 (DeMaio) - Bill Text - As Amended on March 12, 2026
2. AB 2102 (DeMaio) - Bill Text - As Introduced on February 18, 2026
3. AB 2349 (Solache) - Bill Text - As Introduced on February 19, 2026
4. SB 1039 (Grove) - Bill Text - As Amended on March 19, 2026
5. SB 1075 (Reyes) - Bill Text - As Amended on April 23, 2026
6. SB 1159 (Cabaldon) - Bill Text - As Amended on March 25, 2026

AMENDED IN ASSEMBLY MARCH 12, 2026

CALIFORNIA LEGISLATURE—2025–26 REGULAR SESSION

**ASSEMBLY BILL**

**No. 2057**

---

---

**Introduced by Assembly Member DeMaio**

February 18, 2026

---

---

An act to *add Chapter 15 (commencing with Section 66347) to Division 1 of Title 7 of the Government Code, and to amend Sections 17958.5 and 17958.7 of the Health and Safety Code, relating to ~~building standards: natural gas.~~*

LEGISLATIVE COUNSEL'S DIGEST

AB 2057, as amended, DeMaio. ~~Building standards: natural gas.~~  
*Natural gas: appliances.*

*The Planning and Zoning Law enacts various laws relating to land use, including statewide land use planning, transportation planning, local planning, zoning regulations, and housing development, among other things.*

*This bill would prohibit state agencies and local governments from adopting or enforcing a rule, regulation, resolution, or ordinance that directly or indirectly results in prohibiting the use of gas appliances in residential or nonresidential buildings.*

Existing law, the California Building Standards Law, establishes the California Building Standards Commission (commission) within the Department of General Services. Existing law requires the commission to approve and adopt building standards and to codify those standards in the California Building Standards Code (code). Existing law, the State Housing Law, establishes statewide construction and occupancy standards for buildings used for human habitation.

Existing law requires the building standards adopted and submitted by the department for approval by the commission, as specified, to be adopted by reference, with certain exceptions. Existing law authorizes any city or county to make modifications or changes in those building standards that are published in the code, including to green building standards, upon making an express finding that those modifications or changes are reasonably necessary because of local climatic, geological, or topographical conditions. Existing law requires a copy of those findings, together with the modification or change, to be filed with the commission. Existing law, from June 1, 2025, until June 1, 2031, inclusive, prohibits a city or county from making a modification or change to the building standards described above that are applicable to residential units, unless one of specified conditions are met, and requires the commission to reject a modification or change to any building standard affecting a residential unit and filed by the governing body of a city or county, unless one of those specified conditions are met.

This bill would prohibit a city or county from making a change or modification to the above-described building standards that prohibits the use of natural gas in a residential unit. The bill would also require the commission to reject a modification or change to any building standard affecting a residential unit and filed by the governing body of a city or county that prohibits the use of natural gas in that residential unit.

This bill would include findings that changes proposed by this bill address a matter of statewide concern rather than a municipal affair and, therefore, apply to all cities, including charter cities.

Vote: majority. Appropriation: no. Fiscal committee: yes.  
State-mandated local program: no.

*The people of the State of California do enact as follows:*

1     SECTION 1. Chapter 15 (commencing with Section 66347) is  
2     added to Division 1 of Title 7 of the Government Code, to read:

3

4

*CHAPTER 15. GAS APPLIANCES*

5

6     66347. A state agency or local government, including a charter  
7     city, shall not adopt or enforce a rule, regulation, resolution, or  
8     ordinance, including, but not limited to, an ordinance prohibiting  
9     natural gas hookups for new buildings, that directly or indirectly

1 *results in prohibiting the use of gas appliances in residential or*  
2 *nonresidential buildings.*

3 **SECTION 1.**

4 *SEC. 2.* Section 17958.5 of the Health and Safety Code is  
5 amended to read:

6 17958.5. (a) Except as provided in subdivisions (c) and (d)  
7 and in Section 17922.6, in adopting the ordinances or regulations  
8 pursuant to Section 17958, a city or county may make those  
9 changes or modifications in the requirements contained in the  
10 provisions published in the California Building Standards Code  
11 and the other regulations adopted pursuant to Section 17922,  
12 including, but not limited to, green building standards, as it  
13 determines, pursuant to the provisions of Section 17958.7, are  
14 reasonably necessary because of local climatic, geological, or  
15 topographical conditions.

16 (b) For purposes of this section, a city or county may make  
17 reasonably necessary modifications to the requirements, adopted  
18 pursuant to Section 17922, including, but not limited to, green  
19 building standards, contained in the provisions of the code and  
20 regulations on the basis of local conditions.

21 (c) Commencing October 1, 2025, to June 1, 2031, inclusive, a  
22 city or county shall not make a change or modification as described  
23 in subdivision (a) or (b), including to green building standards,  
24 that is applicable to residential units, unless one of the following  
25 conditions is met:

26 (1) The changes or modifications are substantially equivalent  
27 to changes or modifications that were previously filed by the  
28 governing body of the city or county and were in effect as of  
29 September 30, 2025.

30 (2) The commission deems those changes or modifications  
31 necessary as emergency standards to protect health and safety.

32 (3) The changes or modifications relate to home hardening.

33 (4) The building standards relate to home hardening and are  
34 proposed for adoption by a local fire prevention district pursuant  
35 to Section 13869.7.

36 (5) The changes or modifications are necessary to implement a  
37 local code amendment that is adopted to align with a general plan  
38 approved on or before June 10, 2025, and that permits mixed-fuel  
39 residential construction consistent with federal law while also

1 incentivizing all-electric construction as part of an adopted  
2 greenhouse gas emissions reduction strategy.

3 (6) The changes or modifications are related to administrative  
4 practices, are proposed for adoption during the intervening period  
5 pursuant to Section 18942, and exclusively result in any of the  
6 following:

7 (A) Reductions in time for a local agency to issue a  
8 postentitlement permit.

9 (B) Alterations to a local agency's postentitlement fee schedule.

10 (C) Modernization of, or adoption of, new permitting platforms  
11 and software utilized by the local agency.

12 (D) Reductions in cost of internal operation for a local agency.

13 (E) Establishment, alteration, or removal of local programs  
14 related to enforcement of building code violations or complaints  
15 alleging building code violations.

16 (d) A city or county shall not make a change or modification as  
17 described in subdivision (a) or (b), including to green building  
18 standards, that prohibits the use of natural gas in a residential unit.

19 ~~SEC. 2.~~

20 *SEC. 3.* Section 17958.7 of the Health and Safety Code is  
21 amended to read:

22 17958.7. (a) Except as provided in subdivisions (c) and (e)  
23 and in Section 17922.6, the governing body of a city or county,  
24 before making any modifications or changes pursuant to Section  
25 17958.5, shall make an express finding that such modifications or  
26 changes are reasonably necessary because of local climatic,  
27 geological, or topographical conditions. Such a finding shall be  
28 available as a public record. A copy of those findings, together  
29 with the modification or change expressly marked and identified  
30 to which each finding refers, shall be filed with the California  
31 Building Standards Commission. No modification or change shall  
32 become effective or operative for any purpose until the finding  
33 and the modification or change have been filed with the California  
34 Building Standards Commission.

35 (b) The California Building Standards Commission may reject  
36 a modification or change filed by the governing body of a city or  
37 county if no finding was submitted.

38 (c) Commencing October 1, 2025, to June 1, 2031, inclusive,  
39 the commission shall reject a modification or change to any  
40 building standard affecting a residential unit and filed by the

1 governing body of a city or county, unless one of the following  
2 conditions is met:

3 (1) The changes or modifications are substantially equivalent  
4 to changes or modifications that were previously filed by the  
5 governing body of the city or county and were in effect as of  
6 September 30, 2025.

7 (2) The commission deems those changes or modifications  
8 necessary as emergency standards to protect health and safety.

9 (3) The changes or modifications relate to home hardening.

10 (4) The building standards relate to home hardening and are  
11 proposed for adoption by a local fire prevention district pursuant  
12 to Section 13869.7.

13 (5) The changes or modifications are necessary to implement a  
14 local code amendment that is adopted to align with a general plan  
15 approved on or before June 10, 2025, and that permits mixed-fuel  
16 residential construction consistent with federal law while also  
17 incentivizing all-electric construction as part of an adopted  
18 greenhouse gas emissions reduction strategy.

19 (6) The changes or modifications are related to administrative  
20 practices, are proposed for adoption during the intervening period  
21 pursuant to Section 18942, and exclusively result in any of the  
22 following:

23 (A) Reductions in time for a local agency to issue a  
24 postentitlement permit.

25 (B) Alterations to a local agency's postentitlement fee schedule.

26 (C) Modernization of, or adoption of, new permitting platforms  
27 and software utilized by the local agency.

28 (D) Reductions in cost of internal operation for a local agency.

29 (E) Establishment, alteration, or removal of local programs  
30 related to enforcement of building code violations or complaints  
31 alleging building code violations.

32 (d) (1) The commission, in determining that a modification or  
33 change meets any of the criteria in paragraph (1) to (5), inclusive,  
34 of subdivision (c), may rely on a statement by the local agency to  
35 that effect.

36 (2) The changes or modifications made pursuant to paragraph  
37 (6) of subdivision (c) may be filed with the commission and shall  
38 be reviewed by the commission, in consultation with the  
39 Department of Housing and Community Development, within 60  
40 days of receipt, if requested by the local agency.

1 (e) The commission shall reject a modification or change to any  
 2 building standard affecting a residential unit and filed by the  
 3 governing body of a city or county that prohibits the use of natural  
 4 gas in that residential unit.

5 ~~SEC. 3.~~

6 *SEC. 4.* The Legislature finds and declares that Sections 1 ~~and~~  
 7 *2 to 3, inclusive,* of this act *adding Chapter 15 (commencing with*  
 8 *Section 66347) to Division 1 of Title 7 of the Government Code*  
 9 *and amending Sections 17958.5 and 17958.7 of the ~~Government~~*  
 10 *Health and Safety Code* address a matter of statewide concern  
 11 rather than a municipal affair as that term is used in Section 5 of  
 12 Article XI of the California Constitution. Therefore, Sections ~~1~~  
 13 ~~and 2~~ *1 to 3, inclusive,* of this act apply to all cities, including  
 14 charter cities.

O

**ASSEMBLY BILL**

**No. 2102**

---

---

**Introduced by Assembly Member DeMaio**

February 18, 2026

---

---

An act to add Section 21080.36 to, to add Article 3.5 (commencing with Section 4138) to Chapter 1 of Part 2 of Division 4 of, and to add Part 5 (commencing with Section 4970) to Division 4 of, the Public Resources Code, relating to wildfire.

LEGISLATIVE COUNSEL'S DIGEST

AB 2102, as introduced, DeMaio. Wildfire: vegetation management: fuel reduction activities.

(1) Existing law establishes in the Natural Resources Agency the Department of Forestry and Fire Protection, and requires the department to be responsible for, among other things, fire protection and prevention, as provided. Existing law describes state responsibility areas as areas of the state in which the financial responsibility of preventing and suppressing fires has been determined by the State Board of Forestry and Fire Protection to be primarily the responsibility of the state. Existing law requires the State Fire Marshal to classify lands within state responsibility areas into fire hazard severity zones and, by regulation, designate fire hazard severity zones and assign to each zone a rating reflecting the degree of severity of fire hazard that is expected to prevail in the zone, as provided. Existing law also requires the State Fire Marshal to identify areas of the state as moderate, high, and very high fire hazard severity zones based on specified criteria. Existing law requires, within 120 days of receiving a recommendation from the State Fire Marshal that identifies fire hazard severity zones, described above,

a local agency to designate, by ordinance, fire hazard severity zones in its jurisdiction, as provided.

This bill would, on or before January 1, 2028, and every 2 years thereafter, require the department or a local entity to conduct an assessment, as provided, of all undeveloped public lands for which it is primarily responsible for preventing and suppressing fires to ensure that the public land is not a severe fire hazard. The bill would require this assessment to be posted on the department's and local entity's internet website and would require a local entity conducting the assessment to submit its assessment to the department. The bill would require all public lands, on or before January 1, 2028, to have 200-foot firebreaks on all borders with private property.

This bill would, when the department or local entity acquires private undeveloped land, require the department or a local entity that is primarily responsible for preventing and suppressing fires on that land to create a plan on how the land will be managed with regard to fire prevention, and to report the cost of keeping the land managed. The bill would require the department and the local entity to post this information on its respective internet website and would require a local entity preparing this information to submit it to the department.

To the extent that this bill would impose new duties on local government agencies, the bill would create a state-mandated local program.

(2) The California Environmental Quality Act (CEQA) requires a lead agency, as defined, to prepare, or cause to be prepared, and certify the completion of an environmental impact report on a project that it proposes to carry out or approve that may have a significant effect on the environment or to adopt a negative declaration if the lead agency finds that the project will not have that effect. CEQA also requires a lead agency to prepare a mitigated negative declaration for a project that may have a significant effect on the environment if revisions in the project would avoid or mitigate that effect and there is no substantial evidence that the project, as revised, would have a significant effect on the environment.

This bill would authorize property owners to conduct wildfire fuel reduction activities, as described, on their own private property if the activities comply with specified guidelines. The bill would require fire chiefs of a county with jurisdiction over that private property in which the activities are conducted to establish these guidelines, as provided. The bill would exempt from CEQA these activities regardless of the

acreage involved, if the activity is conducted solely for wildfire fuel reduction and not for development purposes. The bill would prohibit state agencies from imposing additional requirements on these activities, as provided.

By imposing new duties on county fire chiefs, and because a lead agency would be required to determine whether a project qualifies for this exemption, the bill would create a state-mandated local program.

(3) The California Constitution requires the state to reimburse local agencies and school districts for certain costs mandated by the state. Statutory provisions establish procedures for making that reimbursement.

This bill would provide that with regard to certain mandates no reimbursement is required by this act for a specified reason.

With regard to any other mandates, this bill would provide that, if the Commission on State Mandates determines that the bill contains costs so mandated by the state, reimbursement for those costs shall be made pursuant to the statutory provisions noted above.

Vote: majority. Appropriation: no. Fiscal committee: yes.

State-mandated local program: yes.

*The people of the State of California do enact as follows:*

1 SECTION 1. Article 3.5 (commencing with Section 4138) is  
2 added to Chapter 1 of Part 2 of Division 4 of the Public Resources  
3 Code, to read:

4  
5 Article 3.5. Force State and Local Government to Be Firewise  
6 Neighbors Act  
7

8 4138. This article shall be known, and may be cited, as the  
9 Force State and Local Government to Be Firewise Neighbors Act.

10 4138.5. For purposes of this article, the following terms shall  
11 apply:

12 (a) "Fire break" means a gap in vegetation or other combustible  
13 material that acts as a barrier to slow or stop brush fire or wildfire.

14 (b) "Local entity" means a city, county, city or county, or other  
15 local jurisdiction with fire prevention and suppression authority.

16 (c) "Public land" means undeveloped land under the control of  
17 the department or a local entity.

18 (d) "Severe fire hazard" means land designated as a moderate,  
19 high, or very high fire hazard severity zone as identified by the

1 State Fire Marshal pursuant to Section 4202 of this code and  
2 Section 51178 of the Government Code or as identified by a local  
3 agency pursuant to Section 51179 of the Government Code.

4 4139. (a) (1) On or before January 1, 2028, and every two  
5 years thereafter, the department or a local entity shall conduct an  
6 assessment on all public lands for which it is primarily responsible  
7 for preventing and suppressing fires pursuant Sections 4102 and  
8 4125 to ensure that the public land is not a severe fire hazard.

9 (2) The assessment shall include all of the following:

10 (A) Information on the vegetation management plan, including,  
11 but not limited to, what and how often vegetation management is  
12 currently being done.

13 (B) Information on the cost of vegetation management described  
14 in subparagraph (A).

15 (b) The department and the local entity shall post the assessment  
16 pursuant to paragraph (1) of subdivision (a) on its respective  
17 internet website. If a local entity prepares the assessment, the local  
18 entity shall also submit its assessment to the department.

19 4139.5. (a) When the department or a local entity acquires  
20 private undeveloped land, the department or a local entity that is  
21 primarily responsible for preventing and suppressing fires pursuant  
22 to Section 4125 shall, within one year of acquisition, do both of  
23 the following:

24 (1) Create a plan on how the land will be managed with regard  
25 to fire prevention.

26 (2) Report the cost of keeping the land managed.

27 (b) The department or the local entity shall post the information  
28 pursuant to subdivision (a) on its respective internet website. If a  
29 local entity prepares the information, the local entity shall also  
30 submit this information to the department.

31 4140. On or before January 1, 2028, all public lands shall have  
32 a 200 foot fire break on all borders with privately owned land.

33 SEC. 2. Part 5 (commencing with Section 4970) is added to  
34 Division 4 of the Public Resources Code, to read:

35

36 PART 5. WILDFIRE FUEL REDUCTION

37

38 4970. (a) Notwithstanding any other law, a property owner  
39 may, by right, conduct wildfire fuel reduction activities on their

1 private property if those activities comply with the guidelines  
2 established pursuant to Section 4971.

3 (b) For purposes of this section, “wildfire fuel reduction  
4 activities” include, but are not limited to, any of the following:

- 5 (1) Removal of dead, dying, diseased, or hazardous trees.
- 6 (2) Removal or thinning of brush, chaparral, shrubs, and grasses.
- 7 (3) Thinning of trees to reduce ladder fuels and canopy density.
- 8 (4) Creation and maintenance of defensible space and fuel  
9 breaks.

10 (5) Removal of invasive plant species that increase fire risk.

11 (6) Maintenance of emergency access routes and firebreaks.

12 (c) Wildfire fuel reduction activities pursuant to this section  
13 shall be exempt from the California Environmental Quality Act  
14 (Division 13 (commencing with Section 21000)) pursuant to  
15 Section 21080.36.

16 (d) Notwithstanding any other law, a state agency, including,  
17 but not limited to, the State Air Resources Board or its successor  
18 entity, shall not impose additional permitting, emissions limitation,  
19 or regulatory requirements on activities conducted pursuant to this  
20 section.

21 4971. (a) Guidelines governing wildfire fuel reduction  
22 activities pursuant to Section 4970, shall be established by the fire  
23 chief of a county with jurisdiction over the property or the fire  
24 chief’s designee, as provided in subdivisions (b) and (c).

25 (b) The guidelines may include objective standards relating to,  
26 but not limited to, all of the following:

- 27 (1) Maximum slope disturbance.
- 28 (2) Erosion and sediment control measures.
- 29 (3) Seasonal timing restrictions for fire safety.
- 30 (4) Disposal or treatment of removed vegetation.
- 31 (5) Protection of critical infrastructure and evacuation routes.

32 (c) The guidelines shall be all of the following:

- 33 (1) Objective and uniformly applicable within the jurisdiction.
- 34 (2) Published and publicly accessible.
- 35 (3) Limited to matters directly related to wildfire risk and fire  
36 suppression effectiveness.

37 4972. (a) This part shall preempt any local ordinance,  
38 regulation, or policy that prohibits or materially restricts wildfire  
39 fuel reduction activities conducted in compliance with this part.

1 (b) Notwithstanding any other law, a city, county, or special  
2 district shall not impose discretionary review, conditional use  
3 permits, or additional environmental review requirements for  
4 activities authorized by this part.

5 SEC. 3. Section 21080.36 is added to the Public Resources  
6 Code, to read:

7 21080.36. This division shall not apply to wildfire fuel  
8 reduction activities pursuant to Section 4970 regardless of the  
9 acreage involved, if the activity is conducted solely for wildfire  
10 fuel reduction and not for development purposes.

11 SEC. 4. No reimbursement is required by this act pursuant to  
12 Section 6 of Article XIII B of the California Constitution because  
13 a local agency or school district has the authority to levy service  
14 charges, fees, or assessments sufficient to pay for the program or  
15 level of service mandated by this act, within the meaning of Section  
16 17556 of the Government Code.

17 However, if the Commission on State Mandates determines that  
18 this act contains other costs mandated by the state, reimbursement  
19 to local agencies and school districts for those costs shall be made  
20 pursuant to Part 7 (commencing with Section 17500) of Division  
21 4 of Title 2 of the Government Code.

O

**ASSEMBLY BILL**

**No. 2349**

---

---

**Introduced by Assembly Member Solache**

February 19, 2026

---

---

An act to add Chapter 9 (commencing with Section 39950) to Part 2 of Division 26 of the Health and Safety Code, relating to air pollution.

LEGISLATIVE COUNSEL'S DIGEST

AB 2349, as introduced, Solache. State Air Resources Board: regional air quality incident response program.

Existing law generally designates the State Air Resources Board as the state agency with the primary responsibility for the control of vehicular air pollution, and air pollution control districts and air quality management districts with the primary responsibility for the control of air pollution from all sources other than vehicular sources. Existing law requires the state board to inventory sources of air pollution within the air basins of the state, determine the kinds and quantity of air pollutants, and monitor air pollutants in cooperation with districts and other agencies.

This bill would require the state board to expand its incident air monitoring program, subject to an appropriation by the Legislature for those purposes, to provide support for a regional network of air quality incident response centers, including at least one air quality incident response and evaluation center located at the South Coast Air Quality Management District, in order to facilitate emergency air monitoring response at the local and regional level. The bill would require each air quality incident response center to be operated by the state board or an air district and would require the state board and each district that operates an air quality incident response center to coordinate to provide

emergency air monitoring response for disasters or other crises impacting air quality and public health in the state. The bill would provide that funding made available by the Legislature for purposes of these provisions may be used for various purposes, including program funding to plan, create, equip, and maintain air quality incident response centers.

To the extent that the bill would expand the duties of an air district, the bill would impose a state-mandated local program.

The California Constitution requires the state to reimburse local agencies and school districts for certain costs mandated by the state. Statutory provisions establish procedures for making that reimbursement.

This bill would provide that, if the Commission on State Mandates determines that the bill contains costs mandated by the state, reimbursement for those costs shall be made pursuant to the statutory provisions noted above.

Vote: majority. Appropriation: no. Fiscal committee: yes. State-mandated local program: yes.

*The people of the State of California do enact as follows:*

1 SECTION 1. Chapter 9 (commencing with Section 39950) is  
2 added to Part 2 of Division 26 of the Health and Safety Code, to  
3 read:

4  
5 CHAPTER 9. REGIONAL AIR QUALITY INCIDENT RESPONSE  
6 PROGRAM  
7

8 39950. For purposes of this chapter, the following definitions  
9 apply:

10 (a) "Air contaminant" includes any toxic air contaminant  
11 designated or identified pursuant to Chapter 3.5 (commencing with  
12 Section 39650), and as defined in Section 39013, and any substance  
13 as listed in the Table of Standards pursuant to Section 70200 of  
14 Title 17 of the California Code of Regulations.

15 (b) "Air quality incident response center" means an air quality  
16 incident response center established pursuant to this chapter to  
17 facilitate emergency air monitoring.

18 39951. Subject to an appropriation by the Legislature for  
19 purposes of this chapter, the state board shall expand its incident  
20 air monitoring program to provide support in accordance with this

1 chapter for a regional network of air quality incident response  
2 centers in order to facilitate emergency air monitoring response at  
3 the local and regional level.

4 39952. (a) (1) The state board and the districts shall jointly  
5 select each location throughout the state where an air quality  
6 incident response center will be established by the state board or  
7 a district for purposes of this chapter, including at least one air  
8 quality incident response and evaluation center located at the south  
9 coast district.

10 (2) Before establishing an air quality incident response center  
11 within its jurisdiction, a district shall coordinate with the state  
12 board and any other relevant district to develop operational plans  
13 for the air quality incident response center.

14 (3) Each entity shall be responsible for operating the air quality  
15 incident response center that it establishes pursuant to paragraph  
16 (1).

17 (b) The state board and each district that operates an air quality  
18 incident response center shall coordinate to provide emergency  
19 air monitoring response for disasters or other crises impacting air  
20 quality and public health in the state, as determined by the state  
21 board and those districts.

22 (c) The state board and each district that operates an air quality  
23 incident response center shall only be responsible for performing  
24 the duties set forth in this chapter to the extent that funding is  
25 provided by the Legislature for those purposes.

26 39953. Funding made available by the Legislature for purposes  
27 of this chapter may be used, but is not limited to being used, for  
28 any of the following purposes:

29 (a) Program funding to plan, create, equip, and maintain air  
30 quality incident response centers, including for the acquisition of  
31 monitoring equipment and systems, vehicles, and other necessary  
32 equipment, and facilities, needed to support air quality incident  
33 response centers, and to plan, develop, conduct training on, and  
34 implement incident response protocols.

35 (b) Air quality data collection, maintenance, analysis,  
36 presentation, dissemination, modeling, and publishing, and the  
37 integration of that data into a unified command or joint information  
38 center, and other related activities.

39 (c) The funding of staffing resources, including regional  
40 emergency response coordinators and technical staff at districts

1 that operate air quality incident response centers, develop plans,  
2 prepare for, and respond during, incidents and as needed for  
3 investigation and recovery efforts.

4 (d) Training and preparedness exercises for state board staff  
5 and the staff of districts that operate air quality incident response  
6 centers to facilitate expeditious, efficient, and effective emergency  
7 air monitoring responses to provide air quality information to the  
8 public and protect public health.

9 (e) Providing expertise to translate air monitoring data  
10 collection, analyses, and modeling results in terms of impacts on  
11 public health.

12 (f) Coordinating with relevant state and local agencies, local  
13 governments, and public health departments, including districts,  
14 to provide unified command and joint information centers, and  
15 other organizations with air quality data and analysis to inform the  
16 public and local response and recovery efforts.

17 39954. As part of the operation of an air quality incident  
18 response center, air quality monitoring may be conducted for  
19 targeted air contaminants of concern, as identified by the state  
20 board or the district operating that air quality incident response  
21 center, during disaster or emergency situations and during the  
22 recovery period from a disaster or emergency to aid impacted  
23 communities, and may be conducted, as needed, in coordination  
24 with unified command centers, joint information centers, other  
25 state agencies, local public health agencies, and other entities, as  
26 appropriate.

27 SEC. 2. If the Commission on State Mandates determines that  
28 this act contains costs mandated by the state, reimbursement to  
29 local agencies and school districts for those costs shall be made  
30 pursuant to Part 7 (commencing with Section 17500) of Division  
31 4 of Title 2 of the Government Code.

O

AMENDED IN SENATE MARCH 19, 2026

**SENATE BILL**

**No. 1039**

---

---

**Introduced by Senator Grove**

February 11, 2026

---

---

An act to amend Section 42705.6 of the Health and Safety Code, relating to air resources.

LEGISLATIVE COUNSEL'S DIGEST

SB 1039, as amended, Grove. Air resources: refinery-related community air monitoring system.

Existing law requires a refinery-related community air monitoring system to be installed near each refinery, as provided, and requires the monitoring system to include equipment capable of measuring compounds emitted to the atmosphere from refinery processes. Existing law requires owners or operators of petroleum refineries to develop, install, operate, and maintain a fence-line monitoring system in accordance with guidance developed by the appropriate regional air pollution control district or regional air quality management district.

This bill would ~~prohibit~~ *require* guidance adopted to implement the fence-line monitoring system ~~from requiring the system to monitor emissions of substances that cannot be generated by the facility that is being monitored.~~ *to include a process for a petroleum refinery to provide substantial evidence to the appropriate air district to exclude a pollutant for monitoring in a fence-line monitoring system and would authorize the air district to exclude a pollutant for monitoring at a petroleum refinery fence-line monitoring system if the air district determines that substantial evidence supports certain considerations.* Because the bill would require air districts to revise their guidance related to the

fence-line monitoring system, this bill would impose a state-mandated local program.

The California Constitution requires the state to reimburse local agencies and school districts for certain costs mandated by the state. Statutory provisions establish procedures for making that reimbursement.

This bill would provide that no reimbursement is required by this act for a specified reason.

Vote: majority. Appropriation: no. Fiscal committee: yes.  
 State-mandated local program: yes.

*The people of the State of California do enact as follows:*

1 SECTION 1. Section 42705.6 of the Health and Safety Code  
 2 is amended to read:

3 42705.6. (a) For purposes of this section, the following  
 4 definitions apply:

5 (1) “Refinery-related community air monitoring system” means  
 6 equipment that measures and records air pollutant concentrations  
 7 in the ambient air at or near sensitive receptor locations near a  
 8 petroleum refinery and that may be useful for estimating associated  
 9 pollutant exposures and health risks and in determining trends in  
 10 air pollutant levels over time.

11 (2) “Fence-line monitoring system” means equipment that  
 12 measures and records air pollutant concentrations at or adjacent  
 13 to a petroleum refinery and that may be useful for detecting or  
 14 estimating the quantity of fugitive emissions, gas leaks, and other  
 15 air emissions from the refinery.

16 (b) Notwithstanding Section 42708, and on or before January  
 17 1, 2020, a refinery-related community air monitoring system shall  
 18 be installed near each refinery that is consistent with the  
 19 requirements and guidance applicable to the siting of air quality  
 20 monitors as established by the federal Environmental Protection  
 21 Agency and that meets all of the following requirements:

22 (1) A district shall design, develop, install, operate, and maintain  
 23 the refinery-related community air monitoring system, which shall  
 24 be operated and maintained in accordance with guidance from the  
 25 appropriate district. A district may contract with a third party to  
 26 implement this paragraph.

27 (2) The refinery-related community air monitoring system shall  
 28 include equipment capable of measuring compounds emitted to

1 the atmosphere from refinery processes, as determined by the  
2 appropriate district.

3 (c) (1) On or before January 1, 2020, the owner or operator of  
4 a petroleum refinery shall develop, install, operate, and maintain  
5 a fence-line monitoring system in accordance with guidance  
6 developed by the appropriate district.

7 (2) Guidance adopted pursuant to this section shall ~~not require~~  
8 ~~a fence-line monitoring system to monitor emissions of substances~~  
9 ~~that cannot be generated by the facility that is being monitored.~~  
10 *include a process for a petroleum refinery to provide substantial*  
11 *evidence to the appropriate district to exclude a pollutant for*  
12 *monitoring in a fence-line monitoring system.*

13 (3) *Recognizing that emissions vary among refineries, a district*  
14 *may exclude a pollutant for monitoring at a petroleum refinery*  
15 *fence-line monitoring system if the district determines that*  
16 *substantial evidence supports any of the following:*

17 (A) *The pollutant would not be released through routine and*  
18 *nonroutine operations, activities, and processes of the petroleum*  
19 *refinery.*

20 (B) *Realtime monitoring of the pollutant is technologically*  
21 *infeasible.*

22 (C) *Technical justifications deemed appropriate by the district.*

23 (d) The district and the owner or operator of a petroleum refinery  
24 shall collect real-time data from the refinery-related community  
25 air monitoring system and the fence-line monitoring system and  
26 shall maintain records of that data. To the extent feasible, the data  
27 generated by these systems shall be provided to the public as  
28 quickly as possible in a publicly accessible format.

29 (e) Guidance developed by a district pursuant to this section  
30 shall take into account technological capabilities and incorporate  
31 input from affected parties and, to the extent feasible, shall be  
32 informed by refinery-related guidance in the monitoring plan  
33 prepared pursuant to subdivision (b) of Section 42705.5.

34 (f) (1) Except as provided in paragraph (2), the owner or  
35 operator of a petroleum refinery shall be responsible for the costs  
36 associated with implementing this section.

37 (2) To the extent a refinery-related community air monitoring  
38 system is intentionally used by a district to monitor emissions from  
39 sources under its jurisdiction other than a petroleum refinery, the

1 district shall ensure the costs of the system are shared in a  
2 reasonably equitable manner.

3 SEC. 2. No reimbursement is required by this act pursuant to  
4 Section 6 of Article XIII B of the California Constitution because  
5 a local agency or school district has the authority to levy service  
6 charges, fees, or assessments sufficient to pay for the program or  
7 level of service mandated by this act, within the meaning of Section  
8 17556 of the Government Code.

O

AMENDED IN SENATE APRIL 23, 2026

AMENDED IN SENATE MARCH 25, 2026

**SENATE BILL**

**No. 1075**

---

---

**Introduced by Senator Reyes**

February 13, 2026

---

---

An act to amend Section 44391.2 of, and to add Sections 44391.6, 44391.7, 44391.8, and 44391.9 to, the Health and Safety Code, relating to air resources.

LEGISLATIVE COUNSEL'S DIGEST

SB 1075, as amended, Reyes. Air resources: toxic air contaminants: criteria air pollutants: community emissions reduction programs: local community emissions reduction plans.

Existing law requires the State Air Resources Board to prepare a statewide strategy to reduce emissions of toxic air contaminants and criteria air pollutants in communities affected by a high cumulative exposure burden that includes an assessment and identification of those communities. Existing law requires the statewide strategy to be updated at least once every 5 years. Existing law requires the state board, based on the assessment and identification, to select locations around the state for preparation of community emissions reduction programs. Existing law requires the assessment and identification to prioritize disadvantaged communities, as defined. Existing law requires the regional air quality management district or the regional air pollution control district encompassing the location selected by the state board, within one year of selection, to adopt a community emissions reduction program to achieve emissions reductions for the location selected using cost-effective measures, as provided. Existing law requires the state board to provide grants to community-based organizations for technical

assistance and to support community participation in the implementation of the statewide strategy. Under this existing regulatory authority, the state board provides grants to development and implement local community emissions reduction plans.

This bill would revise the definition of “disadvantaged community” to include a disadvantaged unincorporated community. ~~The bill would require the statewide strategy to be updated on or before July 1, 2027, and every 3 years thereafter. By expanding the definition of “disadvantaged community,” this bill would expand the duties of districts in the preparation of community emissions reduction programs.~~ The bill would require the local community emissions reduction plans be submitted to the state board for review and approval and would authorize the state board or the relevant air district to enforce those plans. The bill would specify that a steering committee formed by an air district to assist it in the development and implementation of a community emissions reduction program remains active until the emissions objectives identified in the program are ~~achieved~~ *achieved or more than 5 years have passed since the adoption of the community emissions reduction program and  $\frac{2}{3}$  of the members of the committee vote to disband the committee.* The bill would require members of the steering committee to meet certain requirements. The bill would specify eligible uses for the grants provided and would authorize the state board to audit and to take corrective action if those resources are improperly used.

~~This bill would require a local government with land use planning authority to align its local land use decisions, as specified, to support the goals of an approved community emissions reduction program, approved local community emissions reduction plan, or both program and plan, and the environmental justice element of the general plan of the local government and to prevent new, substantial modification or substantial expanded uses that contribute to poor air quality, as provided. The bill would authorize a local land use agency, as provided, to make a land use decision that does not align with the community emissions reduction program or local community emissions reduction plan if the decision serves an essential environmental, health, or safety need of the applicable community and there is no reasonable alternative. The bill would authorize a person living in a community with a community emissions reduction program or a local community emissions reduction plan to seek a de novo review of a land use decision that does not align with the program or plan. The bill would authorize the Attorney General~~

~~to require the local land use agency to take certain actions if it finds that the challenged land use decision did not comply with those requirements. Because the bill would impose additional duties on local land use agencies, this bill would impose a state-mandated local program.~~

*This bill would require a city, including a charter city, or a county for which an approved community emissions reduction program or local community emissions reduction plan has been prepared, before approving a commercial or industrial development located on a site of 5 acres or more, to consider the community emissions reduction program or local community emissions reduction plan, or both program and plan. The bill would define “consider” to mean analyze the potential air quality impact of local land use approval of the industrial or commercial development by identifying whether the approval would further contribute to the poor air quality indicators, as specified, and consider adopting applicable mitigation measures contained in the community emissions reduction program or local community emissions reduction plan to mitigate or avoid further contribution to those poor air quality indicators. The bill would require the city or county, upon completion of the analysis and before the approval, to present its findings and analyses in support of its conclusions at a duly noticed meeting of its governing body of planning commission. To the extent the bill would impose additional duties on a city or county in its approval of commercial and industrial development, this bill would impose a state-mandated local program.*

~~This bill would add one additional member of the governing board of an air district with a community that is in a location that has been selected for the preparation of a community emissions reduction program who is a member of a bona fide environmental justice organization or is a member of a steering committee of the air district and who is appointed by the state board, in collaboration with the steering committee. By expanding the membership of the governing board of air districts, this bill would impose a state-mandated local program. The bill would require the state board, on or before June 30, 2027, and annually thereafter, to report to the appropriate subcommittees of the budget committee of the Legislature about the progress the state board has made to implement the statewide strategy and the community emissions reduction programs. The bill would require the Secretary for Environmental Protection to periodically convene representatives of agencies and departments with the California Environmental Protection~~

Agency to ensure coordination among agencies and departments with jurisdiction over pollution sources included in a community emissions reduction program to address concerns raised about those sources.

The California Constitution requires the state to reimburse local agencies and school districts for certain costs mandated by the state. Statutory provisions establish procedures for making that reimbursement.

This bill would provide that with regard to certain mandates no reimbursement is required by this act for a specified reason.

With regard to any other mandates, this bill would provide that, if the Commission on State Mandates determines that the bill contains costs so mandated by the state, reimbursement for those costs shall be made pursuant to the statutory provisions noted above.

Vote: majority. Appropriation: no. Fiscal committee: yes.  
State-mandated local program: yes.

*The people of the State of California do enact as follows:*

1 SECTION 1. Section 44391.2 of the Health and Safety Code  
2 is amended to read:  
3 44391.2. (a) For purposes of this section, the following  
4 definitions apply:  
5 (1) “Disadvantaged community” means a community identified  
6 as disadvantaged pursuant to Section 39711 or a disadvantaged  
7 unincorporated community as defined in Section 65302.10 of the  
8 Government Code.  
9 (2) “Sensitive receptors” includes the same locations as specified  
10 in paragraph (5) of subdivision (a) of Section 42705.5.  
11 (b) (1) On or before October 1, 2018, the state board shall  
12 prepare, in consultation with the Scientific Review Panel on Toxic  
13 Air Contaminants, the districts, the Office of Environmental Health  
14 Hazard Assessment, environmental justice organizations, affected  
15 industry, and other interested stakeholders, a statewide strategy to  
16 reduce emissions of toxic air contaminants and criteria air  
17 pollutants in communities affected by a high cumulative exposure  
18 burden. ~~The board shall update the statewide strategy at least~~  
19 *once every five years.*  
20 (2) *In preparing the statewide strategy, the state board shall*  
21 *conduct at least one public workshop in each of the northern,*  
22 *central, and southern parts of the state. The statewide strategy shall*  
23 *include criteria for the development of community emissions*

1 reduction programs. The criteria presented in the statewide strategy  
2 shall include, but are not limited to, all of the following:

3 (A) An assessment and identification of communities with high  
4 cumulative exposure burdens for toxic air contaminants and criteria  
5 air pollutants. The assessment shall prioritize disadvantaged  
6 communities and sensitive receptor locations based on one or more  
7 of the following:

8 (i) Best available modeling information.

9 (ii) Existing air quality monitoring information.

10 (iii) Existing public health data based on consultation with the  
11 Office of Environmental Health Hazard Assessment.

12 (iv) The monitoring results obtained pursuant to Section  
13 42705.5.

14 (B) A methodology for assessing and identifying the contributing  
15 sources or categories of sources, including, but not limited to,  
16 stationary and mobile sources, and an estimate of their relative  
17 contribution to elevated exposure to air pollution in impacted  
18 communities identified pursuant to subparagraph (A).

19 (C) An assessment of whether a district should update and  
20 implement the risk reduction audit and emissions reduction plan  
21 developed pursuant to Section 44391 for a facility to achieve  
22 emissions reductions commensurate with its relative contribution,  
23 if the facility's emissions either cause or significantly contribute  
24 to a material impact on a sensitive receptor location or  
25 disadvantaged community, based on data available for assessment  
26 pursuant to subparagraph (A) or other relevant data.

27 (D) An assessment of the existing and available measures for  
28 reducing emissions from the contributing sources or categories of  
29 sources identified pursuant to subparagraph (B), including, but not  
30 limited to, best available control technology, as defined in Section  
31 40405, best available retrofit control technology, as defined in  
32 Section 40406, and best available control technology for toxic air  
33 contaminants, as defined in Section 39666.

34 ~~(2) On or before July 1, 2027, and every three years thereafter,~~  
35 ~~the state board shall update the statewide strategy prepared pursuant~~  
36 ~~to paragraph (1).~~

37 (c) (1) Based on the assessment and identification pursuant to  
38 subparagraph (A) of paragraph (1) of subdivision (b) and updates  
39 to the assessment and identification, the state board shall select,  
40 concurrent with the statewide strategy, locations around the state

1 for preparation of community emissions reduction programs. The  
2 state board shall select additional locations annually thereafter, as  
3 appropriate.

4 (2) (A) Within two years of the state board's selection, the  
5 district encompassing a location selected pursuant to this  
6 subdivision shall adopt, in consultation with the state board,  
7 individuals, community-based organizations, affected sources, and  
8 local governmental bodies in the affected community, a community  
9 emissions reduction program to achieve emissions reductions for  
10 the location selected using cost-effective measures identified  
11 pursuant to subparagraph (D) of paragraph (1) of subdivision (b).

12 (B) A district, with the agreement of the state board and a  
13 majority of the persons who are designated by the district to  
14 participate in the development and adoption of the community  
15 emissions reduction program, may take up to one additional year  
16 to adopt a community emissions reduction program pursuant to  
17 subparagraph (A).

18 (3) The community emissions reduction programs shall be  
19 consistent with the statewide strategy and include emissions  
20 reduction targets, specific reduction measures, a schedule for the  
21 implementation of measures, and an enforcement plan.

22 (4) Local community emissions reduction plans developed in  
23 accordance with the statewide strategy prepared pursuant to  
24 subdivision (b), also known as the "Community Air Protection  
25 Blueprint" or "Blueprint" pursuant to Section 44391.5, shall be  
26 consistent with the statewide strategy.

27 (5) The community emissions reduction programs and local  
28 community emissions reduction plans shall be submitted to the  
29 state board for review and approval within 60 days of the receipt  
30 of the program. Programs that are rejected shall be resubmitted  
31 within 30 days. To the extent that a program, in whole or in part,  
32 is not approvable, the state board shall initiate a public process to  
33 discuss options for achieving an approvable program. Concurrent  
34 with the public process to achieve an approvable program, the state  
35 board shall develop and implement the applicable mobile source  
36 elements in the draft program to commence achievement of  
37 emissions reductions.

38 (6) The community emissions reduction programs or local  
39 community emissions reduction plans shall result in emissions  
40 reductions in the community, based on monitoring or other data.

1 (7) In implementing a community emissions reduction program,  
2 the district and the state board shall be responsible for measures  
3 consistent with their respective authorities.

4 (8) A district encompassing a location selected pursuant to this  
5 subdivision shall prepare an annual report summarizing the results  
6 and actions taken to further reduce emissions pursuant to the  
7 community emissions reduction program.

8 (9) Compliance with a community emissions reduction program  
9 prepared pursuant to this section or a local community emissions  
10 reduction plan developed pursuant to a grant provided under  
11 subdivision (d), including its implementation, shall be enforceable  
12 by the district and state board, as applicable.

13 (10) (A) A steering committee formed by a district for a location  
14 selected for preparation of a community emissions reduction  
15 program pursuant to this subdivision or a location for which a local  
16 community emissions reduction plan is developed in accordance  
17 with the statewide strategy prepared pursuant to subdivision (b),  
18 also known as the “Community Air Protection Blueprint” or  
19 “Blueprint” pursuant to Section 44391.5, shall remain active until  
20 ~~the~~ *either of the following occurs:*

21 (i) *The emissions objectives identified in the program are*  
22 *achieved.*

23 (ii) *More than five years have passed since the adoption of the*  
24 *community emissions reduction program and two-thirds of the*  
25 *members of the steering committee vote to disband the committee.*

26 (B) The steering committee shall meet both of the following:

27 (i) All members of the steering committee live, work, or own  
28 businesses within the community reduction program area or local  
29 community emissions reduction plan area and a majority of the  
30 members are residents. For purposes of this clause, employment  
31 by a nonprofit organization that is engaged in the support of  
32 community members in a program area or employment by a  
33 for-profit company or organization that has workers or managers  
34 working at a facility located in a program area constitute working  
35 within the program area.

36 (ii) The steering committee uses an open and transparent  
37 nomination process to select members and the membership of the  
38 committee reflects the diverse makeup of the community in the  
39 program area.

1 (d) The state board shall provide grants to community-based  
 2 organizations for technical assistance and to support community  
 3 participation in the implementation of this section and Section  
 4 42705.5 to support the implementation of strategies that directly  
 5 reduce emissions or exposure to air pollution in disadvantaged  
 6 communities.

7 (e) The requirements of this section shall apply to all community  
 8 ~~emission~~ *emissions* reduction programs or local community  
 9 emissions reduction plans developed pursuant to a grant provided  
 10 under subdivision (d), until attainment with the federal Clean Air  
 11 Act (42 U.S.C. Sec. 7401 et seq.) is achieved.

12 (f) The state board may audit and take corrective action if a  
 13 ~~district or other stakeholder~~ is found to improperly use the  
 14 resources allocated according to this section. Eligible uses of grant  
 15 funding provided pursuant to this section shall include, but not be  
 16 limited to, any of the following:

17 (1) Community-led deployment of technologies, practices, or  
 18 projects that result in measurable or meaningful reductions in  
 19 emissions or exposure to air pollution.

20 (2) Local mitigation strategies that address emission sources  
 21 identified in community emissions reduction programs or local  
 22 community emissions reduction plans.

23 (3) Projects that improve air quality outcomes through  
 24 neighborhood- or household-level interventions, as identified in  
 25 collaboration with community residents and stakeholders.

26 (4) Other initiatives that align with the goals of this section and  
 27 support the implementation of community emissions reduction  
 28 programs and local community emissions reduction plans  
 29 developed pursuant to this chapter.

30 (5) *Community monitoring efforts.*

31 ~~SEC. 2. Section 44391.6 is added to the Health and Safety~~  
 32 ~~Code, to read:~~

33 ~~44391.6. (a) (1) A local government with land use planning~~  
 34 ~~authority that includes a location selected for the preparation of a~~  
 35 ~~community emissions reduction program or a location for which~~  
 36 ~~a local community emissions reduction plan will be or has been~~  
 37 ~~prepared pursuant to the statewide strategy shall comply with the~~  
 38 ~~community emissions reduction program or local community~~  
 39 ~~emissions reduction plan or both program and plan that are~~  
 40 ~~approved by the state board and with the environmental justice~~

1 element, as described in subdivision (h) of Section 65302 of the  
2 Government Code, in the general plan of the local government. If  
3 any inconsistency exist among the program, plan, or element, the  
4 most health protective standard shall apply.

5 (2) For purposes of paragraph (1), “compliance” means aligning  
6 local land use decisions, including, but not limited to, long-term  
7 land use planning through general plans, area plans, and specific  
8 plans, zoning, siting and permitting, and transportation planning,  
9 to ensure those decisions do both of the following:

10 (A) Support the goals of the community emissions reduction  
11 program, the local community emissions reduction plan, or both  
12 program and plan, and the environmental justice element.

13 (B) Prevent new, substantial modification or substantial  
14 expanded uses that contribute to poor air quality, as determined  
15 by the community emissions reduction program and the  
16 environmental justice element.

17 (b) (1) Notwithstanding subdivision (a), a local land use agency  
18 may make a land use decision that would serve an essential  
19 environmental, health, or safety need of the community located  
20 within the program area of a community emissions reduction  
21 program or the plan area of a local community emissions reduction  
22 plan that does not align with the program or plan for which there  
23 is no reasonable alternative.

24 (2) (A) Before permitting a use pursuant to paragraph (1), the  
25 local land use agency shall provide notice of, and conduct, a public  
26 meeting in accordance with Section 54953 of the Government  
27 Code. The notice shall include a description of the essential  
28 environmental, health, or safety need of the community being used  
29 to justify the permitting. The local land use agency shall provide  
30 analyses in support of its determination under paragraph (1).

31 (B) Notwithstanding any other law, the public meeting held  
32 pursuant to subparagraph (A) shall not be a special meeting call  
33 pursuant to Section 54956 of the Government Code.

34 (c) (1) (A) A person living in a community with a community  
35 emissions reduction program area or a local community emissions  
36 reduction plan area may seek a review of a land use decision  
37 approved pursuant to subparagraph (B) from the Attorney General  
38 for compliance with that paragraph by filing a petition with the  
39 Attorney General. The Attorney General shall review the

1 ~~challenged decision de novo and may retain independent experts~~  
2 ~~to determine the merits of the petition.~~  
3 ~~(B) The Attorney General may stay the local land use agency~~  
4 ~~decision if the Attorney General finds that the petition makes a~~  
5 ~~prima facie showing that the local land use agency has failed to~~  
6 ~~comply with subdivision (b) in making its decision.~~  
7 ~~(C) If the Attorney General determines that the decision does~~  
8 ~~not comply with subdivision (b), the Attorney General may require~~  
9 ~~the local land use agency to do either of the following:~~  
10 ~~(i) Conduct additional analyses to support its decision made~~  
11 ~~pursuant to subparagraph (B).~~  
12 ~~(ii) Void its decision.~~  
13 ~~(2) A relevant steering committee may refer the additional~~  
14 ~~analysis and its determinations to the Attorney General for~~  
15 ~~certification pursuant to the same procedures as specified in this~~  
16 ~~subdivision.~~  
17 ~~(d) (1) In an action brought by the Attorney General to enforce~~  
18 ~~its determination made pursuant to subdivision (e), a local land~~  
19 ~~use agency that is in violation of this section shall be subject to~~  
20 ~~both of the following remedies:~~  
21 ~~(A) Equitable, injunctive, and declaratory relief, as the court~~  
22 ~~deems appropriate.~~  
23 ~~(B) All costs of investigating and prosecuting the action,~~  
24 ~~including expert fees, reasonable attorney's fees, and costs,~~  
25 ~~whenever the Attorney General prevails.~~  
26 ~~(2) The liability and remedies imposed by this paragraph are in~~  
27 ~~addition to any other liability and remedies imposed by any other~~  
28 ~~law.~~  
29 ~~SEC. 3. Section 44391.7 is added to the Health and Safety~~  
30 ~~Code, to read:~~  
31 ~~44391.7. In addition to any other law, one additional member~~  
32 ~~shall be added to the governing board of a district with a~~  
33 ~~community that is in a location that has been selected for~~  
34 ~~preparation of a community emissions reduction program pursuant~~  
35 ~~to subdivision (e) of Section 44391.2 or a community provided~~  
36 ~~with a grant pursuant to subdivision (d) of Section 44391.2 who~~  
37 ~~is a member of a bona fide environmental justice organization or~~  
38 ~~is a member of a steering committee in the district. The member~~  
39 ~~shall be appointed by state board, in collaboration with the steering~~

1 ~~committee formed pursuant to paragraph (10) of subdivision (c)~~  
2 ~~of Section 44391.2.~~

3 *SEC. 2. Section 44391.6 is added to the Health and Safety*  
4 *Code, to read:*

5 *44391.6. (a) (1) Before approving a commercial or industrial*  
6 *development located on a site of five acres or more, a city,*  
7 *including a charter city, or a county, that includes a location for*  
8 *which an approved community emissions reduction program or*  
9 *local community emissions reduction plan has been prepared shall*  
10 *consider the community emissions reduction program or local*  
11 *community emissions reduction plan or both program and plan.*

12 *(2) (A) For purposes of paragraph (1), “consider” means to*  
13 *analyze the potential air quality impact of local land use approvals,*  
14 *including, but not limited to, siting and permitting, of the industrial*  
15 *or commercial development. The analysis shall do both of the*  
16 *following:*

17 *(i) Identify whether the approval of the commercial or industrial*  
18 *development would further contribute to the poor air quality*  
19 *indicators identified by the board in their analysis of the selected*  
20 *community.*

21 *(ii) Consider adopting applicable measures contained in the*  
22 *community emissions reduction program or local community*  
23 *emissions reduction plan that would mitigate or avoid, to the extent*  
24 *feasible, any further contribution to the poor air quality indicators*  
25 *identified by the state board in its analysis of when selecting the*  
26 *community for the preparation of a community emissions reduction*  
27 *program pursuant to subdivision (c) of Section 44391.2.*

28 *(3) The city or county shall adopt findings supporting its*  
29 *conclusions regarding both elements specified in paragraph (2).*

30 *(4) For projects subject to the California Environmental Quality*  
31 *Act (Division 13 (commencing with Section 21000) of the Public*  
32 *Resources Code), the analysis required pursuant to paragraph (2)*  
33 *may be included with the environmental review pursuant to that*  
34 *act.*

35 *(b) Upon completion of the analysis in subdivision (a) and before*  
36 *approving the commercial or industrial development on a site of*  
37 *five acres or more, the city or county shall present the findings*  
38 *and analyses in support of its conclusion under subdivision (a) at*  
39 *a duly noticed regular meeting of its governing body or planning*  
40 *commission.*

1 (c) *This section does not supersede requirements for, and the*  
2 *legal effects of, general plans, housing elements, zoning*  
3 *ordinances, or other mandates in state law.*

4 ~~SEC. 4.~~

5 *SEC. 3.* Section 44391.8 is added to the Health and Safety  
6 Code, to read:

7 44391.8. The Secretary for Environmental Protection shall  
8 periodically convene representatives of agencies and departments  
9 within the California Environmental Protection Agency to ensure  
10 that coordination among those agencies and departments with  
11 jurisdiction over pollution sources included in a community  
12 emissions reduction program to address concerns raised about  
13 those sources.

14 ~~SEC. 5.~~

15 *SEC. 4.* Section 44391.9 is added to the Health and Safety  
16 Code, to read:

17 44391.9. (a) ~~Notwithstanding Section 10231.5 of the~~  
18 ~~Government Code, on~~ On or before June 30, 2027, and annually  
19 thereafter, the state board shall report to the appropriate  
20 subcommittees of the budget committee of each house of the  
21 Legislature about the progress the state board has made in  
22 implementing Section 44391.2. The report shall include, but is not  
23 limited to, all of the following:

24 (1) The status of implementation of the community emissions  
25 reduction program in each selected community.

26 (2) Best practices.

27 (3) Lessons learned through the implementation of the  
28 community emissions reduction programs or local community  
29 emissions reduction plans.

30 (4) Activities taken to enforce the community emissions  
31 reduction programs and local community emissions reduction  
32 plans.

33 (5) Outcome data that is available, through air monitoring or  
34 other means, including, but not limited to, achieved emissions  
35 reductions.

36 (6) Expenditures made in furtherance of Section 44291.2.

37 (b) A report submitted pursuant to this section shall also be  
38 submitted in compliance with Section 9795 of the Government  
39 Code.

1     ~~SEC. 6.~~

2     *SEC. 5.* No reimbursement is required by this act pursuant to  
3 Section 6 of Article XIII B of the California Constitution because  
4 a local agency or school district has the authority to levy service  
5 charges, fees, or assessments sufficient to pay for the program or  
6 level of service mandated by this act, within the meaning of Section  
7 17556 of the Government Code.

8     However, if the Commission on State Mandates determines that  
9 this act contains other costs mandated by the state, reimbursement  
10 to local agencies and school districts for those costs shall be made  
11 pursuant to Part 7 (commencing with Section 17500) of Division  
12 4 of Title 2 of the Government Code.

O

AMENDED IN SENATE MARCH 25, 2026

**SENATE BILL**

**No. 1159**

---

---

**Introduced by Senator Cabaldon**  
*(Coauthors: Senators Allen, Jones, Ochoa Bogh, and Weber Pierson)*

February 18, 2026

---

---

An act to amend Sections 7920.520, 11405.70, 11500, and 82047 of, and to add ~~Section 17.5 to~~ Sections 11121.5, 11342.575, 11370.1.5, and 54951.5 to, the Government Code, and to amend Section 21066 of the Public Resources Code, relating to artificial intelligence.

LEGISLATIVE COUNSEL'S DIGEST

SB 1159, as amended, Cabaldon. Artificial intelligence: transparency and governance.

The California Constitution provides that people have the right of access to information concerning the conduct of the people's business. Various provisions of existing law, including the California Public Records Act, the Bagley-Keene Open Meeting Act, and the Ralph M. Brown Act, provide, with some exceptions, for public access to government records and meetings of government bodies. Among those acts, the California Public Records Act defines "person" to include any natural person, corporation, partnership, limited liability company, firm, or association.

Existing law, the Political Reform Act of 1974, imposes various requirements and limitations with respect to the conduct of public officials, campaign expenditures and disclosures, political advertisements, lobbying, the ballot pamphlet, and other aspects of political reform. The act defines "person" to mean an individual, proprietorship, firm, partnership, joint venture, syndicate, business trust,

company, corporation, limited liability company, association, committee, and any other organization or group of persons acting in concert.

Existing law, the Administrative Procedure Act, governs, among other things, the procedures for the adoption, amendment, or repeal of regulations by state agencies and for the review of those regulatory actions by the Office of Administrative Law.

Existing law, the California Environmental Quality Act (CEQA), requires a lead agency, as defined, to prepare, or cause to be prepared, and certify the completion of an environmental impact report on a project that it proposes to carry out or approve that may have a significant effect on the environment or to adopt a negative declaration if it finds that the project will not have that effect. CEQA defines “person” to include any person, firm, association, organization, partnership, business, trust, corporation, limited liability company, company, district, county, city and county, city, town, and, among other things, the state.

This bill would specify that, for purposes of the California Public Records Act, the Bagley-Keene Open Meeting Act, the Ralph M. Brown Act, the Political Reform Act of 1974, the Administrative Procedure Act, and CEQA, “person,” “interested person,” “participant,” “member of the public,” as applicable, and any other similar terms under each act referring to those who may engage with governmental agencies, do not include artificial intelligence, as defined, systems, autonomous agents, robots, or other nonhuman entities, whether physical or digital. The bill would make findings and declarations related to these provisions.

The California Constitution requires local agencies, for the purpose of ensuring public access to the meetings of public bodies and the writings of public officials and agencies, to comply with a statutory enactment that amends or enacts laws relating to public records or open meetings and contains findings demonstrating that the enactment furthers the constitutional requirements relating to this purpose.

This bill would make legislative findings to that effect.

Vote: majority. Appropriation: no. Fiscal committee: no.  
State-mandated local program: no.

*The people of the State of California do enact as follows:*

- 1 SECTION 1. (a) (1) Subdivision (b) of Section 3 of Article
- 2 1 of the California Constitution establishes that “the people have

1 the right of access to information concerning the conduct of the  
2 people’s business.” California’s transparency and governance laws,  
3 including the Administrative Procedure Act (Chapter 3.5  
4 (commencing with Section 11340) Chapter 4 (commencing with  
5 Section 11370), Chapter 4.5 (commencing with Section 11400),  
6 and Chapter 5 (commencing with Section 11500) of Part 1 of  
7 Division 3 of Title 2 of the Government Code), the Bagley-Keene  
8 Open Meeting Act (Article 9 (commencing with Section 11120)  
9 of Chapter 1 of Part 1 of Division 3 of Title 2 of the Government  
10 Code), the California Environmental Quality Act (Division 13  
11 (commencing with Section 21000) of the Public Resources Code),  
12 the California Public Records Act (Division 10 (commencing with  
13 Section 7920.000) of Title 1 of the Government Code), the Political  
14 Reform Act of 1974 (Title 9 (commencing with Section 81000)  
15 of the Government Code), and the Ralph M. Brown Act (Chapter  
16 9 (commencing with Section 54950) of Part 1 of Division 2 of  
17 Title 5 of the Government Code), implement this constitutional  
18 mandate by enabling natural persons to participate in and observe  
19 governmental processes.

20 (2) Artificial intelligence (AI) systems can now be programmed  
21 to automatically and continuously engage with governmental  
22 processes at scales and speeds that far exceed human capacity. AI  
23 systems have the ability to submit thousands or millions of  
24 automated public records requests, generate mass public comments  
25 on proposed regulations, file automated petitions for rulemaking,  
26 or otherwise flood governmental agencies with interactions that  
27 simulate human participation but lack genuine human deliberation  
28 or judgment.

29 (3) Automated mass engagement would overwhelm government  
30 agencies, divert limited public resources from serving actual  
31 constituents, drown out genuine human participation, and transform  
32 deliberative processes into meaningless exchanges with machines.  
33 Public comment periods would become ineffective if agencies  
34 must process thousands of AI-generated submissions, and the  
35 administrative burden would undermine the purpose of California’s  
36 transparency laws. This threat is not theoretical. In the United  
37 Kingdom, AI-powered platforms have already enabled automated  
38 generation of planning objections, prompting warnings from  
39 experts that such systems will overwhelm public agencies.

1 (4) California’s transparency and governance laws referenced  
 2 in paragraph (1) presuppose participants who possess  
 3 consciousness, moral agency, deliberative judgment, and  
 4 membership in the political community. AI systems, regardless of  
 5 their sophistication, lack these essential attributes of personhood.  
 6 Consistent with the United States Patent and Trademark Office’s  
 7 November 2025 guidance recognizing that AI systems are tools  
 8 to support human activity rather than independent actors, and with  
 9 the European Union’s AI Act adopted in 2024 protecting the  
 10 fundamental rights of natural persons, California law maintains  
 11 the distinction between human beings and artificial intelligence.

12 (b) Therefore, it is the intent of the Legislature to clarify that,  
 13 for purposes of California’s transparency and governance laws  
 14 referenced in subdivision (a), the terms “person,” “interested  
 15 person,” “member of the public,” and any other similar terms  
 16 referring to those who may engage with governmental agencies  
 17 under those laws, refer to natural persons and legally recognized  
 18 entities capable of genuine participation in democratic governance,  
 19 not AI systems that could be programmed to simulate participation  
 20 at scales that would overwhelm governmental processes.

21 (c) *The changes made by this act are not to be construed to*  
 22 *imply that the terms “person,” “interested person,” “participant,”*  
 23 *“member of the public,” and any other similar terms as used in*  
 24 *any law other than those laws referenced in subdivision (a) include*  
 25 *artificial intelligence systems, autonomous agents, robots, or other*  
 26 *nonhuman entities, whether physical or digital.*

27 ~~SEC. 2. Section 17.5 is added to the Government Code, to read:~~

28 ~~17.5. (a) For purposes of all of the following acts, the terms~~  
 29 ~~“person,” “interested person,” “participant,” “member of the~~  
 30 ~~public,” as applicable, and any other similar terms under each act~~  
 31 ~~referring to those who may engage with governmental agencies,~~  
 32 ~~do not include artificial intelligence systems, autonomous agents,~~  
 33 ~~robots, or other nonhuman entities, whether physical or digital:~~

34 ~~(1) The California Public Records Act (Division 10~~  
 35 ~~(commencing with Section 7920.000) of Title 1):~~

36 ~~(2) The Bagley-Keene Open Meeting Act (Article 9~~  
 37 ~~(commencing with Section 11120) of Chapter 1 of Part 1 of~~  
 38 ~~Division 3 of Title 2):~~

39 ~~(3) The Administrative Procedure Act (Chapter 3.5~~  
 40 ~~(commencing with Section 11340) Chapter 4 (commencing with~~

1 ~~Section 11370), Chapter 4.5 (commencing with Section 11400),~~  
2 ~~and Chapter 5 (commencing with Section 11500) of Part 1 of~~  
3 ~~Division 3 of Title 2).~~

4 ~~(4) The Ralph M. Brown Act (Chapter 9 (commencing with~~  
5 ~~Section 54950) of Part 1 of Division 2 of Title 5).~~

6 ~~(5) The Political Reform Act of 1974 (Title 9 (commencing~~  
7 ~~with Section 81000)).~~

8 ~~(6) The California Environmental Quality Act (Division 13~~  
9 ~~(commencing with Section 21000) of the Public Resources Code).~~

10 ~~(b) For purposes of this section, “artificial intelligence” means~~  
11 ~~an engineered or machine-based system that varies in its level of~~  
12 ~~autonomy and that can, for explicit or implicit objectives, infer~~  
13 ~~from the input it receives how to generate outputs that can influence~~  
14 ~~physical or virtual environments.~~

15 *SEC. 2. Section 7920.520 of the Government Code is amended*  
16 *to read:*

17 7920.520. (a) As used in this division, “person” includes any  
18 natural person, corporation, partnership, limited liability company,  
19 firm, or association.

20 (b) (1) “Person,” “interested person,” “member of the public,”  
21 and any other similar terms referring to those who may engage  
22 with governmental agencies under this division do not include  
23 artificial intelligence systems, autonomous agents, robots, or other  
24 nonhuman entities, whether physical or digital.

25 (2) For purposes of this subdivision, “artificial intelligence”  
26 means an engineered or machine-based system that varies in its  
27 level of autonomy and that can, for explicit or implicit objectives,  
28 infer from the input it receives how to generate outputs that can  
29 influence physical or virtual environments.

30 *SEC. 3. Section 11121.5 is added to the Government Code, to*  
31 *read:*

32 11121.5. (a) As used in this article, “person,” “interested  
33 person,” “participant,” “member of the public,” and any other  
34 similar terms referring to those who may engage with governmental  
35 agencies under this chapter do not include artificial intelligence  
36 systems, autonomous agents, robots, or other nonhuman entities,  
37 whether physical or digital.

38 (b) For purposes of this section, “artificial intelligence” means  
39 an engineered or machine-based system that varies in its level of  
40 autonomy and that can, for explicit or implicit objectives, infer

1 from the input it receives how to generate outputs that can  
2 influence physical or virtual environments.

3 SEC. 4. Section 11342.575 is added to the Government Code,  
4 to read:

5 11342.575. (a) “Person,” “interested person,” “member of  
6 the public,” and any other similar terms referring to those who  
7 may engage with governmental agencies under this chapter do not  
8 include artificial intelligence systems, autonomous agents, robots,  
9 or other nonhuman entities, whether physical or digital.

10 (b) For purposes of this section, “artificial intelligence” means  
11 an engineered or machine-based system that varies in its level of  
12 autonomy and that can, for explicit or implicit objectives, infer  
13 from the input it receives how to generate outputs that can  
14 influence physical or virtual environments.

15 SEC. 5. Section 11370.1.5 is added to the Government Code,  
16 to read:

17 11370.1.5. (a) As used in this chapter, “person” and any other  
18 similar terms referring to those who may engage with governmental  
19 agencies under this chapter do not include artificial intelligence  
20 systems, autonomous agents, robots, or other nonhuman entities,  
21 whether physical or digital.

22 (b) For purposes of this section, “artificial intelligence” means  
23 an engineered or machine-based system that varies in its level of  
24 autonomy and that can, for explicit or implicit objectives, infer  
25 from the input it receives how to generate outputs that can  
26 influence physical or virtual environments.

27 SEC. 6. Section 11405.70 of the Government Code is amended  
28 to read:

29 11405.70. (a) “Person” includes an individual, partnership,  
30 corporation, governmental subdivision or unit of a governmental  
31 subdivision, or public or private organization or entity of any  
32 character.

33 (b) (1) “Person,” “interested person,” “participant,” “member  
34 of the public,” and any other similar terms referring to those who  
35 may engage with governmental agencies under this chapter do not  
36 include artificial intelligence systems, autonomous agents, robots,  
37 or other nonhuman entities, whether physical or digital.

38 (2) For purposes of this subdivision, “artificial intelligence”  
39 means an engineered or machine-based system that varies in its  
40 level of autonomy and that can, for explicit or implicit objectives,

1 *infer from the input it receives how to generate outputs that can*  
2 *influence physical or virtual environments.*

3 *SEC. 7. Section 11500 of the Government Code is amended to*  
4 *read:*

5 11500. In this chapter unless the context or subject matter  
6 otherwise requires:

7 (a) “Agency” includes the state boards, commissions, and  
8 officers to which this chapter is made applicable by law, except  
9 that wherever the word “agency” alone is used the power to act  
10 may be delegated by the agency, and wherever the words “agency  
11 itself” are used the power to act shall not be delegated unless the  
12 statutes relating to the particular agency authorize the delegation  
13 of the agency’s power to hear and decide.

14 (b) “Party” includes the agency, the respondent, and any person,  
15 other than an officer or an employee of the agency in ~~his or her~~  
16 *their* official capacity, who has been allowed to appear or  
17 participate in the proceeding.

18 (c) (1) “Person,” “participant,” and any other similar terms  
19 referring to those who may engage with governmental agencies  
20 under this chapter do not include artificial intelligence systems,  
21 autonomous agents, robots, or other nonhuman entities, whether  
22 physical or digital.

23 (2) For purposes of this subdivision, “artificial intelligence”  
24 means an engineered or machine-based system that varies in its  
25 level of autonomy and that can, for explicit or implicit objectives,  
26 infer from the input it receives how to generate outputs that can  
27 influence physical or virtual environments.

28 ~~(e)~~

29 (d) “Respondent” means any person against whom an accusation  
30 or District Statement of Reduction in Force is filed pursuant to  
31 Section 11503 or against whom a statement of issues is filed  
32 pursuant to Section 11504.

33 ~~(d)~~

34 (e) “Administrative law judge” means an individual qualified  
35 under Section 11502.

36 ~~(e)~~

37 (f) “Agency member” means any person who is a member of  
38 any agency to which this chapter is applicable and includes any  
39 person who ~~himself or herself constitutes~~ *themselves constitute* an  
40 agency.

1 SEC. 8. Section 54951.5 is added to the Government Code, to  
2 read:

3 54951.5. (a) As used in this chapter, “person,” “interested  
4 person,” “participant,” “member of the public,” and any other  
5 similar terms referring to those who may engage with governmental  
6 agencies under this chapter do not include artificial intelligence  
7 systems, autonomous agents, robots, or other nonhuman entities,  
8 whether physical or digital.

9 (b) For purposes of this section, “artificial intelligence” means  
10 an engineered or machine-based system that varies in its level of  
11 autonomy and that can, for explicit or implicit objectives, infer  
12 from the input it receives how to generate outputs that can  
13 influence physical or virtual environments.

14 SEC. 9. Section 82047 of the Government Code is amended to  
15 read:

16 82047. (a) “Person” means an individual, proprietorship, firm,  
17 partnership, joint venture, syndicate, business trust, company,  
18 corporation, limited liability company, association, committee,  
19 and any other organization or group of persons acting in concert.

20 (b) (1) “Person,” “interested person,” “participant,” “member  
21 of the public,” and any similar terms referring to those who may  
22 engage with governmental agencies under this title do not include  
23 artificial intelligence systems, autonomous agents, robots, or other  
24 nonhuman entities, whether physical or digital.

25 (2) For purposes of this subdivision, “artificial intelligence”  
26 means an engineered or machine-based system that varies in its  
27 level of autonomy and that can, for explicit or implicit objectives,  
28 infer from the input it receives how to generate outputs that can  
29 influence physical or virtual environments.

30 SEC. 10. Section 21066 of the Public Resources Code is  
31 amended to read:

32 21066. (a) “Person” includes any person, firm, association,  
33 organization, partnership, business, trust, corporation, limited  
34 liability company, company, district, county, city and county, city,  
35 town, the state, and any of the agencies and political subdivisions  
36 of those entities, and, to the extent permitted by federal law, the  
37 United States, or any of its agencies or political subdivisions.

38 (b) (1) “Person,” “interested person,” “member of the public,”  
39 and any other similar terms referring to those who may engage  
40 with governmental agencies under this division do not include

1 *artificial intelligence systems, autonomous agents, robots, or other*  
2 *nonhuman entities, whether physical or digital.*

3 *(2) For purposes of this subdivision, “artificial intelligence”*  
4 *means an engineered or machine-based system that varies in its*  
5 *level of autonomy and that can, for explicit or implicit objectives,*  
6 *infer from the input it receives how to generate outputs that can*  
7 *influence physical or virtual environments.*

8 ~~SEC. 3.~~

9 *SEC. 11.* The Legislature finds and declares that Section 2 of  
10 this act, which ~~adds Section 17.5 to~~ *amends Section 7920.520 of*  
11 *the Government Code, further, and Section 8 of this act, which*  
12 *adds Section 54951.5 to the Government Code, further, within the*  
13 *meaning of paragraph (7) of subdivision (b) of Section 3 of Article*  
14 *I of the California Constitution, the purposes of that constitutional*  
15 *section as it relates to the right of public access to the meetings of*  
16 *local public bodies or the writings of local public officials and*  
17 *local agencies. Pursuant to paragraph (7) of subdivision (b) of*  
18 *Section 3 of Article I of the California Constitution, the Legislature*  
19 *makes the following findings:*

20 *The clarification made by this act serves the public interest by*  
21 *preserving the integrity and functionality of California’s democratic*  
22 *institutions, preventing automated systems from displacing genuine*  
23 *human participation, protecting public resources from being*  
24 *consumed by responding to machine-generated requests, and*  
25 *ensuring that governmental decisions remain responsive to the*  
26 *people of California.*

O

BOARD MEETING DATE: May 6, 2026

REPORT: Advisory Council

SYNOPSIS: The Advisory Council (Council) held a meeting on Monday, March 16, 2026. The following is a summary of the meeting.

RECOMMENDED ACTION:

This item is provided for the Board's information and awareness; no action is requested at this time.

Dr. Phil Martien, Chair  
Advisory Council

PM:mh

---

Greg Nudd, Deputy Executive Officer of Policy, acting as meeting facilitator, called the meeting to order at 9:01 a.m. This was the first meeting for two new Advisory Council (Council) members (Baldassare and Colburn); the other five members (Carlton, Holm, Martien, Raheja Schmeltz) had been reappointed from the previous Council configuration.

**Roll Call:**

Present: Chairperson Dr. Phil Martien; Vice Chairperson Professor Ann Marie Grover Carlton; and Members Dr. Daniel Baldassare, Melanie Colburn, Dr. Garima Raheja, and Dr. Michael Schmeltz.

Absent: Dr. Stephanie Holm and Board Liaison Lynda Hopkins.

*For additional details of the Advisory Council Meeting, please refer to the webcast, which can be found [here](#). Please use the webcast's index to view specific agenda items.*

**CONSENT CALENDAR**

**2. APPROVAL OF THE DRAFT MINUTES OF THE ADVISORY COUNCIL MEETINGS OF DECEMBER 8, 2025**

Public Comments

No requests received.

Council Comments

None.

Council Action

Prof. Carlton made a motion, seconded by Dr. Martien, to **approve** the Draft Minutes of the Advisory Council Meeting of December 8, 2025; and the motion **carried** by the following vote of the Council:

AYES: Baldassare, Carlton, Martien, Raheja, Schmeltz.  
NOES: None.  
ABSTAIN: None.  
ABSENT: Colburn, Holm, Hopkins.

**ACTION ITEMS**

**3. ELECTION OF OFFICERS**

Mr. Nudd asked the Council to consider electing a Chair and Vice Chair to serve for the duration of the 2026-2027 term.

Public Comments

No requests received.

Council Discussion

None.

Council Action

Prof. Carlton made a motion, seconded by Dr. Raheja, to **appoint** Dr. Martien as Chairperson of the Advisory Council for the duration of the 2026-2027 term; and the motion **carried** by the following vote of the Council:

AYES: Baldassare, Carlton, Martien, Raheja, Schmeltz.  
NOES: None.  
ABSTAIN: None.  
ABSENT: Colburn, Holm, Hopkins.

Dr. Martien made a motion, seconded by Dr. Schmeltz, to **appoint** Prof. Carlton as Vice Chairperson of the Advisory Council for the duration of the 2026-2027 term; and the motion **carried** by the following vote of the Council:

AYES: Baldassare, Carlton, Martien, Raheja, Schmeltz.  
NOES: None.  
ABSTAIN: None.  
ABSENT: Colburn, Holm, Hopkins.

## INFORMATIONAL ITEMS

### 4. OVERVIEW OF THE RALPH M. BROWN ACT

Brian Case, Assistant Counsel, gave the staff presentation *The Ralph M. Brown Act, as Applied to the Advisory Council*, including: topics to be covered; purpose of the Brown Act; are all meetings covered; the noticed agenda; conducting the meeting (loss of quorum, tips for effective meetings, removal for disruptive conduct); conducting the public meeting (public comment); pathways for remote participation (just cause); conduct outside public meetings (email risks, role of staff); and penalties for Brown Act violations.

#### Public Comments

No requests received.

#### Council Comments

The Council and staff discussed requirements (including physical distance, quorum, and just cause participation) for remote teleconferencing participation; how often just cause participation may be utilized by each Council member per calendar year; and whether the Council would have to officially vote on implementing remote teleconferencing locations for its meetings. No action was taken, but the consensus of the Council was to consider utilizing remote locations for future Council meetings.

#### Council Action

No action taken.

### 5. OVERVIEW OF CUMULATIVE IMPACTS WORKPLAN

Continuing the process from the Council's December 8, 2025 meeting, the Council considered making further refinements and additions to the proposed Cumulative Impacts Work Plan, including a newly expanded Appendix B entitled, "The Advisory Council's Interim Findings" (approved July 2024) and "Working Draft Outline for Cumulative Impacts Findings and Recommendations (considered December 2025)," developed by the Work Plan Ad Hoc Subcommittee. Chair Dr. Philip Martien facilitated the Council's discussion, and Air District staff provided feedback for each of the eight Working Draft Outline for Cumulative Impacts Findings and Recommendations.

#### Public Comments

No requests received.

#### Council Discussion

Chair Dr. Philip Martien introduced the workplan as a living document intended to guide development of recommendations to the Air District on how cumulative impacts should be incorporated into agency work. Chair Martien explained that the Council's prior work,

beginning in 2024, narrowed the focus to cumulative impacts in permitting, especially how the Air District might better identify and reduce burdens from new or modified sources of air pollution. The Council discussed the workplan structure, including the background on cumulative impacts and existing Air District activities, methods for developing Council's recommendations, expected work product and timeline, interim key findings, and draft recommendations captured in the appendices. The Council expressed interest in setting a goal to complete a recommendation document during calendar year 2026.

Chair Martien said he would seek volunteers to form an ad hoc committee to help draft the recommendations document; staff and counsel noted that members interested in participating should contact Chair Martien outside the meeting to preserve the ad hoc status under the Brown Act.

Council members continued the discussion on the cumulative impacts workplan with the following major themes:

#### A. Improving impact assessment methods

The Council revisited earlier ideas in Table 1 of the workplan: adding background concentrations into hazard index calculations, because current methods often consider only the incremental emissions from a source and not existing community exposure levels; summing hazards across multiple target organs, drawing on research work conducted by Johns Hopkins University; considering place-based approaches, such as maps (for example, CalEnviroScreen-style approaches), to apply stricter review in overburdened communities; and increasing community representation in assessment and permitting processes.

Staff responded that the Air District had already been planning better air toxics monitoring and modeling, including expanded monitoring and refinery-adjacent community stations, which may help improve background estimates over time. Work is underway with Johns Hopkins University related to the implementation of multi-organ hazard assessment methods, though this will take time. The Air District already applies some place-based permitting protections in high-burden census tracts, and staff are now exploring a more layered approach to enhance community protections.

#### B. Clarifying "uninventoried" and facility-related sources

The Council's discussion clarified that one concern was emissions within the facility fenceline that may not be fully captured in the permitting inventory or risk analysis, such as fugitive emissions, equipment degradation, or other non-routine sources. Staff also noted related community concerns about nearby light industrial operations, dust, and other local sources that may not always be well represented in emission inventories. The Council discussion suggested that some of these issues may be better captured through improved background measurement, more targeted enforcement, facility-wide review, or deeper review under existing rules.

### C. Stressors and health impact assessment

The Council discussed whether factors such as odors, flaring, accidents, or repeated permit violations should be treated as stressors that affect community health and vulnerability, even when they are not easily incorporated into a traditional hazard calculation. Council members also discussed the concept of a Health Impact Assessment, but did not appear strongly supportive of a traditional health impact assessment model if it would be highly resource-intensive without clear practical value in permitting decisions.

### D. Options for reducing cumulative impacts

The Council reviewed Table 2, which focuses on actions to reduce cumulative impacts, including: lower thresholds for requiring best available control technology (BACT) or toxic BACT in overburdened communities, tighter environmental review thresholds, enhanced public engagement, consideration of facility compliance history, limits on near-source PM<sub>2.5</sub> impacts, no-net-increase concepts or caps in overburdened communities, lower risk thresholds, support for existing-facility risk reduction efforts under Rule 11-18, community benefits agreements, and prohibiting some permit types in certain communities.

Staff responded that some of these ideas are already underway or partially reflected in current practices, especially place-based approaches, lower risk thresholds in certain areas, strengthened enforcement, and amendments to Rule 11-18 to improve implementation. Staff indicated they would bring back additional material—especially on the “layered” approach and aspects of the current permitting framework—to support future Council deliberation.

Chair Martien concluded that the discussion was productive and helped refocus the Council on its recommendations and outstanding questions requiring further consideration. As next steps, Council members interested in serving on an ad hoc committee were invited to notify the Chair. The ad hoc committee is expected to meet with staff to begin drafting initial recommendations, document questions and discussion points raised during the meeting, and coordinate with staff to address unresolved items. Chair Martien also indicated that future meetings would benefit from additional information on the layered effect, the permitting process, and updates on existing efforts related to the initial items listed in Table 2.

#### Council Action

No action taken.

### **OTHER BUSINESS**

#### **6. REPORT OF THE EXECUTIVE OFFICER/AIR POLLUTION CONTROL OFFICER (APCO)**

Mr. Nudd waived this item.

**7. PUBLIC COMMENT ON NON-AGENDA MATTERS**

No requests received.

**8. COUNCIL MEMBER COMMENTS**

Council member Colburn asked about the manner in which the Air District interacts with other public agencies.

Chair Martien suggested that Air District staff hold an onboarding for the new Council members.

**9. TIME AND PLACE OF NEXT MEETING**

At the end of the meeting, the next meeting of the Advisory Council was scheduled for Monday, May 4, 2026. After the meeting adjourned, the next meeting of the Advisory Council was scheduled for Monday, June 15, 2026, at 9:00 a.m. The meeting will be held in-person at the Bay Area Metro Center. Members of the public may also attend virtually via webcast.

**ADJOURNMENT**

The meeting was adjourned at 11:24 a.m.

**Attachments**

- #2 – Approval of the Draft Minutes of the Advisory Council Meetings of December 8, 2025
- #3 – Election of Officers
- #4 – Overview of the Ralph M. Brown Act
- #5 – Overview of Cumulative Impacts Workplan

BOARD MEETING DATE: May 6, 2026

REPORT: Community Advisory Council

SYNOPSIS: The Community Advisory Council (CAC) held a meeting on Thursday, March 19, 2026. The following is a summary of the meeting.

RECOMMENDED ACTION:

This item is provided for the Board's information and awareness; no action is requested at this time.

---

## CALL TO ORDER - ROLL CALL

The meeting Facilitator, Randolph Belle of Randolph Belle, Artist (RBA) Creative, called the Community Advisory Council in-person meeting to order at 6:05 p.m.

### Roll Call:

Present, In Person: (Juntos Fruitvale, 3357 International Boulevard, Oakland, CA 94601): Co-Chairs William Goodwin, Patrick Messac, Latasha Washington; and Council Members Dominique Brooks, Adriana Fernandez-Arriaga, Ms. Margaret Gordon, Cynthia Prieto-Diaz, Saidy Reyes Mazariegos, Dominick Ramirez, Kevin G. Ruano Hernandez, Jeff Sanchez, Ken Szutu, and Azjargal Tsogtsaikhan.

Participated Remotely, via Zoom via Section 54953.8.3 of the Ralph M. Brown Act Open Meeting Act (Cal. Gov't Code § 54953.8.3). Remote presence does not count for quorum, but votes are counted for all action items): Council Members Sejal Babaria and Violet Saena (just cause).

Absent: Council Members Arieann Harrison and Harsheet Subedi.

*For additional details of the Community Advisory Council Meeting, please refer to the webcast, which can be found [here](#). Please use the webcast's index to view specific agenda items.*

## 2. PUBLIC COMMENT ON NON-AGENDA MATTERS

No requests received.

## CONSENT CALENDAR

### 3. **REPORT OF THE EXECUTIVE OFFICER/AIR POLLUTION CONTROL OFFICER (APCO)**

On behalf of Dr. Philip M. Fine, Executive Officer/APCO, Arsenio Mataka, Deputy Executive Officer of Equity & Community Programs, gave the following announcements:

- The Air District welcomes two new employees: Temporary Community Advisory Council Designated Officer, Anyania Muse, and Officer of Civil Rights, Kimberly Leefatt.
- On March 12, the Air District opened the grant application period for the People's Air Grant Program, a funding opportunity designed to support projects in impacted communities to reduce exposure to air pollution and address public health. This program was shaped by the CAC - the Board established a one-time allocation of \$3M for the Community Benefit Fund, and the CAC then developed a recommendation for disbursement of those dollars. We are currently working with Council Members Goodwin and Washington to design a process for the People's Air Grant application review panel.
- The Air District's Engineering team has started a taskforce to provide ongoing input on plans to improve the permitting process. The taskforce consists of approximately 15 participants representing different industry sectors, facility sizes, and roles in the permitting process, including representatives from public health organizations and local communities impacted by the Air District's permit decisions. Brian Butler is the staff lead for the taskforce. And Jeff Sanchez is the CAC member now joining the Permitting Taskforce.
- On February 18, the joint enforcement case the Air District brought against Martinez Refining Company (MRC) – together with the Contra Costa District Attorney's Office -- reached a final resolution: a final judgment was signed by Judge Reyes securing a \$10 million civil penalty assessment and compelling MRC to come into compliance during startup and shutdown operations. In total, 163 notices of violation are addressed by this penalty, including the November 2022 spent catalyist release incident.
- The Air District opened over \$90 million in grant funding to support community-driven projects that reduce air pollution, improve health outcomes, and build economic resilience in Benicia, Richmond, and surrounding communities. This funding opportunity is offered through the Air District's Bay REPAIR program (Reinvesting Penalties for Air Improvement and Resilience). Under Bay REPAIR, the Local Community Benefits Fund is now accepting applications through May 2026.

4. **APPROVAL OF THE DRAFT MINUTES OF THE COMMUNITY ADVISORY COUNCIL SPECIAL MEETING OF JANUARY 23, 2026**

Public Comments

No requests received.

Council Comments

None.

Council Action

Council Member Reyes Mazariegos made a motion, seconded by Council Member Washington, to **approve** the Draft Minutes of the Community Advisory Council Special Meeting of January 23, 2026; and the motion **carried** by the following vote of the Council:

AYES: Babaria, Brooks, Fernandez-Arriaga, Gordon, Messac, Prieto-Diaz, Reyes Mazariegos, Ruano Hernandez, Ramirez, Saena, Sanchez, Szutu, Tsogtsaikhan, Washington.  
NOES: None.  
ABSTAIN: None.  
ABSENT: Goodwin, Harrison, Subedi.

Motion Approved.

**ACTION ITEMS**

Item 5 (Community Advisory Council Co-Chair Elections) was about to be presented by Air District staff, when Council Member Messac made a motion, seconded by Council Member Washington, to switch the order of the agenda items, and have presentations and votes for Items 6 (Formation of an Action Plan Ad Hoc Committee for the Community Advisory Council) and 7 (Formation of a Governance Ad Hoc Committee to Amend the Community Advisory Council Charter) come in front of Item 5, to accommodate the late arrival of a Council Member who was to be considered for Item 5. The motion **carried** by the following vote of the Council:

AYES: Babaria, Brooks, Fernandez-Arriaga, Gordon, Messac, Prieto-Diaz, Reyes Mazariegos, Ruano Hernandez, Ramirez, Saena, Sanchez, Szutu, Tsogtsaikhan, Washington.  
NOES: None.  
ABSTAIN: None.  
ABSENT: Goodwin, Harrison, Subedi.

Motion Approved.

**5. FORMATION OF AN ACTION PLAN AD HOC COMMITTEE FOR THE COMMUNITY ADVISORY COUNCIL (OUT OF ORDER, ITEM 6)**

Cynthia Prieto-Diaz, Community Advisory Council Member, gave the presentation *Formation of an Action Plan Ad Hoc Committee of the Community Advisory Council* including: recommended action; why this matters; objective of the Action Plan Ad Hoc committee; Action Plan Ad Hoc Committee procedures; request for Action Plan Ad Hoc members; and recommended action.

This presentation was briefly interrupted so that the Council could take the following action:

Council Member Washington made a motion, seconded by Council Member Sanchez, to hear the presentations (not votes) for Items 6 (Formation of an Action Plan Ad Hoc Committee for the Community Advisory Council) and 7 (Formation of a Governance Ad Hoc Committee to Amend the Community Advisory Council Charter), then hear the staff presentation and vote for Item 5, and then carry out the votes for Items 6 and 7. The motion **carried** by the following vote of the Council:

AYES: Babaria, Brooks, Fernandez-Arriaga, Gordon, Messac, Prieto-Diaz, Reyes Mazariegos, Ruano Hernandez, Ramirez, Saena, Sanchez, Szutu, Tsogtsaikhan, Washington.  
NOES: None.  
ABSTAIN: None.  
ABSENT: Goodwin, Harrison, Subedi.

Motion Approved.

The presentation for Item 6 resumed.

Public Comments

No requests received.

Council Comments

The Council and Air District staff discussed the desire for a mix of newer and veteran members to serve on the on the Action Plan Ad Hoc Committee; who will set the meeting times of the Action Plan Ad Hoc Committee; who determines the maximum number of Council members on the Action Plan Ad Hoc Committee; whether the activities of the Action Plan Ad Hoc Committee are already being accomplished by the Council; focus areas that the Action Plan Ad Hoc Committee will identify; the anticipated timeframe that is to be captured within the Council's Action Plan; whether the Acton Plan will inform Council agenda setting; the request for reports from the ad hoc committee at future Council meetings; and the types of recommendations that the ad hoc committee will be making, and to whom.

NOTED PRESENT: Director Goodwin was noted present at 7:05 p.m.

At this time, after the presentation for Item 6 had concluded, Council Member Washington made a motion, seconded by Council Member Messac, to immediately hear the staff presentation and vote for Item 5, before voting on Items 6 and 7. The motion **carried** by the following vote of the Council:

AYES: Babaria, Brooks, Fernandez-Arriaga, Goodwin, Gordon, Messac, Prieto-Diaz, Reyes Mazariegos, Ruano Hernandez, Ramirez, Saena, Sanchez, Szutu, Tsogtsaikhan, Washington.

NOES: None.

ABSTAIN: None.

ABSENT: Harrison, Subedi.

Motion Approved.

## 6. **COMMUNITY ADVISORY COUNCIL CO-CHAIR ELECTIONS (ITEM 5)**

Lisa Flores, Staff Specialist II, gave the staff presentation *Community Advisory Council Co-Chair Elections*, including: recommended action; background; leadership duties; election process; and sample motion language.

The four Council Members (Goodwin, Messac, Szutu, and Washington) who had expressed interest and submitted applications each gave a brief speech regarding their wish to be considered for one of the three Co-Chair seats.

### Public Comments

No requests received.

### Council Comments

The Council and staff discussed clarification on the voting process; how tied votes would be handled, if any; and what the candidates believe is the Council's greatest challenge.

### Council Action

Each Council Member was then asked by the Clerk to state their three choices out of the four candidates for the three Co-Chair positions, and the Clerk tallied the votes.

**THE COUNCIL RECESSED AT 7:44 P.M AND RESUMED AT 7:57 P.M**

After the break, the Clerk announced the number of votes per each candidate:

Goodwin: 13  
Messac: 13  
Szutu: 9  
Washington: 10

**Based on the Council Members' votes, the three Co-Chairs elected to lead this new Council were: Goodwin, Messac, and Washington.**

At this time the Council revisited Item 6 (Formation of an Action Plan Ad Hoc Committee for the Community Advisory Council). Having already received the presentation and discussed it, the next step was to vote on Council Members that volunteered to serve on the Action Plan Ad Hoc Committee with a limit of four council members joining as Ad Hoc Committee members. The prioritization criteria to be considered was: new Council Members, Council Members that do not serve as Co-Chairs, and Council Members not serving on other ad hoc committees or staff work groups.

At this time, the list of Council Members who volunteered to serve on the Council's Action Plan Ad Hoc Committee were: Babaria, Brooks, Gordon, Ruano-Hernandez, Sanchez, Szutu, and Tsogtsaikhan. (Babaria then volunteered to remove her name from the list.)

#### Council Action

At this time, Co-Chair Messac made a motion, seconded by Council Member Reyes Mazariegos, to refrain from voting on Item 6 (Formation of an Action Plan Ad Hoc Committee for the Community Advisory Council) until first receiving the presentation for and voting for Item 7 (Formation of a Governance Ad Hoc Committee to Amend the Community Advisory Council Charter), and then voting on Item 6. The motion **carried** by the following vote of the Council:

AYES: Babaria, Brooks, Fernandez-Arriaga, Goodwin, Gordon, Messac, Prieto-Diaz, Reyes Mazariegos, Ruano Hernandez, Ramirez, Saena, Sanchez, Szutu, Tsogtsaikhan, Washington.  
NOES: None.  
ABSTAIN: None.  
ABSENT: Harrison, Subedi.

#### **7. FORMATION OF A GOVERNANCE AD HOC COMMITTEE TO AMEND THE COMMUNITY ADVISORY COUNCIL CHARTER**

Amy Smith, Senior Staff Specialist, gave the staff presentation *Formation of a Governance Ad Hoc Committee to Amend the Community Advisory Council Charter*, including: recommended action; purpose and expectations of the Governance Ad Hoc Committee; overview of proposed Charter amendments; process of charter amendments; selection of Governance Ad Hoc Committee members; request for Governance Ad Hoc Committee members; and recommended action.

The final list of Council Members who volunteered to serve on the Council's Governance Ad Hoc Committee were: Prieto-Diaz, Reyes Mazariegos, Ruano Hernandez, and Sanchez.

### Public Comments

No requests received.

### Council Comments

The Council and Air District staff discussed how the Co-Chairs and Governance Ad Hoc Committee will work together to amend the Council's Charter; whether the Board (through its Community Equity, Health, and Justice Committee) will need to approve any amendments to the Council's Charter; when changes to the Council's Charter are to be implemented; whether there is prioritization criteria that pertains to the Governance Ad Hoc Committee; and whether institutional knowledge of the Council is required to serve on this ad hoc committee.

### Council Action

Co-Chair Washington made a motion, seconded by Council Member Sanchez, to **approve** the creation of a Governance Ad Hoc Committee that will develop draft amendments to the Community Advisory Council Charter comprised of the following Council Members: Prieto-Diaz, Reyes Mazariegos, Ruano Hernandez, and Sanchez.

The motion **carried** by the following vote of the Council:

|          |  |
|----------|--|
| AYES:    | Babaria, Brooks, Fernandez-Arriaga, Goodwin, Gordon, Messac, Prieto-Diaz, Reyes Mazariegos, Ruano Hernandez, Ramirez, Saena, Sanchez, Szutu, Tsogtsaikhan, Washington. |
| NOES:    | None.  |
| ABSTAIN: | None.  |
| ABSENT:  | Harrison, Subedi.  |

Motion Approved.

At this time, the Council considered taking action on Item 6. By this time, the list of Council Members who volunteered to serve on the Council's Action Plan Ad Hoc Committee had changed to: Brooks, Gordon, Szutu, and Tsogtsaikhan.

Council Member Gordon made a motion, seconded by Council Member Ruano-Hernandez, to **approve** the creation of an Action Plan Ad Hoc Committee that will develop a plan identifying prioritized areas of focus with measurable benchmarks, to guide actions of the Community Advisory Council, comprised of the following Council Members: Brooks, Gordon, Szutu, and Tsogtsaikhan.

The motion **carried** by the following vote of the Council:

AYES: Babaria, Brooks, Fernandez-Arriaga, Goodwin, Gordon, Messac, Prieto-Diaz, Reyes Mazariegos, Ruano Hernandez, Ramirez, Saena, Sanchez, Szutu, Tsogtsaikhan, Washington.

NOES: None.

ABSTAIN: None.

ABSENT: Harrison, Subedi.

Motion Approved.

## **OTHER BUSINESS**

### **8. COUNCIL MEMBER COMMENTS**

Co-Chair Messac requested that the Council conduct a new case study on Radius Recycling, formerly Schnitzer Steel, in West Oakland, as the facility experienced another fire, on March 11, 2026. Co-Chair Messac said that he believes that case studies can result in swift and direct impact on air quality. He said that he hoped that Air District staff capacity would not be used as a barrier from beginning this work and forming another case study ad hoc committee.

Council Member Gordon added that the fire at Radius Recycling was small and immediately contained. She requested a standing item on future Council agendas during which Council Members can share environmental justice events that are occurring in their communities. It was suggested that Council Members use this standing agenda item: "Council Member Comments and Other Business" to discuss non-agenda items such as local, environmental justice events and updates on issues of community concern.

Council Members Tsogtsaikhan and Fernandez-Arriaga asked whether more ad hoc committees can be created than just the two that were created at this meeting, and the process for doing so. Air District staff suggested that two ad hoc committees is a manageable number and that this can be discussed further with the Co-Chairs.

Council Member Brooks asked whether ad hoc committee meetings may be held virtually. Staff responded that yes, ad hoc committee meetings are not held to the Brown Act and usually meet virtually.

Co-Chair Washington and Council Member Szutu asked about the anticipated duration of the Governance Ad Hoc Committee, and how long ad hoc committees can be active. Staff responded that the CAC Charter states 6 months as the duration of ad hoc committees.

### **9. TIME AND PLACE OF NEXT MEETING**

Thursday, May 21, 2026, at 6:00 p.m. The meeting will be held in-person at the Bay Area Metro Center and at satellite locations as may be specified on the meeting agenda using a remote teleconferencing link. Members of the Community Advisory Council and the

public may attend at any of those in-person locations, and members of the public may also attend virtually via webcast.

### **Adjournment**

The meeting was adjourned at 8:55 p.m.

### **Attachments**

- #4 – Approval of the Draft Minutes of the Community Advisory Council Special Meeting of January 23, 2026
- #5 – Community Advisory Council Co-Chair Elections
- #6 – Formation of an Action Plan Ad Hoc Committee for the Community Advisory Council
- #7 – Formation of a Governance Ad Hoc Committee to Amend The Community Advisory Council Charter

BOARD MEETING DATE: May 6, 2026

REPORT: Stationary Source Committee

SYNOPSIS: The Stationary Source Committee (Committee) held a meeting on Wednesday, April 8, 2026. The following is a summary of the meeting.

RECOMMENDED ACTION:

This item is provided for the Board's information and awareness; no action is requested at this time.

Ken Carlson, Chair  
Stationary Source Committee

KC:mh

---

Stationary Source Committee (Committee) Chairperson, Ken Carlson, called the meeting to order at 10:00 a.m.

**Roll Call:**

Present, In-Person (Bay Area Metro Center, 1st Floor Yerba Buena Room, 375 Beale Street, San Francisco, CA 94105): Chairperson Ken Carlson; and Director Tyrone Jue.

Present, In-Person Satellite Location: (Office of Contra Costa County Supervisor John Gioia Conference Room 11780 San Pablo Ave., Suite D El Cerrito, CA 94530): Directors Gabe Quinto and Steve Young.

Present, In-Person Satellite Location: (San Mateo County Board of Supervisors' Office, 5th Floor, 500 County Center, Redwood City, CA 94063): Directors Rico Medina and Ray Mueller.

Present, In-Person Satellite Location: (Santa Rosa Junior College Campus, Doyle Library, Room 148, 1501 Mendocino Ave., Santa Rosa, CA 95401): Director Lynda Hopkins.

Present, In-Person Satellite Location: (Best Western Plus Hacienda Hotel Old Town, Prado Room, 4041 Harney Street, San Diego, CA 92110): Vice Chairperson John Gioia.

Present, In-Person Satellite Location: (Office of Alameda County Supervisor David Haubert, Scott Haggerty House, 4501, Pleasanton Avenue, Pleasanton, CA 94566): Director David Haubert.

Absent: Directors Dionne Adams and Otto Lee.

For additional details of the Stationary Source Committee Meeting, please refer to the webcast, which can be found [here](#). Please use the webcast's index to view specific agenda items.

## CONSENT CALENDAR

### 3. APPROVAL OF THE DRAFT MINUTES OF THE STATIONARY SOURCE COMMITTEE MEETING OF FEBRUARY 11, 2026

#### Public Comments

No requests received.

#### Committee Comments

None.

#### Committee Action

Director Jue made a motion, seconded by Director Haubert, to **approve** the Draft Minutes of the Stationary Source Committee meeting of February 11, 2026; and the motion **carried** by the following vote of the Committee:

|          |   |
|----------|---|
| AYES:    | Carlson, Gioia, Haubert, Jue, Medina, Mueller, Quinto, Young. |
| NOES:    | None.   |
| ABSTAIN: | None.   |
| ABSENT:  | Adams, Hopkins, Lee.  |

## INFORMATIONAL ITEMS

### 4. CHANGE APPROACH TO AIR QUALITY MANAGEMENT: NEW CLEAN AIR PLAN

Dr. Philip M. Fine, Executive Officer, and Alesia Lau, Principal Environmental Planner, gave the staff presentation *Change Approach to Air Quality Management: New Clean Air Plan*, including: abbreviations; what is a Clean Air Plan; traditional State Implementation Plan (SIP); SIP versus Community Emissions Reduction Plan (CERP); new approach to regional clean air planning; 2017 Clean Air Plan; Air District Strategic Plan commitment – new Clean Air Plan; overview of the new Clean Air Plan; current air quality (ambient monitoring): air quality summary, annual average Particulate Matter (PM)<sub>2.5</sub> trends, disparities in annual average PM<sub>2.5</sub>, 8-hour ozone trends, and annual average benzene trends; regional emissions overview (emissions overview): regional emissions summary, regional emission sources of PM<sub>2.5</sub>, regional emission sources of NO<sub>x</sub> (nitrogen oxides), and regional emission source of reactive organic gases; toxic air contaminants (TAC) overview: TACs, characterizing exposure to TACs, and localized benzene impacts; federal PM planning: status of the Primary Annual PM<sub>2.5</sub> National Ambient Air Quality Standards (NAAQS), Federal Administration actions; and new Clean Air Plan next steps and milestones.

## Public Comments

Public comments were given by Kevin Buchan, Western States Petroleum Association (WSPA); and Kathy Kerridge, Benicia resident.

## Committee Comments

The Committee and Air District staff discussed how to reduce measured concentrations (PM<sub>2.5</sub> and NO<sub>x</sub>) with limited control over contributing factors; whether the Air District has modeled localized impacts for the four designated Bay Area Assembly Bill (AB) 617 communities; a Board member's desire for the banning of residential wood burning, and other Board members' concerns for their constituents who live on unreliable grids and may need to burn wood during emergencies; individual site trends within the annual average PM<sub>2.5</sub> trends chart; potential repercussions, if the Air District enforces standards that exceed federal or state standards; whether the highest design values within the annual average PM<sub>2.5</sub> trends chart are due to an absence of wildfires; mobile off-road sources (ships) activity, as a source of NO<sub>x</sub>, and whether docked ships emit more emissions than moving ships; the importance of analyzing local impacts of PM<sub>2.5</sub>, besides regional impacts; the desire for the Air District to engage in maritime emissions regulation and work with impacted ships and manufacturers, even though mobile sources are outside of the Air District's authority; current localized monitoring technology and how it will be improved; long-term attainment goal next steps; and whether the Air District may set its own attainment levels, beyond federal requirements and standards.

## Committee Action

No action taken.

## **5. OVERVIEW OF REFINERY FLARING, FLARING MINIMIZATION EFFORTS AND THE DEVELOPMENT OF "FLARING 101"**

Katie Gong, Senior Air Quality Engineer, gave the staff presentation *Overview of Refinery Flaring, Flaring Minimization Efforts and the Development of "Flaring 101*, including: abbreviations; outline; what is a flare system; when does flaring occur; flare types; visual cues of properly operated non-hydrogen flare; current rule requirements; other regulations; Bay Area flaring trends; impetus of rule development efforts; current status of rule development efforts; Refinery Technical Working Group (RTWG); Flaring 101: what is Flaring 101, and next steps; potential rule amendment concepts: goals for potential amendment concepts, Goal #1 - Flare Minimization Plans (FMPs) and Reporting and Monitoring Requirements, 1.1. Strengthen FMP Updates, 1.2. Standardize Reporting Requirements, 1.3. Expand Definitions and Categories for Reporting Causes of Flaring, 1.4. Strengthen Monitoring and Reporting Requirements, Goal #2 - Reduce Flaring Emissions and Frequency, 2.1. Incorporate Key Requirements from United States Environmental Protection Agency (US EPA) Refinery Sector Rule for Flares, 2.2. Establish New Annual Flare Limits, 2.3. Require Mitigation Measures for Violations, 2.4. Require Submittal of Causal Reports based on Additional Triggers, and 2.5. Require Third-Party Audits for Facilities; and Concept Paper next steps.

## Public Comments

Public comments were given by Morgan Zellers, Phillips 66; Kevin Buchan, WSPA; Kaitlin Alcontin, Communities for a Better Environment; Todd Osterberg, Chevron; and Brandon Sutter, Chevron.

## Committee Comments

The Committee and Air District staff discussed concerns about planned flaring events, and the desire for notification well beforehand; how utility power outages may affect flaring events; whether petroleum refineries are investing in backup power systems for emergencies; how often flaring events occur at refineries; how often the RTWG meets and the desire for that body to discuss flaring at every meeting; the desire that the Board would have more collaborative relationships with the refineries about flaring; concerns about putting controls on safety-related flaring events; how often flaring events are beyond the refineries' control; the suggestion of implementing a fast-track process for permitting backup generators during power outages; the difference between mitigation fees and enforcement fees; what emissions are released during flaring events; third party audits; the suggestion of analyzing planned flaring events, versus emergency flaring events, to see how both type of events can be/have been reduced; concerns about mitigation fees, training costs, and data acquisition costs; and health and emotional impacts on the public from flaring events.

## Committee Action

No action taken.

## **OTHER BUSINESS**

### **6. PUBLIC COMMENT ON NON-AGENDA MATTERS**

No requests received.

### **7. COMMITTEE MEMBER COMMENTS**

None.

### **8. TIME AND PLACE OF NEXT MEETING**

Wednesday, May 13, 2026, at 10:00 a.m. The meeting will be held in-person at the Bay Area Metro Center and at satellite locations as may be specified on the meeting agenda using a remote teleconferencing link. Members of the Stationary Source Committee and the public may attend at any of those in-person locations, and members of the public may also attend virtually via webcast.

The meeting was adjourned at 12:42 p.m.

## Attachments

- #3 –Approval of the Draft Minutes of the Stationary Source Committee Meeting of February 11, 2026
- #4 – Change Approach to Air Quality Management: New Clean Air Plan
- #5 – Overview of Refinery Flaring, Flaring Minimization Efforts and the Development of "Flaring 101"

BOARD MEETING DATE: May 6, 2026

REPORT: Community Equity, Health, and Justice Committee

SYNOPSIS: The Community Equity, Health, and Justice Committee (Committee) held a meeting on Wednesday, April 8, 2026. The following is a summary of the meeting.

RECOMMENDED ACTION:

This item is provided for the Board's information and awareness; no action is requested at this time.

John Gioia, Chair  
Community Equity, Health, and Justice Committee

JG:mh

---

Community Equity, Health, and Justice (Committee) Chairperson, John Gioia, called the meeting to order at 1:17 p.m.

**Roll Call:**

Present, In-Person (Bay Area Metro Center, 375 Beale Street, 1<sup>st</sup> Yerba Buena Room, San Francisco, CA, 94105): Directors Monica Brown and Linda Sell.

Present, In-Person Satellite Location: Napa County Administration Building, 1195 Third Street, Suite 310, Crystal Conference Room, Napa, CA 94559): Director Joelle Gallagher.

Present, In-Person Satellite Location: (Office of Contra Costa County Supervisor John Gioia, Conference Room, 11780 San Pablo Ave., Suite D, El Cerrito, CA 94530): Director Steve Young.

Present, In-Person Satellite Location: (Best Western Plus, Hacienda Hotel Old Town, Prado Room, 4041 Harney Street, San Diego, CA 92110): Chairperson John Gioia.

Absent: Vice Chairperson Dionne Adams; and Director Shamann Walton.

*For additional details of the Community Equity, Health, and Justice Committee Meeting, please refer to the webcast, which can be found [here](#). Please use the webcast's index to view specific agenda items.*

## CONSENT CALENDAR

### 3. **APPROVAL OF THE DRAFT MINUTES OF THE COMMUNITY EQUITY, HEALTH, AND JUSTICE COMMITTEE MEETING OF MARCH 11, 2026**

#### Public Comments

No requests received.

#### Committee Comments

None.

#### Committee Action

Director Sell made a motion, seconded by Director Brown, to **approve** the Draft Minutes of the Community Equity, Health, and Justice Committee Meeting of March 11, 2026; and the motion carried by the following vote of the Committee:

AYES: Brown, Gioia, Gallagher, Sell, Young.  
NOES: None.  
ABSTAIN: None.  
ABSENT: Adams, Walton.

## ACTION ITEM

### 4. **RECOMMENDATIONS TO STRENGTHEN COLLABORATION BETWEEN THE BOARD OF DIRECTORS AND THE COMMUNITY ADVISORY COUNCIL (CAC)**

Community Advisory Council Co-Chairs William Goodwin and Latasha Washington, along with Arsenio Mataka, Deputy Executive Officer of Equity and Community Programs, gave the presentation *Recommendations to Strengthen Collaboration between the Board of Directors and Community Advisory Council*, including: recommended action; Purpose of Increasing Board and CAC Communication & Collaboration; Recap from the January 28, 2026 Board of Directors Retreat; CAC Recommendations to the Board; Air District response; CAC Recommendations to the Board; and recommended action.

*Note: The Community Advisory Council adopted these recommendations at its meeting on November 20, 2025. The recommendations were also discussed at the Board retreat on January 28, 2026.*

#### Public Comments

Public comments were given by Arieann Harrison, CAC member.

#### Committee Comments

The Committee and staff discussed whether other air districts in California have designated members of the public/environmental justice advocates appointed to their governing Boards; the suggestion of having Air District staff coordinate meet and greet meetings between

Council Members and Board members representing their geographical area; the Board members' interest in having Council Member liaisons participate in Board and/or standing committee meetings as non-voting guests in the discussions, whether the Council Members would count for the meeting quorum, and the suggestion of rotating the guest Council Members; how organizing joint Board/Council retreats may strain Air District staff resources; the suggestion that items designated for joint discussion by the Board and Council be prioritized at the beginning of the agenda/morning session; and the perception that the Council is too segregated from the Board with limited access.

#### Committee Action

Director Gallagher made a motion, seconded by Director Sell, to recommend the Board *consider the Community Advisory Council's recommendations and staff's responses to the recommendations, and consider providing potential direction to staff*, and the motion carried by the following vote of the Committee:

AYES: Brown, Gallagher, Gioia, Sell, Young.  
NOES: None.  
ABSTAIN: None.  
ABSENT: Adams, Walton.

#### INFORMATIONAL ITEM

##### **5. MARIE HARRISON ENVIRONMENTAL JUSTICE SCHOLARSHIP PROGRAM UPDATE**

Ariann Harrison, Founder and Executive Director of the Marie Harrison Community Foundation, and Daniel S. Madrigal, Senior Staff Specialist, gave the presentation *Marie Harrison Environmental Justice Scholarship Program Update*, including: Marie Harrison Community Foundation; Marie Harrison; scholarship goals and criteria; review of 2025 scholarships; 2025 scholarships winners; and Marie Harrison Environmental Justice Scholarship Year 4.

#### Public Comments

No requests received.

#### Committee Comments

The Committee and staff discussed the desire for clarification on eligibility criteria, specifically regarding impacted neighborhoods in which applicants reside.

#### Committee Action

No action taken.

## **OTHER BUSINESS**

### **6. PUBLIC COMMENT ON NON-AGENDA MATTERS**

Public comments were given by Malik Washington.

### **7. COMMITTEE MEMBER COMMENTS**

None.

### **8. REPORT OF THE DEPUTY EXECUTIVE OFFICER OF EQUITY AND COMMUNITY PROGRAMS**

Arsenio Mataka, Deputy Executive Officer of Equity and Community Programs, made the following announcements:

- On March 12, the Air District opened the grant application period for the People's Air Grant Program, a funding opportunity designed to support projects in impacted communities to reduce exposure to air pollution and address public health. This program was shaped by the CAC - the Board established a one-time allocation of \$3M for the Community Benefit Fund, and the CAC then developed a recommendation for disbursement of those dollars.
- At the next Community Equity, Health, and Justice Committee meeting, Air District staff will provide an update on the Community Investments Office's Local Community Benefits Fund, which supports community-driven projects that reduce air pollution, improve health outcomes, and build economic resilience for a just transition away from the harmful effects of a fossil-fuel economy. Applications are now open for Round 1, which will distribute funds in Benicia, Richmond, and surrounding communities.

### **9. TIME AND PLACE OF NEXT MEETING**

Wednesday, May 13, 2026, at 1:00 p.m. The meeting will be held in-person at the Bay Area Metro Center and at satellite locations as may be specified on the meeting agenda using a remote teleconferencing link. Members of the Community Equity, Health, and Justice Committee and the public may attend at any of those in-person locations, and members of the public may also attend virtually via webcast.

The meeting was adjourned at 2:23 p.m.

### **Attachments**

- #3 – Approval of the Draft Minutes of the Community Equity, Health, and Justice Committee Meeting of March 11, 2026
- #4 – Recommendations to Strengthen Collaboration Between the Board of Directors and the Community Advisory Council
- #5 – Marie Harrison Environmental Justice Scholarship Program Update

BOARD MEETING DATE: May 6, 2026

REPORT: Finance and Administration Committee

SYNOPSIS: The Finance and Administration Committee (Committee) held a meeting on Wednesday, April 15, 2026. The following is a summary of the meeting.

RECOMMENDED ACTION:

This item is provided for the Board's information and awareness; no action is requested at this time.

Lynda Hopkins, Chair  
Finance and Administration Committee

LH:mh

---

Finance and Administration Committee Vice Chairperson, Juan González III, called the meeting to order at 1:00 p.m.

**Roll Call:**

Present, In-Person (Bay Area Metro Center, 375 Beale Street, 1<sup>st</sup> Floor Board Room, San Francisco, CA, 94105): Vice Chairperson Juan González; and Director Tyrone Jue.

Present, In-Person Satellite Location: (Office of Alameda County Supervisor David Haubert, Scott Haggerty House, 4501 Pleasanton Avenue, Pleasanton, CA 94566): Director Haubert.

Present, In-Person Satellite Location: (Sunnyvale City Hall, Cedar Conference Room, 456 W. Olive Ave., Sunnyvale, CA 94086): Director Linda Sell.

Present, In-Person Satellite Location: (San Mateo County Board of Supervisors' Office, 5th Floor, 500 County Center, Redwood City, CA 94063): Director Noelia Corozo.

Present, In-Person Satellite Location: (Santa Rosa Junior College Campus, Doyle Library, Room 148, 1501 Mendocino Ave., Santa Rosa, CA 95401): Chairperson Lynda Hopkins.

Present, In-Person Satellite Location: (Palo Alto City Hall, Community Meeting Room, 250 Hamilton Ave., Palo Alto, CA 94301): Director Vicki Veenker.

Absent: Director Brian Colbert.

*For additional details of the Finance and Administration Committee Meeting, please refer to the webcast, which can be found [here](#). Please use the webcast's index to view specific agenda items.*

## CONSENT CALENDAR

### 3. APPROVAL OF THE DRAFT MINUTES OF THE FINANCE AND ADMINISTRATION COMMITTEE MEETING OF MARCH 18, 2026

#### Public Comments

No requests received.

#### Committee Comments

None.

#### Committee Action

Director Jue made a motion, seconded by Director Veenker, to **approve** the Draft Minutes of the Finance and Administration Committee Meeting of March 18, 2026; and the motion carried by the following vote of the Committee:

AYES: Corzo, González, Haubert, Hopkins, Jue, Sell, Veenker.  
NOES: None.  
ABSTAIN: None.  
ABSENT: Colbert.

## INFORMATIONAL ITEM

### 4. PERMITTING STRATEGIES

Pamela Leong, Engineering Division Director, gave the staff presentation *Permitting Strategies*, including: outcome; outline; background: Strategic Plan Goal 4 (Be Effective Accountable, and Customer-Oriented), plan acceleration and support, recent metrics (in versus out, active applications, Health Risk Assessments in queue), backlog reduction goal; progress on plan implementation: plan progress, recap of important actions, staffing actions, recent actions (policy/program updates, tracking tools), new tools to analyze permitting bottlenecks; application rework and flow, application overdue and backlog flows); and next steps: Permitting and Compliance System upgrades, tracking tools, policy/program updates, resource management.

#### Public Comments

Public comments were given by Peter Okurowski, California Council for Environmental & Economic Balance.

#### Committee Comments

The Committee and staff discussed concerns about the maintenance level with complex permit applications deadline of 2029, and the desire for a more aggressive timeline; the request for more frequent interim status updates to the Committee/Board; appreciation for the corrective action and progress thus far; and ways in which the Air District is measuring efficiency and transparency in the Air District's permitting strategies.

Committee Action

No action taken.

**ACTION ITEM**

**5. PROPOSED AMENDMENTS TO AIR DISTRICT REGULATION 3: FEES**

Fred Tanaka, Engineering Manager, and Mark Gage, Principal Air Quality Engineer, gave the staff presentation *Proposed Fee Regulation Amendments*, including: recommended action; outline; cost recovery background: limitations, trends, trends example; cost recovery strategies; cost recovery background; fee reductions; fee removals; proposed fee regulation amendments; other proposed changes – general, new fee, reclassification; impact on large facilities – permit renewal; impact on small facilities – permit renewal; fee reduction summary; efficiencies and cost containment efforts; budget & fee regulation schedule; and recommended action.

Public Comments

Public comments were given by Bob Brown, Western States Petroleum Association.

Committee Comments

The Committee and staff discussed why the Air District doesn't bill staff time to individual permits or facilities and suggested tracking similar to law-firm type billing; whether staff is working with industry to identify cost-saving measures and incentives to help reduce fees while pursuing cost recovery; discussed seeing timing/effort breakdowns would be instructive; praise for dashboards and Key Performance Indicator (KPIs) improving transparency and trust; whether permitting streamlining includes creating objective, upfront standards and expectations for regulated facilities, to reduce back-and-forth correspondence; discussed eliminating delinquency fee to reduce administrative burden for small businesses and reasons for this higher cost; and whether process improvements could reduce delinquencies; review of slide *Impact on Large Facilities – Permit Renewal* and to confirm definition and comparison between predicted and actual fee changes.

Committee Action

Director Jue made a motion, seconded by Director Haubert, to recommend that the Board **adopt** the proposed Fee Regulation Amendments; and the motion carried by the following vote of the Committee:

AYES: Corzo, González, Haubert, Hopkins, Jue, Sell, Veenker.  
NOES: None.  
ABSTAIN: None.  
ABSENT: Colbert.

## INFORMATIONAL ITEM

### **6. FINANCIAL AUDIT REPORT FOR FISCAL YEAR ENDING 2025**

*Pursuant to Section 9.2 of the Administrative Code, the Air District is required to undergo an independent financial audit annually. The Committee will review the audited financial statements and related reports for the fiscal year ending June 30, 2025, prepared by Simpson & Simpson, LLP. The audit was conducted in accordance with Government Auditing Standards issued by the Comptroller General of the United States, as well as Office of Management and Budget Circular A-133, which establishes federal audit requirements for entities that expend federal funds.*

Joseph Moussa of Air District audit partner, Simpson & Simpson LLP, gave the presentation Fiscal Year 2025 Bay Area Air Quality Management District Presentation of Audit Results, including: agenda; Auditor's required communications regarding Statement on Auditing Standards (SAS) No. 114; audit results and highlights of the basic financial statements; and audit results and highlights of the single audit.

#### Public Comments

No requests received.

#### Committee Comments

The Committee and staff discussed the timeline of the audit planning and verification of completion of personnel-related recommendations, and whether that will be reported at the next audit review; what would reduce the audit workload; discussed how to accelerate the audit timeline; the importance of timely audit opinions to access past performance; and asked for audit timeline comparison to corporate audits.

#### Committee Action

No action taken.

## **OTHER BUSINESS**

### **7. PUBLIC COMMENT ON NON-AGENDA MATTERS**

No requests received.

### **8. COMMITTEE MEMBER COMMENTS**

None.

### **9. TIME AND PLACE OF NEXT MEETING**

Wednesday, May 20, 2026, at 1:00 p.m. The meeting will be held in-person at the Bay Area Metro Center and at satellite locations as may be specified on the meeting agenda using a remote teleconferencing link. Members of the Finance and Administration

Committee and the public may attend at any of those in-person locations, and members of the public may also attend virtually via webcast.

**Adjournment**

The meeting was adjourned at 2:33 p.m.

**Attachments**

- #3 – Approval of the Draft Minutes of the Finance and Administration Committee Meeting of March 18, 2026
- #4 – Permitting Strategies
- #5 – Proposed Amendments to Air District Regulation 3: Fees
- #6 – Financial Audit Report for Fiscal Year Ending 2025

BOARD MEETING DATE: May 6, 2026

REPORT: Policy, Grants, and Technology Committee

SYNOPSIS: The Policy, Grants, and Technology Committee (Committee) held a meeting on Wednesday, April 15, 2026. The following is a summary of the meeting.

RECOMMENDED ACTION:

This item is provided for the Board's information and awareness; no action is requested at this time.

Vicki Veenker, Chair  
Policy, Grants, and Technology Committee

VV:mh

---

Policy, Grants, and Technology Committee (Committee) Chairperson, Vicki Veenker, called the meeting to order at 10:11 a.m.

**Roll Call:**

Present, In-Person (Bay Area Metro Center, 375 Beale Street, 1<sup>st</sup> Floor Board Room, San Francisco, CA, 94105): Chairperson Vicki Veenker; and Vice Chairperson Juan González III.

Present, In-Person Satellite Location: (Napa County Administration Building, 1195 Third Street, Suite 310, Crystal Conference Room, Napa, CA 94559): Director Joelle Gallagher.

Present, In-Person Satellite Location: (San Mateo County Board of Supervisors Offices, 500 County Center, 5th Floor, Redwood City, CA 94063): Director Noelia Corzo and Director Ray Mueller.

Present, In-Person Satellite Location: (City of San Bruno, 567 El Camino Real, Room 138, San Bruno, CA 94066): Director Rico E. Medina.

Absent: Directors Margaret Abe-Koga, Ken Carlson, Brian Colbert, Mark Salinas, Lena Tam.

*For additional details of the Policy, Grants, and Technology Committee Meeting, please refer to the webcast, which can be found [here](#). Please use the webcast's index to view specific agenda items.*

## CONSENT CALENDAR

### 3. APPROVAL OF THE DRAFT MINUTES OF THE POLICY, GRANTS, AND TECHNOLOGY COMMITTEE MEETING OF MARCH 18, 2026

#### Public Comments

No requests received.

#### Committee Comments

None.

#### Committee Action

Vice González made a motion, seconded by Director Medina, to **approve** the Draft Minutes of the Policy, Grants, and Technology Committee Meeting of March 18, 2026; and the motion carried by the following vote of the Committee:

AYES: Corzo, Gallagher, González, Medina, Mueller, Veenker.  
NOES: None.  
ABSTAIN: None.  
ABSENT: Abe-Koga, Carlson, Colbert, Salinas, Tam.

## ACTION ITEMS

### 4. STATE LEGISLATIVE UPDATES

Alan Abbs, Legislative Officer, gave the staff presentation *State Legislative Updates*, including: abbreviations; recommended action; 2026 Legislative Session; Board-approved-position bills – Senate Bill (SB) 222 (Wiener), Assembly Bill (AB) 907 (Chen), and AB 1777 (Garcia), AB 2313 (Berman), SB 299 (Cabaldon), SB 954 (Blakespear), AB 1791 (Sanchez), AB 2752 (Avila Farias), SB 1392 (Cortese); Air District staff recommendations - AB 2057 (DeMaio), AB 2102 (DeMaio), AB 2349 (Solache), SB 1039 (Grove), SB 1075 (Reyes), SB 1159 (Cabaldon); additional bills for discussion – AB 2635 (C. Rodriguez); and recap of recommended action.

#### Public Comments

No requests received.

#### Committee Comments

The Committee and Air District staff discussed the following points regarding the following bills:

- AB 2349 – the current air quality incident response protocol between California air districts and the California Air Resources Board, and concerns about introducing unnecessary administrative complexity

- AB 2635 – concerns that the bill would create a requirement to create a lawn and garden rebate program without funding to support the implementation
- SB 1039 – the marginal cost or operational impact of extending current monitoring to additional pollutants
- Whether the Air District would take a position on AB 899 (Grove) - Fire prevention: Wildfire and Forest Resilience Task Force: wildfire smoke.

Committee Action

Vice Chair González made a motion, seconded by Director Corzo, to recommend the Board adopt positions on the following pending state legislative bills based on Air District staff recommendations:

**SUPPORT**

*Assembly Bill 2349 (Solache)*  
*Senate Bill 1159 (Cabaldon)*

**OPPOSE**

*Assembly Bill 2057 (DeMaio)*  
*Assembly Bill 2102 (DeMaio)*  
*Senate Bill 1039 (Grove)*  
*Senate Bill 1075 (Reyes)*

Director Mueller initially abstained, however, upon further discussion, he requested that the minutes reflect that he would amend his vote to YES as a courtesy to his colleagues on the committee in order to advance the recommendation to the full Board at the May 6, 2026 meeting.

Therefore, the motion carried by the following vote of the Committee:

AYES: Corzo, Gallagher, González, Medina, Mueller, Veenker.  
 NOES: None.  
 ABSTAIN: None.  
 ABSENT: Abe-Koga, Carlson, Colbert, Salinas, Tam.

**5. TRANSPORTATION FUND FOR CLEAN AIR (TFCA) 40% FUND ALLOCATION AND EXPENDITURE PLANS FOR FISCAL YEAR ENDING (FYE) 2027**

Jason Newman, Staff Specialist, gave the staff presentation, *Transportation Fund for Clean Air 40% Fund Allocation and Expenditure Plans for Fiscal Year Ending 2027*, including: recommendations; TFCA; project types funded in previous years; new: additional allocation; why bikeways and bike parking; proposed additional bikeway allocation; proposed expenditure plan for counties in FYE 2027; and recommendations.

Public Comments

No requests received.

Committee Comments

The Committee and Air District staff discussed how the proposed additional bikeway allocation base amount of \$1M for each county was calculated; eligible uses for TFCA

funds; the TFCA 60% Fund Account of \$19.3 Million; appreciation for adding bikeways projects; and the reason for the amount of reconciliation and reprogrammed TFCA funds for Alameda County.

Committee Action

Vice Chair González made a motion, seconded by Director Corzo, to recommend the Board take the following actions:

1. Approve the proposed allocation and expenditure plans for the estimated new Transportation Fund for Clean Air revenue to each of the nine Administering Agencies for Fiscal Year Ending 2027 that will be funded by the 40% portion of the Transportation Fund for Clean Air fund;
2. Approve the proposed allocation of additional funding for bikeway and bike parking projects to each of the nine Administering Agencies for Fiscal Year Ending 2027 that will be funded by prior years' revenue under the 60% portion of Transportation Fund for Clean Air fund; and
3. Authorize the Executive Officer/Air Pollution Control Officer to enter into funding agreements with the Administering Agencies for Transportation Fund for Clean Air revenues to be programmed in FYE 2027.

The motion carried by the following vote of the Committee:

AYES: Corzo, Gallagher, González, Medina, Mueller, Veenker.  
NOES: None.  
ABSTAIN: None.  
ABSENT: Abe-Koga, Carlson, Colbert, Salinas, Tam.

**OTHER BUSINESS**

**6. PUBLIC COMMENT ON NON-AGENDA MATTERS**

No requests received.

**7. COMMITTEE MEMBER COMMENTS**

None.

**8. TIME AND PLACE OF NEXT MEETING**

Wednesday, May 20, 2026, at 10:00 a.m. The meeting will be held in-person at the Bay Area Metro Center and at satellite locations as may be specified on the meeting agenda using a remote teleconferencing link. Members of the Policy, Grants, and Technology Committee and the public may attend at any of those in-person locations, and members of the public may also attend virtually via webcast.

**Adjournment**

The meeting was adjourned at 11:18 a.m.

### Attachments

- #3 - Approval of the Draft Minutes of the Policy, Grants, and Technology Committee Meeting of March 18, 2026
- #4 – State Legislative Updates
- #5 – Transportation Fund for Clean Air 40% Fund Allocation and Expenditure Plans for Fiscal Year Ending 2027

**BAY AREA AIR DISTRICT**  
Memorandum

To: Chairperson Lynda Hopkins and Members  
of the Board of Directors

From: Philip M. Fine  
Executive Officer/APCO

Date: May 6, 2026

Re: Rule 9-6 Regulatory Overview and Discussion of Flexibility and Affordability  
Amendments for Zero-NOx Water Heaters

RECOMMENDED ACTION

Discuss and provide input on staff recommendations or alternative approaches.

BACKGROUND

In March 2023, the Bay Area Air District Board of Directors adopted amendments to Regulation 9, Rule 6 (Rule 9-6) that established a zero nitrogen oxides (NOx) emissions standard for all sales and installations of covered water heaters beginning with those manufactured after January 1, 2027. These amendments did not include any flexibilities or exemptions for any potential extenuating circumstances. Over the past two years, Air District Staff have collaborated with stakeholders to develop and refine potential amendments to introduce flexibility into the zero NOx standard, with the intention of easing requirements and potential cost impacts and provide options for an easier transition.

The Air District convened an external Implementation Working Group (IWG) comprised of over 40 members representing a variety of stakeholder segments to identify and compile potential solutions for implementation barriers. The IWG's focus areas included technology readiness, costs, permitting, workforce, grid capacity, and equitable access to incentives and financing. Over 20 IWG meetings were held between May 2023 and August 2024 that informed staff's December 2024 Board update and subsequent October 2025 preliminary concepts paper for flexibility and affordability amendments.

## DISCUSSION

### **Flexibility Amendments**

While the long-term benefits of Rule 9-6 remain clear, stakeholder engagement has highlighted several practical challenges that can significantly increase costs or limit implementation feasibility for certain properties. Air District Staff are recommending that the Board of Directors provide direction to move forward with a proposal for further amendments to Rule 9-6 that would provide flexibility in the following scenarios:

- Challenging installations due to space constraints, existing electrical system or panel upgrades.
- Low-income qualified property owners
- Water heaters with a capacity of less than 30 gallons
- Hydronic systems (combined water and space heating)
- Businesses with high-heat demand (examples: restaurants, healthcare, dry cleaners, etc.)
- Temporary emergency gas water heaters installed by certified contractors

Air District staff estimate that the average incremental cost to install a heat pump water heater for a “standard” project is approximately \$3,500. Of this, the incremental retail cost of a heat pump water heater as compared to a new natural gas fired unit ranges from \$600 - \$1,600. The remaining difference is due to additional labor costs to install the zero NOx unit.

Air District staff estimate up to 38 percent of new water heater installations would qualify for exemptions as described above. Income-based eligibility exemptions for low-income or housing cost burdened property owners would account for approximately 18 percent, while project or building constraints, such as space or electrical limitations, would account for the other 20 percent. Given the technical nature of the project-specific exemptions, some participation from licensed contractors would be required.

In order to provide sufficient time to make necessary project-specific upgrades while still ensuring that emission reductions are achieved over time, staff recommend that project-specific exemptions be granted on a *one-time basis* per address or location. For water heaters less than 30 gallons and hydronic units, staff recommend amending the compliance date to January 1, 2031 to allow for more time for market development and for the IWG to further evaluate technology readiness and costs at the appropriate time.

Air District staff plans to provide a website for property owners to request and immediately receive exemptions through a process that is as fast and seamless as possible and ensures that rule requirements are met.

The rule will continue to deliver meaningful regional air quality benefits, particularly through reductions in fine particulate matter (PM2.5). However, the introduction of exemptions will result in a more gradual realization of emissions reductions. Over time, as exempted properties transition to compliant technologies, the full benefits of the rule will be achieved.

### **Common Questions and Concerns**

Throughout the stakeholder engagement process, Air District Staff have received some common questions regarding the implementation of Rule 9-6 and potential flexibility amendments including:

- **Scope:** Rules 9-4 and 9-6 apply specifically to furnaces and water heaters. The rules do not impose requirements on other household appliances such as stoves or clothes dryers, as the rules are focused on reducing NOx emissions from major sources.
- **Equity and Affordability:** Equity considerations are central to the proposed amendments. The combination of targeted exemptions and available incentives is intended to reduce financial burdens, particularly for low-income and cost-burdened households. Staff intend to direct all interested parties towards available rebates to support equitable education and access.
- **Electric Grid Readiness:** Air District commissioned research has confirmed that the implementation of Rule 9-6 will not result in significant unplanned burden to the electrical grid. Additionally, the flexibility amendments account for scenarios in which access to additional building-level electrical capacity is limited.
- **Homeowner Costs:** The estimated \$3,500 incremental cost of installation is a one-time investment that may be partially offset through rebates. The exemption pathways are designed to avoid requiring replacement in situations that would result in high-cost installations. Additionally, associated health benefits will accrue continuously once the replacement is completed.

### **Communications and Outreach**

A multi-phase communications campaign is underway to support implementation of Rule 9-6. The campaign will focus on increasing understanding of the health impacts of NOx- emitting appliances, the benefits of zero NOx technologies and key steps for replacement.

Outreach will be conducted through multiple channels, including contractors, local governments, media, and community organizations, with messaging tailored to different audiences over time.

### **Staff Recommendations**

Staff are seeking Board consensus on the following recommendations to continue moving forward with the planned amendments:

1. **Low-Income Qualification Criteria:** Staff recommend defining eligible households as those either participating in an existing low-income program (e.g. Medicaid, food stamps, etc., with a household income  $\leq 250\%$  of federal poverty guidelines) or experiencing housing cost burden (i.e. housing costs  $\geq 28\%$  of gross income). This approach aims to capture a broader set of financially vulnerable households.
2. **Requirement for Contractors:** Staff recommend that project-specific exemptions be evaluated and verified by contractors. This ensures an accurate assessment of technical constraints and alignment with evolving technologies.
3. **One-Time Exemption per Address:** Staff recommend that only one exemption is allowed per property, providing approximately 13 years (one equipment lifecycle) for owners to prepare for eventual compliance. This balances near-term feasibility with long-term policy goals and ensures eventual realization of all emissions benefits.
4. **Delayed Implementation Date (October 2027):** Staff recommend postponing the rule's effective date one year to October 1, 2027 to allow additional time for online system development, market alignment, workforce training, and public outreach. While this delay supports smoother implementation, it also postpones the associated air quality benefits.

## Next Steps

Air District staff plan to release detailed proposed rule language, along with updated environmental and socioeconomic analyses, in advance of a targeted vote for adoption of the amendments by the Board of Directors in October 2026. Continued stakeholder engagement and refinement of the proposal will occur throughout this period.

## BUDGET CONSIDERATION/FINANCIAL IMPACT

None.

Respectfully submitted,

Philip M. Fine  
Executive Officer/APCO

Prepared by: Jennifer Lam  
Reviewed by: Gregory Nudd

ATTACHMENT(S):

1. Rule 9-6 Regulatory Overview May
2. Rule 9-6: Flexibility and Affordability Amendments for Zero NOx Water Heaters Presentation

# REGULATORY OVERVIEW: RULE 9-6 FLEXIBILITY AMENDMENTS

APRIL 2026  
Bay Area Air District

REGULATORY DEVELOPMENT DIVISION & PLANNING DIVISION

## PRIMARY AUTHORS

**Amy Dao**, Acting  
Advanced Projects  
Advisor – Planning

**Eric Lara**, Senior Air  
Quality Specialist –  
Regulatory  
Development

**Poornima Dixit**, PhD  
Senior Air Quality  
Engineer – Regulatory  
Development

## CONTRIBUTORS

**Sally Newman**, Senior  
Air Quality Specialist –  
Planning

**Richard Chien**,  
Manager – Planning

**Jennifer Lam**, Manager  
– Regulatory  
Development

## REVIEWED BY

**Gregory Nudd**, Deputy  
Executive Officer –  
Policy

**Philip Fine**, PhD, Air  
Pollution Control Officer

## Table of Contents

|  |    |
|--|----|
| Executive Summary.....   | 5  |
| Introduction: Rules 9-4 & 9-6 .....  | 7  |
| Clarifying Common Misconceptions.....  | 8  |
| Health Benefits from Implementing Rules 9-4 & 9-6 Amendments .....                     | 8  |
| Background .....   | 10 |
| Current Status and Compliance Timeline.....  | 10 |
| Implementation Working Group.....  | 13 |
| IWG Phase 1 Findings .....   | 13 |
| Overview of Draft Concepts for Potential Rule Amendments .....                         | 15 |
| Continued Sales of Smaller Units and Hydronic Systems.....                             | 15 |
| Certified Exemptions for Purchase and Installation of NOx-emitting Water Heaters ..... | 15 |
| Based on Project Constraint .....  | 15 |
| Based on Applicant Type .....  | 16 |
| Development of Web Portal for Processing Applications .....                            | 18 |
| Economic Considerations .....  | 19 |
| Challenging Installations .....  | 19 |
| Average Upfront and Operational Costs .....  | 19 |
| Socioeconomic Impact Evaluation .....  | 21 |
| Available Rebates .....  | 22 |
| Summary of Potential Impacts and Considerations.....                                   | 24 |
| Grid and Reliability Impacts .....   | 24 |
| Potential Renter Impacts.....  | 24 |
| Workforce Development and Availability.....  | 25 |
| Quantitative Estimates on Number of Exemptions.....                                    | 25 |
| Health Equity vs. Economic Equity Considerations.....                                  | 27 |
| Appendix A.....  | 30 |
| Appendix B .....   | 34 |
| References for Income Qualified Calculations .....                                     | 34 |

|  |           |
|--|-----------|
| Appendix C .....   | 35        |
| Sources for Project Constraint Estimates.....  | 35        |
| Appendix D .....   | 36        |
| Average Estimated Upfront and Incremental Costs.....                                     | 36        |
| <br>   |           |
| <b>Table 1. Simplified Myths Vs. Facts for the Currently Adopted Rule 9-6 .....</b>      | <b>8</b>  |
| <b>Table 2. Health Benefits from Rule 9-4 &amp; 9-6 .....</b>                            | <b>9</b>  |
| <b>Table 3. Current Compliance Schedule for Rules 9-4 and 9-6 .....</b>                  | <b>10</b> |
| <b>Table 4. Post-Adoption Timeline of Regulatory Events for Rules 9-4 &amp; 9-6.....</b> | <b>11</b> |
| <b>Table 5. Technical Research on Implementation Issues .....</b>                        | <b>14</b> |
| <b>Table 6. Available HPWH rebates in the Bay Area as of March 2026 .....</b>            | <b>22</b> |
| <b>Table 7. Residential Certified Exemptions Expected by Category .....</b>              | <b>26</b> |
| <b>Table 8. Equity Considerations .....</b>  | <b>27</b> |

## Executive Summary

In March 2023, the Bay Area Air District Board of Directors adopted amendments to Regulation 9, Rule 6 (“Rule 9-6”) that established a zero nitrogen oxides (NOx) standard for all sales and installations of covered water heaters beginning with those manufactured after January 1, 2027. These amendments did not include any flexibilities or exemptions for any potential extenuating circumstances. Over the past two years, Air District Staff have collaborated with stakeholders to develop and refine potential amendments to introduce flexibility into the zero NOx standard, with the intention of easing requirements and potential cost impacts and provide options for an easier transition.

The Air District convened an external Implementation Working Group (IWG) comprised of over 40 members representing a variety of stakeholder segments to identify and compile potential solutions to identify implementation barriers. The IWG’s focus areas included technology readiness, costs, permitting, workforce, grid capacity, and equitable access to incentives and financing. Over 20 IWG meetings were held between May 2023 and August 2024 that informed staff’s December 2024 Board update and subsequent October 2025 preliminary concepts paper for flexibility and affordability amendments.

The amendments discussed in this regulatory overview would provide flexibility in the following scenarios:

- Challenging installations due to space constraints, existing electrical system or panel upgrades. (see Appendix A for details)
- Low-income qualified property owners (see Appendix B for details)
- Water heaters with a capacity of less than 35 gallons<sup>1</sup>
- Hydronic water heating systems
- Businesses with high-heat demand (Examples: restaurants, healthcare, dry cleaners, etc.)
- Temporary emergency gas water heater installed by certified contractors

Staff estimate that the average incremental cost to install a heat pump water heater for a “standard” project is approximately \$3,500. Of this, the incremental retail cost of a heat pump water heater as compared to a new natural-gas fired unit ranges from \$600 - \$1,600. The remaining cost difference is due to additional labor to install the unit.

As seen in Figure 1 below, staff estimate up to 38 percent of new water heater installations would qualify for exemptions (Appendix E). Income-based eligibility exemptions for low-

---

<sup>1</sup> Staff is also considering setting this threshold at 30 gallons, based on feedback from manufacturers. Staff welcomes additional feedback on this issue.

income or housing cost burdened property owners would account for approximately 18 percent. Project or building constraints, such as space or electrical limitations, account for another 20 percent. Given the technical nature of the project specific exemptions, some participation from licensed contractors would be required.

**Figure 1. Breakdown of Estimated Distribution of Exemption Pathways**

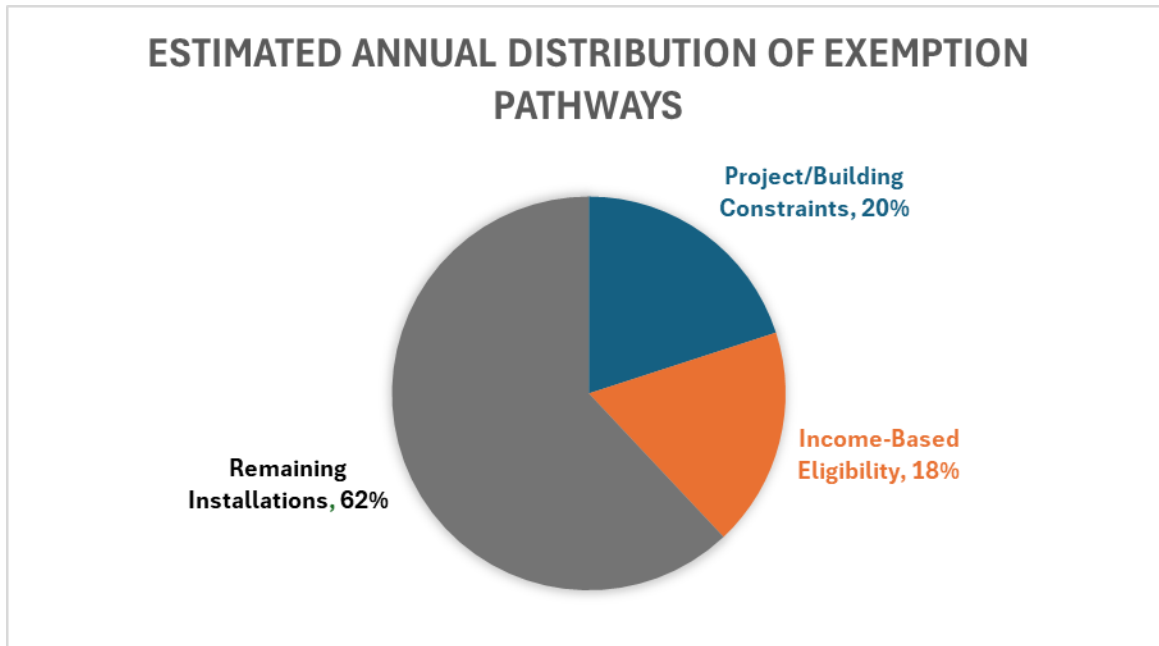

In order to provide sufficient time to make necessary upgrades while still ensuring that emission reductions are achieved over time, staff recommend that project-specific exemptions be granted on a *one-time basis* per address or location. For water heaters less than 35 gallons and hydronic units, staff recommend amending the compliance date to January 1, 2031 to allow for more time for market development and for the IWG to further evaluate technology readiness and costs at the appropriate time.

Staff plans to provide a website for property owners to request and immediately receive exemptions. The goal is to make that process as fast and seamless as possible while ensuring that rule requirements are met.

## Introduction: Rules 9-4 & 9-6

The Bay Area Air District has two adopted building appliance rules that address pollution from gas fueled equipment in buildings.<sup>2</sup>

- Regulation 9, Rule 4: Nitrogen Oxides from Fan Type Residential Central Furnaces, which regulates small residential and commercial furnaces that heat indoor air
- Regulation 9, Rule 6: Nitrogen Oxides from Natural Gas-Fired Boilers and Water Heaters regulates natural gas water heaters and small boilers that are used to heat water
- These rules **do not** apply to gas stoves, laundry drying, or any other appliance that may use natural gas.

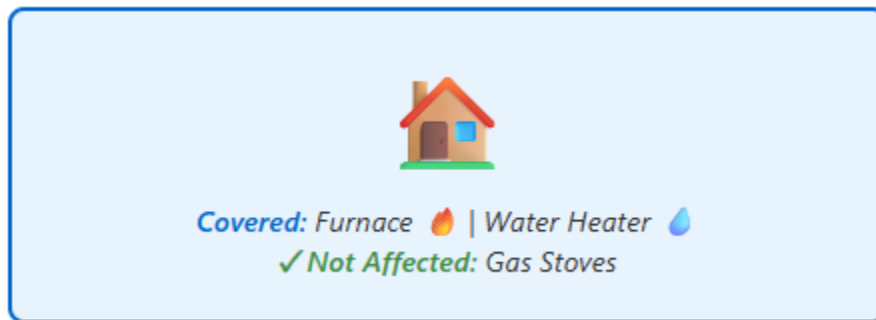

Rules 9-4 and 9-6 were first **adopted more than 30 years ago** to reduce nitrogen oxides (NOx) emissions from these everyday appliances, because NOx contributes to the formation smog and fine particles (i.e. particulate matter, or PM) that result in harmful health effects.

In March 2023, the Board adopted amendments to Rules 9-4 and 9-6 that tighten **“point-of-purchase”** emission standards for small furnaces and water heaters, including new zero NOx standards that start to phase in between 2027 and 2031 depending on the size and type of equipment. These updated standards apply to the new replacement appliances that would be installed when an existing appliance reaches the end of its life (“burn out”) and needs to be replaced, and to new equipment manufactured after the future compliance dates.

---

<sup>2</sup> <https://www.baaqmd.gov/en/rules-and-compliance/rule-development/building-appliances>

## Clarifying Common Misconceptions

The overarching goal of this rule amendment effort for Rule 9-6 is to support equity and affordability for residents while continuing to achieve the air quality benefits associated with the replacement of polluting equipment over time.

Staff have received several recurring questions regarding the applicability and implementation of Rule 9-6 during stakeholder engagement. In some cases, the interpretations stem from misunderstandings about when or how the rule applies. **Table 1** below highlights several common misconceptions and provides clarification of the actual requirements of the currently adopted Rules 9-4 and 9-6, prior to any potential changes discussed elsewhere in this document.

**Table 1. Simplified Myths Vs. Facts for the Currently Adopted Rule 9-6**





| Myths   | Facts  |
|---|--|
| <i>Mandatory replacements of all equipment starting in 2027</i>   | <b>Existing water heaters can remain in operation until they burn out or need replacement</b>  |
| <i>Point-of-purchase requirement</i>                              | <b>The rule is triggered when equipment is replaced (purchased), not when a property is sold</b>   |
| <i>Applicability based on building type or installation date</i>  | <b>Requirements are based on the appliances btu rating and date of manufacture</b>   |
| <i>This rule is an electrification or decarbonization mandate</i> | <b>The rule reduces regional NOx emissions caused by natural gas combustion and the associated PM<sub>2.5</sub> formation to improve air quality and public health</b> |
| <i>This rule applies to stoves, ovens and dryers</i>              | <b>The rule does not apply to stoves, ovens, nor dryers.</b>   |

## Health Benefits from Implementing Rules 9-4 & 9-6 Amendments

By phasing out polluting gas furnaces and water heaters starting in 2027, Rules 9-4 and 9-6 will help clean up the air we all breathe, prevent dozens of early deaths every year, and save

the region hundreds of millions of dollars in health costs. A summary of the health benefits is shown in the table below.<sup>3</sup>

**Table 2. Health Benefits from Rule 9-4 & 9-6**

| Major health benefits from Rules 9-4 and 9-6   |   |
|--|---|
| These appliance rules help improve regional air quality by reducing pollution from furnaces and water heaters. |  <p><b>Cleaner outdoor air</b><br/>Less NOx &amp; PM<sub>2.5</sub> from venting</p>  |
| Lower pollution means lower exposure to fine particles (PM <sub>2.5</sub> )                                    |  <p><b>Cleaner Bay Area Communities</b><br/>Biggest PM<sub>2.5</sub> reductions in communities of color &amp; overburdened neighborhoods</p> |
| Reducing PM <sub>2.5</sub> and NOx exposure can prevent dozens of early deaths every year in the Bay Area.     |  <p><b>Up to 85 early deaths avoided</b> each year from cleaner air</p>  |
| Health improvements from cleaner air avert unnecessary costs from health impacts.                              |  <p><b>Up to \$890M</b><br/>Annual health benefits saved in avoided illnesses, hospital visits, and early deaths<sup>4</sup></p>           |
| Climate co-benefits resulting from electrification of appliances   | Based on current technology, zero NOx appliances are electric, and their use would result in a <b>reduction of greenhouse gas emissions</b>   |

<sup>3</sup> [https://www.baaqmd.gov/~/media/dotgov/files/rules/reg-9-rule-4-nitrogen-oxides-from-fan-type-residential-central-furnaces/2021-amendments/documents/20230307\\_fsr\\_rules0904and0906-pdf.pdf?rev=100de6caff2342e6b095b59acf2321d0](https://www.baaqmd.gov/~/media/dotgov/files/rules/reg-9-rule-4-nitrogen-oxides-from-fan-type-residential-central-furnaces/2021-amendments/documents/20230307_fsr_rules0904and0906-pdf.pdf?rev=100de6caff2342e6b095b59acf2321d0)

<sup>4</sup> [https://www.baaqmd.gov/~/media/dotgov/files/rules/reg-9-rule-4-nitrogen-oxides-from-fan-type-residential-central-furnaces/2021-amendments/documents/20221220\\_sr\\_apppe\\_rg09040906-pdf.pdf?rev=d4b056153496491fad817c6d4a87df78&sc\\_lang=en](https://www.baaqmd.gov/~/media/dotgov/files/rules/reg-9-rule-4-nitrogen-oxides-from-fan-type-residential-central-furnaces/2021-amendments/documents/20221220_sr_apppe_rg09040906-pdf.pdf?rev=d4b056153496491fad817c6d4a87df78&sc_lang=en)

# Background

## Current Status and Compliance Timeline

For the past 30 years, the Air District has been updating these rules to reflect newer, cleaner technologies and to help meet the region’s clean air goals. In March 2023, the Board adopted amendments to Rules 9-4 and 9-6 that tighten “**point-of-purchase**” emission standards for small furnaces and water heaters, including new zero NOx standards that start to phase in between 2027 and 2031 depending on the size and type of equipment. These updated standards apply to the new replacement appliances that would be installed when an existing appliance reaches the end of its life (“burn out”) and needs to be replaced, and to new equipment manufactured after the future compliance dates. The current compliance schedule for zero NOx equipment is shown below.

**Table 3. Current Compliance Schedule for Rules 9-4 and 9-6**

|                        |  |
|------------------------|--|
| <b>January 1, 2027</b> | Water heaters less than 75,001 BTU/hr <sup>5</sup> (typically residential tank water heaters)                      |
| <b>January 1, 2029</b> | Residential and commercial furnaces  |
| <b>January 1, 2031</b> | Water heaters between 75,001 and 2 million BTU/hr (typically commercial and multifamily as well as tankless units) |

*(The above only applies to appliances manufactured after the noted date)*

Together, Rules 9-4 and 9-6 are a key part of the Air District’s broader strategy to reduce air pollution from stationary sources, including buildings. The staff’s technical analysis for these rules clearly show that emissions from gas furnaces and water heaters affect both local and regional air quality, contribute to ozone and secondary particulate matter formation, and exacerbate health and equity concerns in the Bay Area.

The 2023 amendments to Rules 9-4 and 9-6 included a provision to report back to the Board of Directors two years prior to each implementation date on the current state of available technologies, costs and other potential implementation challenges. The Board of Directors directed staff to include a provision in the 2023 amendments to establish an Implementation Working Group, consisting of a wide spectrum of stakeholders, and called for the corresponding report to inform any further changes to the rules.

---

<sup>5</sup> BTU/hr means British thermal unit per hour

**Table 4** below summarizes the Board’s actions over time, showing what has happened so far and where the rule currently stands. This timeline provides context for how Rule 9-6 has progressed from adoption to subsequent discussions regarding updates and flexibility.

**Table 4. Post-Adoption Timeline of Regulatory Events for Rules 9-4 & 9-6**

| Date                    | What happened?  | Brief description   |
|-------------------------|---|---|
| <b>March 15, 2023</b>   | The Board of Directors adopted amendments to 9-4 & 9-6. The Board also directed staff to come back with a Rule 9-6 implementation report in 2024. | The Board held a public hearing and adopted the proposed amendments to Rules 9-4 and 9-6, and certified the CEQA Environmental Impact Report, formally approving the new zero NOx standards and related requirements.   |
| <b>June 21, 2023</b>    | The Board heard details on SIP submittal of Rules 9-4 & 9-6   | The Board of Directors held a public hearing and directed staff to submit the current versions of Rules 9-4 and 9-6 to U.S. EPA and the California Air Resources Board for inclusion in the State Implementation Plan (SIP). That process is currently on hold while the Air District develops its attainment plan for the new PM <sub>2.5</sub> air quality standard.  |
| <b>December 4, 2024</b> | The Board received information on staff’s research on Rule 9-6 implementation per the 2023 direction.   | Staff presented informational updates on implementation readiness of the zero NOx requirements for residential water heaters under Rule 9-6, summarizing the Implementation Working Group findings and professional research in a <a href="https://www.baaqmd.gov/~media/dotgov/files/rules/reg-9-rule-4-nitrogen-oxides-from-fan-type-residential-central-furnaces/2021-amendments/documents/20241127_board-report-dec-2024-pdf.pdf?rev=f9b89cc7ceb54588b5c505d6f20635e3&amp;sc_lang=en">Rule 9-6 Implementation Report</a> . <sup>6</sup> |

<sup>6</sup> [https://www.baaqmd.gov/~media/dotgov/files/rules/reg-9-rule-4-nitrogen-oxides-from-fan-type-residential-central-furnaces/2021-amendments/documents/20241127\\_board-report-dec-2024-pdf.pdf?rev=f9b89cc7ceb54588b5c505d6f20635e3&sc\\_lang=en](https://www.baaqmd.gov/~media/dotgov/files/rules/reg-9-rule-4-nitrogen-oxides-from-fan-type-residential-central-furnaces/2021-amendments/documents/20241127_board-report-dec-2024-pdf.pdf?rev=f9b89cc7ceb54588b5c505d6f20635e3&sc_lang=en)

| Date                     | What happened?   | Brief description  |
|--------------------------|--|--|
| <b>October 2025</b>      | Public Release of Rule 9-6 Concepts Paper (flexibility options)  | Staff released the <b>Rule 9-6 Concepts Paper</b> , outlining potential flexibility concepts for amending Rule 9-6. The flexibility amendments are a result of findings from the 2024 implementation report that recognized constraints for seamless adoption of Rule 9-6. <sup>7</sup>  |
| <b>December 10, 2025</b> | The Stationary Source Committee received information from staff on potential flexibility amendments based on affordability and availability issues for Rule 9-6. | Staff presented informational updates on flexibility amendments to Rule 9-6 which would address issues that would make the rule more practical to implement. Staff’s discussion highlighted the concept paper and the public comments received on the concept paper.<br><br><b><i>The Committee directed staff to come back with information on possible exemptions for low-income property owners.</i></b>  |
| <b>February 11, 2026</b> | Per direction from the 12/10/2025 Stationary Source Committee meeting, staff presented specifics on options for defining and qualifying low-income affordability | Staff presented to the Stationary Source Committee on:<br><br><ol style="list-style-type: none"> <li>1. Who qualifies as "low-income" – presenting two options including different income limits as well as considerations for housing cost burden</li> <li>2. How much does it cost to help low-income households switch to cleaner water heaters</li> </ol> <b><i>The Committee directed staff to return in May 2026 with a full set of final options so the full Board can give clear directions on how to proceed with the rule.</i></b> |

<sup>7</sup> [https://www.baaqmd.gov/~/media/dotgov/files/rules/reg-9-rule-4-nitrogen-oxides-from-fan-type-residential-central-furnaces/2021-amendments/documents/rule-09\\_06-concepts-paper\\_final-v1-pdf.pdf?rev=9eac6fc7a84e4b259fd2017c838de68c&sc\\_lang=en](https://www.baaqmd.gov/~/media/dotgov/files/rules/reg-9-rule-4-nitrogen-oxides-from-fan-type-residential-central-furnaces/2021-amendments/documents/rule-09_06-concepts-paper_final-v1-pdf.pdf?rev=9eac6fc7a84e4b259fd2017c838de68c&sc_lang=en)

## Implementation Working Group

As part of the 2023 zero NOx amendments, the Board required that two years prior to each compliance date, staff must provide updates to the Board regarding implementation challenges, especially focused on concerns raised by stakeholders during rulemaking—such as costs, workforce, market development, and equity issues in terms of incentives and tenant impacts. With this direction, staff coordinated and led a multi-stakeholder Implementation Working Group (IWG) focusing primarily on the Rule 9-6 amendments (IWG Phase 1), holding **21 meetings** from May 2023 through August 2024<sup>8</sup> to provide input on those topics relevant to January 2027 implementation for small water heaters less than 75,000 BTU/hr. Members included industry representatives, union representatives, industry associations, local governments, utilities, community choice aggregators and subject matter expert organizations, among others.

The IWG was comprised of various subcommittees. The Technical Subcommittee compiled and reviewed the most up-to-date technical information relevant to implementing Rule 9-6 to present to the Working Group, such as market availability and projected cost of compliant appliances, and potential financial incentives for consumers. The Technical Subcommittee also provides recommendations for the Working Group and/or Steering Committee to consider.

## IWG Phase 1 Findings

Overall, staff found that even in just a short two-year timeframe (2023-2024), several significant challenges brought up during the 2022 rulemaking process had been mitigated or were found not to be major barriers to Rule 9-6 implementation (e.g., water heater impacts to the grid and reliability, market readiness including post-Covid supply chain, workforce availability, and local jurisdictional permit streamlining). However, some challenges remain, and staff’s overall recommendation highlighted the need for future flexibility and amending the 100 percent sales requirement. To review all findings, please see the [IWG Phase 1 Staff Report Informational Update Regarding Regulation 9, Rule 6](#),<sup>9</sup> which was presented to the Board of Directors in December 2024.

The following table provides a brief overview of the milestone deliverables prepared for the Building Appliances Implementation Working Group. Each technical report addresses a

---

<sup>8</sup> <https://www.baaqmd.gov/community-health/building-appliances-rule-implementation/building-appliances-implementation-working-group>

<sup>9</sup> [https://www.baaqmd.gov/~/\\_media/dotgov/files/rules/reg-9-rule-4-nitrogen-oxides-from-fan-type-residential-central-furnaces/2021-amendments/documents/20241127\\_board-report-dec-2024-pdf.pdf?rev=f9b89cc7ceb54588b5c505d6f20635e3](https://www.baaqmd.gov/~/_media/dotgov/files/rules/reg-9-rule-4-nitrogen-oxides-from-fan-type-residential-central-furnaces/2021-amendments/documents/20241127_board-report-dec-2024-pdf.pdf?rev=f9b89cc7ceb54588b5c505d6f20635e3)

distinct implementation issue and helped inform the Air District’s analysis of Rule 9-6 implementation.

**Table 5. Technical Research on Implementation Issues**

| Technical Report   | Brief Description  |
|--|--|
| <a href="#">Installation Costs for Zero NOx Space and Water Heating Appliances</a>   | Updates the estimated installation costs of zero NOx heating appliances and how incentives affect household bills and upfront costs. |
| <a href="#">Workforce Challenges for Zero NOx Requirements</a>                       | Reviews contractor availability, training needs, and workforce readiness for heat pump adoption.                                     |
| <a href="#">Challenging Use Cases and Emerging Solutions for Zero NOx Appliances</a> | Identifies difficult retrofit situations and summarizes practical solutions for constrained sites.                                   |
| <a href="#">Renter Protections Policy Landscape Summary</a>                          | Reviews renter-protection policies and suggests ways to reduce possible negative impacts on tenants.                                 |
| <a href="#">Market and Sales Trends for Zero NOx Appliances</a>                      | Summarizes market conditions, sales trends, and contractor input on the current and future heat pump market.                         |
| <a href="#">Permitting Requirements for Zero NOx Appliances</a>                      | Describes permitting barriers, requirements, and best practices for installing zero NOx appliances.                                  |
| <a href="#">Grid Reliability and Interconnection Challenges</a>                      | Examines concerns about electric grid reliability, service upgrades, outages, and appliance-level performance.                       |
| <a href="#">Lived Experience Interviews Summary</a>                                  | Summarizes renter interviews on housing insecurity, displacement, energy burden, and other quality-of-life impacts.                  |

# Overview of Draft Concepts for Potential Rule Amendments

In October 2025, staff released a [Concepts Paper](#) outlining potential future amendments to Rule 9-6 directly addressing the challenges identified in the implementation working group report and described above. Below is a full summary of each concept.

## Continued Sales of Smaller Units and Hydronic Systems

- 1) **35-gallon and less tanked size.** There are currently no 35-gallon or smaller HPWHs available in the US market. Based on this market gap, NOx-emitting 35- gallon and smaller tanked water heaters could continue to be allowed for sale and installation. Retailers, distributors, purchasers and installers could be allowed to sell, purchase and install water heaters in this category until an extended compliance date of January 1, 2031. Based on feedback from manufacturers, staff is also considering proposing this threshold be set at 30 gallons, rather than 35.
- 2) **Hydronic Systems.** A hydronic water heater is a system that heats water and circulates it through pipes or through an air handler to provide space heating. Standard HPWHs are generally not a suitable direct replacement for a dedicated hydronic heating system. HPWHs lack the additional heat rating provided by natural gas fired units to operate as part of a recirculating, closed-loop hydronic system. Though there are currently a limited number of hydronic heat pump water heaters on the market, the product carries a significant price premium. Hydronic systems are typically installed in multi-unit apartment complexes that require substantial pre-planning and coordination to complete the installations. In order to ensure as minimal renter impacts as possible, and to allow for new technology to develop in this category, staff recommend delaying to a 2031 compliance date. For units manufactured after January 1, 2031, sales of NOx-emitting water heaters in this category could be subject to the same requirements as other larger units.

## Certified Exemptions for Purchase and Installation of NOx-emitting Water Heaters

### Based on Project Constraint

Certified exemptions based on project constraints would be allowed through application, documentation and attestation with a licensed contractor. Though this requirement may lengthen the process for property owners, especially those who would have utilized an unlicensed handyman or conducted “DIY” self-installation, licensed contractors are more

likely to have the knowledge needed to accurately evaluate multiple technical options for installing a zero NOx water heater and will be more capable of staying up-to-date on technology options as they evolve.

- 1) **Space Constraints.** Water heater relocation and major construction due to existing space constraints within the home is a major cause of higher installation costs. Flexibility for these scenarios would allow licensed contractors to apply for a space constraint exemption, based upon either lack of access to sufficient space for ventilation, or lack of physical space as listed below.

|   |
|---|
| <b>Ventilation:</b> The location of the existing /old water heater has less than 700 cubic feet of space AND is not adjacent to a space >700 c.f. and therefore cannot be retrofitted with a louvered door, transfer grille or air ducts. |
|---|

|  |
|--|
| <b>Physical space:</b> The existing/old water heater is in a garage with a ceiling height less than 7.2' tall OR a non-garage space with ceiling height less than 6' tall. <sup>10</sup> |
|--|

- 2) **Electrical Constraints.** In homes and buildings with outdated or limited electrical infrastructure, staff have identified several constraints that may justify an exemption, as listed below.

|   |
|---|
| The home/building has knob-and-tube wiring. |
|---|

|  |
|--|
| The electrical panel is <100 amps (single-family) or <60 amps (multi-family) |
|--|

|  |
|--|
| New 240v connection requires more than 50 feet of wiring/conduit |
|--|

|  |
|--|
| The electrical panel does not have enough circuit or breaker space |
|--|

The objective would be to exempt homes that will likely need to upsize their electric panel and/or install significant new wiring. The exemptions would also preclude the need for costly and time-consuming PG&E service upgrades, since PG&E cannot bring upsized service to an undersized panel (e.g. 200-amp service to a 90-amp panel).

## Based on Applicant Type

- 1) **Low-Income Qualified Property Owners.** Given the incremental cost of HPWHs as well as lack of guaranteed, long-term sufficient funding for incentives serving low-income households, staff recommend an exemption category for low-income qualified property owners.

---

<sup>10</sup> See “Low Clearance Garages” and “Low Clearance Spaces”. [https://svcleanenergy.org/wp-content/uploads/electrification\\_solutions\\_analysis\\_svce\\_webpage\\_jan2026\\_noc.pdf](https://svcleanenergy.org/wp-content/uploads/electrification_solutions_analysis_svce_webpage_jan2026_noc.pdf)

Staff Recommendation: property owners that are either low-income program participants<sup>11</sup> (e.g., food stamps, Family Electric Rate Assistance (FERA) or California Alternative Rates for Energy (CARE) programs) OR housing cost burdened (annual mortgage and property taxes are equal to or greater than 28 percent of gross income). By including housing cost burden, this approach acknowledges the issues of affordability, high housing costs in the region and how that impacts households across different income levels.

There are alternatives to determining low-income status. For example: property owners at or below 80 percent Area Median Income (AMI). Given the complexity of using AMI as it relates to public communication and customer experience (e.g., income thresholds vary by county and change annually; varies based on the number of people in the household; definition of “household” varies amongst public programs), staff recommends the housing cost burden or low-income program approach.

- 2) **Licensed Contractors: Emergency Replacement Loaners.** Approximately 75 percent of TECH Clean CA HPWH single-family projects statewide took just one day for installation. For Bay Area HPWH single-family projects installed within two days, the number rises to 82 percent. With greater availability of 120-volt plug-in HPWHs, including a new “dual voltage” convertible HPWH that can operate at either 120- or 240-volts,<sup>12</sup> a growing number of emergency replacements can be completed with zero NOx options just as quickly as NOx emitting units.

However, for some emergency replacement scenarios, including retrofits with longer timelines, a temporary gas-fired NOx-emitting water heater may be needed. To meet this limited demand, licensed contractors would be allowed to apply for and purchase a certain number of NOx-emitting water heaters to utilize as temporary loaners. These loaners would not need to be purchased based on a specific project, but could be pre-purchased by licensed installers in order to have on-hand. This would help avoid the need for exemptions if cost was less of a factor than time delays for the property owner.

- 3) **Businesses with specialized applications and high hot water demand.** Small business types with operational requirements for high hot water needs and/or

---

<sup>11</sup> Typically using 250% Federal Poverty Guidelines

<sup>12</sup> <https://www.geappliances.com/geospring-water-heater>

health and safety codes to provide hot water at specified temperatures could be eligible to apply for self-certification exemption. The list below provides some examples of business types that could be covered by this exemption.

|                                |
|--------------------------------|
| Restaurant, Food Service       |
| Laundry, Dry Cleaner           |
| Healthcare and assisted living |

The self-certification process could be designed to ensure that businesses are made aware of their zero NOx options and benefits, and any incentive programs available to them.

## Development of Web Portal for Processing Applications

Staff plan to develop a centralized web portal location on the Air District’s home webpage for anyone seeking a certified exemption for any of the exemption options listed above. The portal would be customer friendly and would require documentation and attestation prior to purchase and installation.

When applying for an exemption, staff intend to provide educational resources embedded into the web portal to notify property owners and contractors of incentives that may be available to them based on their location and income level. It is staff’s intention to provide residents information to make an informed decision about whether they would like to continue to pursue an exemption to Rule 9-6 or to purchase and install a zero NOx appliance with the help of incentives or other financing.

The certification process as part of the registration portal could be designed to require that contractors must make property owners aware of their zero NOx options, right-sizing (120-volt plug-in HPWHs; circuit-sharing; skinny breakers, etc.), benefits, as well as the incentive programs available to them.

# Economic Considerations

## Challenging Installations

Variations across the building stock (i.e. existing space configuration, existing electrical system and panel condition, amount of deferred maintenance) will result in some challenging installation cases for zero NOx water heating. TECH Clean CA<sup>13</sup> program data for heat pump water heater (HPWH) installations in the Bay Area showed costs ranging from \$2,900 to \$38,800, with the high end of costs representing the most challenging installation cases. It should be noted that this data on costs only includes completed jobs and includes data from years before new and improved products were available on the market. These high-cost edge cases are typically driven by either electrical or space constraints. Specifics around drivers for electrical and space constraints, potential heat pump configurations and available data on projects that face these constraints can be found in Appendix A.

## Average Upfront and Operational Costs

For the remaining projects that may not be eligible for one of the potential exemptions, or more “standard” projects or “drop-in” replacements, staff estimate average incremental cost to remain at approximately \$3,500. Original IWG research was based on a large dataset of over 4,000 incentive program projects with very little difference between mean versus median costs. These amendments would help to eliminate the high-cost projects or other outliers. Therefore, staff expect average costs to be similar to the IWG estimates.

Retail additional (incremental) cost for the equipment only is as follows for most basic models with 50 gallon tanks:

- **120V:** \$1,100-\$1,600
- **240V:** \$600-\$1,300<sup>14</sup>

---

<sup>13</sup> TECH Clean California is a statewide initiative to accelerate the adoption of heat pumps across California homes, overseen by the CA Public Utilities Commission and the CA Energy Commission.

<https://techcleanca.com/>

<sup>14</sup> Baseline assumes midpoint of \$900 MSRP for ultra low NOx natural gas tanked water heaters: Low end: \$770 (e.g. Rheem Performance 50 gal. Tall 6-Year 34,000 BTU Ultra Low NOx Natural Gas Tank Water Heater; A.O. Smith Signature 100 50-Gallon Tall 6-year Warranty 50000-BTU Natural Gas Water Heater) ; Higher end: \$1100 (e.g. Rheem Performance Platinum 50 Gal. Tall 38,000 BTU Ultra Low NOx Natural Gas Water Heater)  
Zero NOx water heater costs: 120V: \$2,000 - \$2,500 (e.g., GE GeoSpring 120V, Rheem 120V); 220V: \$1,500 - \$2,200 (e.g. A.O. Smith Signature 900, Rheem ProTerra, A.O. Smith HPTS-50 Voltex)  
Online retailer websites accessed February and March 2026.

Note that most of the upfront costs for HPWH projects consist of labor and installation, along with permitting costs. HPWHs can require extra labor compared to a like-for-like gas water heater due to:

- new electrical wiring
- condensate management or new drain lines
- potential ventilation measures for water heaters in confined spaces (ducts, louvered doors)
- capping the old water heater gas line; and
- further components such as mixing valves, heat exchangers, and vibration-reducing flexible piping.

These are mostly one-time upgrades that will also support future water heater replacements. The number of higher cost installations that need these upgrades will be significantly reduced through the potential exemptions.

Staff expect that over time, larger pools of contractors and greater experience region-wide will lead to lower labor costs.

Operational costs analyses found that with the switch to HPWHs, households will either see utility bill savings or a very small monthly increase. 95 percent of high-usage customers (5,000 kWh or more annual usage before electrifying) see bill savings or no change in bills after switching to a HPWH. For low-use customers, approximately 35 percent of single-family and 60 percent of multi-family (MF) market-rate customers (those not receiving any low-income program discounts) experience a bill increase of around \$2 per month on average.

To understand upfront costs, the Air District analyzed incentive program data from multiple agencies (statewide, regional and local) covering over 4,000 projects installed exclusively in the Bay Area between 2021-2023. The average upfront additional incremental cost to install a zero NOx HPWH compared to a NOx-emitting gas water heater is estimated to fall between \$1,840, and \$3,496,<sup>15</sup> before rebates<sup>Error! Bookmark not defined.</sup>. This number varies based on the program analyzed and the types of projects and baseline appliance (tanked and tankless vs. tanked only) being replaced.

As noted in the IWG report, actual costs may vary depending on site conditions, equipment size, electrical upgrades, installation complexity, and energy prices. Although upfront costs for certain HPWH configurations can be higher than their gas counterparts, these costs can

---

<sup>15</sup> Installation Costs for Zero NOx Space and Water Heater Appliances  
[https://www.baaqmd.gov/~media/files/community-health/building-appliance-implementation/task1\\_electrificationcosts-pdf.pdf?rev=3cb66a09f3094f94b35fa7fc90cfd4ec](https://www.baaqmd.gov/~media/files/community-health/building-appliance-implementation/task1_electrificationcosts-pdf.pdf?rev=3cb66a09f3094f94b35fa7fc90cfd4ec)

often be offset through various available rebates or incentives, while comparable gas options may not. Zero NOx water heaters are expected to have lower operational energy costs for most customers.<sup>16</sup>

## Socioeconomic Impact Evaluation

The California Health and Safety Code requires that whenever an air district intends to propose the adoption, amendment, or repeal of a rule or regulation that will significantly affect air quality or emissions limitations, that agency must actively consider the socioeconomic impact of regulations and make a good faith effort to minimize adverse socioeconomic impacts. A “socioeconomic impact” means the following:

- a. The type of industries or business, including small business, affected by the rule or regulation.
- b. The impact of the rule or regulation on employment and the economy of the region affected by the adoption of the rule or regulation.
- c. The range of probable costs, including costs to industry or business, including small business, of the rule or regulation.
- d. The availability and cost-effectiveness of alternatives to the rule or regulation being proposed or amended.
- e. The emission reduction potential of the rule or regulation.
- f. The necessity of adopting, amending, or repealing the rule or regulation to attain state and federal ambient air standards.

For the 2023 Appliance Rule Amendments for Rules 9-4 and 9-6 for Nitrogen Oxide Emissions from Natural Gas-Fired Water Heaters, Boilers and Furnaces, staff additionally analyzed:<sup>17</sup>

- a. The direct impacts of increased compliance costs on residential consumers installing and replacing space and water heaters
- b. Potential equity impacts at the household level by different income groups, housing tenure, and poverty level.
- c. Monetized health impacts and benefits analysis of residents across the region based on race, including a range of valuations, based on modeled particulate matter exposures across the region and an equity assessment by race.
- d. Potential shifts in consumer spending and potential job losses (both direct and indirect/induced)
- e. Impacts to electrical grid capacity and reliability and related potential costs of related electric utility infrastructure upgrades

---

<sup>16</sup> *ibid* 15

<sup>17</sup> [https://www.baaqmd.gov/~/media/dotgov/files/rules/reg-9-rule-4-nitrogen-oxides-from-fan-type-residential-central-furnaces/2021-amendments/documents/20221220\\_sr\\_appc\\_rg09040906-pdf.pdf?rev=0680bc8794e74d53909fc180e4936de0&sc\\_lang=en](https://www.baaqmd.gov/~/media/dotgov/files/rules/reg-9-rule-4-nitrogen-oxides-from-fan-type-residential-central-furnaces/2021-amendments/documents/20221220_sr_appc_rg09040906-pdf.pdf?rev=0680bc8794e74d53909fc180e4936de0&sc_lang=en)

f. Air District costs to implement the proposals

The flexibility amendments being discussed at this time are expected to decrease costs as compared to the analysis conducted for the 2023 amendments and therefore does not necessitate conducting a socio-economic analysis under the California Health and Safety Code. Nevertheless, staff intend to publish an updated analysis outlining expected costs and other relevant items described above for consideration by the Board of Directors and the public.

### Available Rebates

A variety of rebates currently exist across federal, state, utility, and local programs, though availability can vary depending on funding cycles and program capacity. The low-income exemptions will help those property owners who are unable to afford the switch to compliant equipment, even with available funding.

Updated information on HPWH rebates available by zip code can also be found at [incentives.switchison.org](https://incentives.switchison.org). This information will be also be provided to property owners when they apply for the low-income exemption.

An updated snapshot of currently available rebates is included in **Table 6** below.

**Table 6. Available HPWH rebates in the Bay Area as of March 2026<sup>18</sup>**

| <b>Geographic Scope</b> | <b>Program or Funder Name</b>    | <b>Incentive amount per HPWH</b>                         |
|-------------------------|----------------------------------|--|
| Statewide               | Multifamily HEEHRA <sup>19</sup> | \$1,750  |
| City of Alameda         | Alameda Municipal Power (AMP)    | \$1,500  |
| Palo Alto               | City of Palo Alto Utilities      | \$3,500  |
| PCE customers           | Peninsula Clean Energy (PCE)     | up to \$3,000  |
| PG&E customers          | California Energy Smart Homes    | \$1,000 for Integrated Heat Pump Space and Water Heating |
| PG&E customers          | Golden State Rebates             | \$400-\$700  |
| Pinole                  | City of Pinole                   | up to \$3,000  |
| Redwood City            | Redwood City                     | Up to \$500  |

<sup>18</sup> <https://incentives.switchison.org/residents/incentives?state=CA> and filter for equipment “Heat Pump Water Heater”

<sup>19</sup> [High-Efficiency Electric Home Rebate Act \(HEEHRA\)](#), now often called [Home Electrification and Appliance Rebates \(HEAR\)](#)

|                |  |  |
|----------------|--|--|
| San Francisco  | Clean PowerSF Water Heater Upgrade Program | \$1,200 - \$1,800 in bill credits (\$50/month) |
| SCP customers  | Sonoma Clean Power (SCP)                   | \$700  |
| SJCE customers | San Jose Clean Energy (SJCE)               | \$2,000 to \$3,000                             |
| SVCE customers | Silicon Valley Clean Energy (SVCE)         | up to \$2,000                                  |

Note that **Table 6** does not include highly targeted funding programs available to limited households, including PG&E’s Energy Savings Assistance (ESA) program;<sup>20</sup> the California Energy Commission’s Equitable Building Decarbonization (EBD) Program;<sup>21</sup> and upcoming SB 1221 Neighborhood Decarbonization pilots.<sup>22</sup>

---

<sup>20</sup> <https://www.pge.com/en/save-energy-and-money/energy-saving-programs/energy-savings-assistance-program.html>

<sup>21</sup> <https://www.energy.ca.gov/programs-and-topics/programs/equitable-building-decarbonization-program>

<sup>22</sup> <https://www.cpuc.ca.gov/industries-and-topics/natural-gas/sb-1221-implementation>

# Summary of Potential Impacts and Considerations

## Grid and Reliability Impacts

Though often cited by the public as a concern, new electrical loads resulting from Rule 9-6 are highly unlikely to cause power outages. The change in electrical load due to the implementation of these rules will be spread over at least 15 years and is included in the State's ongoing planning for future enhancements of the electric grid. There are current and new (SB 410) requirements for utilities and the California Energy Commission (CEC) regarding grid planning for increasing loads, which will include added load from the building appliance rules.

The large majority of power outages are not caused by electrical load or bulk capacity issues but are instead caused by external physical impacts (e.g. downed trees, storms) or public safety power shutoffs (PSPS), which have been significantly reduced since 2019.<sup>23</sup>

For the rare instances of bulk capacity issues (e.g., statewide Flex Alerts), many HPWHs allow users to shift energy usage to off-peak hours (sometimes with the direct support from utilities), essentially using electricity to make and “store” hot water during periods of lower electricity demand and prices. HPWHs are increasingly being used by utilities for demand response to help improve overall grid reliability.

In the event of a power outage, tanked water heaters, including HPWHs, can stay hot for several hours, especially when installed with a cold-water mixing valve. Note that, some new NOx- emitting gas water heaters have dampers and fans (including tankless on-demand, tanked models with power venting) that rely on electricity and cannot operate during power outages.<sup>24</sup>

## Potential Renter Impacts

The Air District commissioned research and engaged stakeholders regarding concerns for renter impacts due to Rule 9-6. These analyses confirmed that implementation of the 2023 amended rule language could lead to capital cost pass-throughs, potential rent increases, and temporary evictions for some tenants, though water heaters covered under the 2027

---

<sup>23</sup> Rincon and E3. *Grid Reliability and Interconnection Challenges*.

[https://www.baaqmd.gov/~media/files/community-health/building-appliance-implementation/grid-impacts-final-pdf.pdf?rev=14a3ea4d46704d19a48cf03e3984c90e&sc\\_lang=en](https://www.baaqmd.gov/~media/files/community-health/building-appliance-implementation/grid-impacts-final-pdf.pdf?rev=14a3ea4d46704d19a48cf03e3984c90e&sc_lang=en)

<sup>24</sup>[https://docs.bradfordwhite.com/Spec\\_Sheets/1118\\_0815.pdf](https://docs.bradfordwhite.com/Spec_Sheets/1118_0815.pdf)

<https://www.hotwater.com/info-center/water-heater-venting.html#:~:text=Power%20Vent,professional%20plumbing%20contractor%20for%20installation>

requirements of Rule 9-6 posed a lower risk than other appliances due to lower costs and construction impacts.

Landlords could use a “substantial repair” clause found in the local and state renter protection laws for “no-fault evictions,”<sup>25</sup> creating potential eviction risk for some high-cost water heater installations. In these cases, “substantial repair” refers to significant construction work that requires the renter to vacate while the work occurs, takes more than 30 days, and requires a permit to complete.

Cities with the highest concentration of renters also have the strongest renter protections. San Jose, San Francisco, Oakland and an additional 13 Bay Area jurisdictions have local renter protection laws that go beyond state law. Each major jurisdiction has its own limits on rent increases and capital improvement pass-through costs, as well as eviction protections. In cities without local rent stabilization, renters rely on state protections. AB 1482 provides statewide rent increase limits and just cause eviction protections but does not specifically address capital improvement pass-throughs. The law expires in 2030.

## Workforce Development and Availability

Bay Area workforce research shows positive signs for contractor availability and readiness. Compared to national benchmarking, the Bay Area has equivalent levels of relevant contractors compared to the US average. Based on region-wide surveys, the majority of contractors are available to respond to emergency water heater failures within a couple days. A two-thirds majority of surveyed contractors were already aware of the building appliance rules and at least one category of applicable incentives, though slightly less than half of the surveyed contractors participated in incentive programs.

Further education for many installers is needed, however. Large-scale public awareness campaigns and specific outreach to installers are planned for 2026.

## Quantitative Estimates on Number of Exemptions

Total estimates for potential certified exemptions are estimated to be up to 38 percent of residential small water heater unit installs. This varies slightly depending upon how the low-income qualified exemption is defined. See **Table 7** below for a more detailed break out.

---

<sup>25</sup> No-fault evictions allow landlords to remove tenants who have not violated lease terms, but can occur under strict reasons, such as owner move-in, substantial remodeling, or removing units from the market.

**Table 7. Residential Certified Exemptions Expected by Category**

| Annual Residential Small Gas Water Heater Turnover: |                     | 120,000       |
|---|---------------------|---------------|
| Exemption type                                      | Percentage          | Annual Number |
| Very Low Income & Housing Cost Burdened             | 15.8%               | 19,000        |
| 80% AMI and less                                    | 17.4% <sup>26</sup> | 20,880        |
| Project/ building constraints                       | 20% <sup>27</sup>   | 24,000        |

The certified exemption estimates do not include continued sales of 30 gallon and below tanked water heaters, which are estimated at 10 percent per year.

Given that the purchase of Emergency Replacement Loaner water heaters will not displace zero NOx water heaters nor be installed permanently, numbers are not quantified below. However, in the nine-county Bay Area, current numbers of licensed contractors who would be eligible to purchase a limited number of NOx emitting water heaters (larger than 35 gallons tanked and less than 75,000 btu/hour) for emergency replacement loaners is listed below:<sup>28</sup>

- B (General Contractor License)      15,967
- C36 (Plumbing)                              1,762
- C20 (HVAC)                                    868

Lastly, for businesses with specialized applications and high hot water demand, many may already be utilizing water heaters above the 75,000 btu/hour threshold based on high hot water needs. However, estimated numbers of these businesses are listed below.

- Food service/restaurant facilities - approximately 2,427 food service buildings<sup>29</sup>
- Healthcare clinics and assisted living facilities - while not separate categories, BayREN buildings inventory estimates “Medical - Hospital & Clinic” and “Medical – Other” at 3,021 buildings in the Bay Area<sup>30</sup>

---

<sup>26</sup> These numbers are lower than what was previously presented at the February 2026 Stationary Source Committee. Updated results reflect income profile by each census tract (rather than at the county level) and calculations done separately for each household size category (rather than applying 4-person household income threshold to all owner-occupied households regardless of household size). For data citations for housing burden, federal poverty guidelines and area median income, please see **Appendix B**.

<sup>27</sup> Reasonable estimate based on program data and case studies citing prevalence of space and electrical constraints. See **Appendix C**.

<sup>28</sup> <https://www.cslb.ca.gov/onlineservices/dataportal/> accessed October 2025.

<sup>29</sup> <https://bayren-existing-buildings.mtcanalytics.org/>

<sup>30</sup> Ibid.

- Laundry, dry cleaner and laundromat - estimates in the Bay Area are not available.

Overall, staff expect the annual number of exemptions granted to specialized business applications to be low as compared to other exemption pathways as described above.

## Health Equity vs. Economic Equity Considerations

Staff considered both health equity and economic equity implications when evaluating future potential amendments to Rule 9-6. From a health equity perspective, the rule is intended to reduce NOx and PM<sub>2.5</sub> exposure, particularly in communities that have historically experienced higher pollution burdens. At the same time, staff evaluated potential economic impacts on low-income property owners and renters, including whether compliance costs could create financial hardship or housing instability. To address these considerations, the potential rule amendments incorporate targeted exemptions, phased implementation timelines, and other implementation safeguards intended to mitigate potential cost impacts and help preserve access to housing. **Table 8** below summarizes several of the key policy considerations staff evaluated in balancing these health and economic equity objectives.

**Table 8. Equity Considerations**

| Health Equity   |
|---|
| Reduced indoor and outdoor air pollution exposure       |
| Health-protective technology standards                  |
| Protections for renters and occupants                   |
| Fewer exemptions to maximize health benefits            |
| Prioritize reductions in overburdened communities       |
| Faster reduction of NOx and PM <sub>2.5</sub> emissions |
| Economic Equity   |
| Manage cost impacts for residents and businesses        |
| Phased-in compliance timelines                          |
| Protections for landlords and property owners           |
| Targeted exemptions to address barriers                 |
| Flexibility pathways for cost or technical constraints  |
| Incentives, rebates, and market support programs        |

For the zero NOx amendments to Rules 9-4 and 9-6 in 2023, staff evaluated ambient air quality and health impacts from covered appliances. Staff estimated NOx and PM<sub>2.5</sub> emissions from these sources, as well as their contributions to levels of fine particulate matter exposures.<sup>31</sup> Approximately 60 percent of average PM<sub>2.5</sub> exposure in the Bay Area associated with the target appliances results from secondary formation driven by NOx emissions. In general, because secondary PM<sub>2.5</sub> formation requires time and atmospheric transport, exposure to secondary PM<sub>2.5</sub> occurs at a regional scale rather than near the original emission sources. As a result, certain homes or locations that may forgo local emission reductions due to an exemption would still benefit from region-wide improvements in exposure if the flexibility amendments were implemented. **Figure 2**, below, depicts the modeled annual average baseline concentrations and reductions of secondary particulate matter attributed to the elimination of emissions associated with appliances impacted by the 2023 zero NOx amendments to Rules 9-4 and 9-6, which accrue on a regional basis.

**Figure 2. Baseline concentrations (left) and reductions (right) for secondary PM<sub>2.5</sub>**

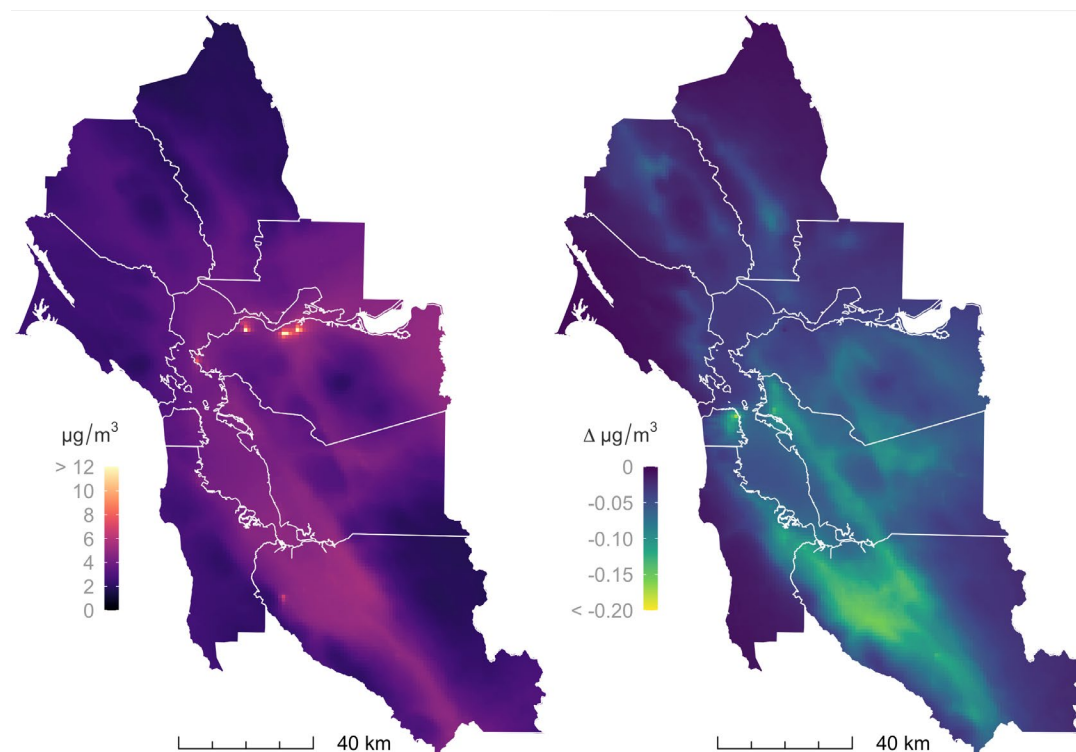

<sup>31</sup> [https://www.baaqmd.gov/~/\\_media/dotgov/files/rules/reg-9-rule-4-nitrogen-oxides-from-fan-type-residential-central-furnaces/2021-amendments/documents/20221220\\_sr\\_apppe\\_rg09040906-pdf.pdf?rev=d4b056153496491fad817c6d4a87df78&sc\\_lang=en](https://www.baaqmd.gov/~/_media/dotgov/files/rules/reg-9-rule-4-nitrogen-oxides-from-fan-type-residential-central-furnaces/2021-amendments/documents/20221220_sr_apppe_rg09040906-pdf.pdf?rev=d4b056153496491fad817c6d4a87df78&sc_lang=en)

Staff believe that it is too speculative at this time to make assumptions about the locations at which property owners will choose to utilize a certified exemption for project constraints or low-income qualification as there are many factors that would impact this decision. As summarized above, up to 38 percent of small water heaters could be eligible for an exemption or extension of the compliance timeline. However, due to the regional benefit of reduction of secondary fine particulate matter exposure and the focus of Rule 9-6 on the reduction of nitrogen oxides, a precursor for secondary particulate matter, staff does not believe that the flexibility amendments discussed in this document will result in a significantly different disparity in health benefits in existing overburdened communities. Additionally, the exemption pathways are intentionally designed as one-time exemptions so that any disparity does not exist in perpetuity. Staff intend for outreach related materials and the exemption portal to point all projects, including low-income property owners, to available incentives to mitigate any remaining equity concerns.

With regards to renters, under the Air District's flexibility concepts, exemptions would be provided in scenarios requiring significant construction including space and/or electrical constraints. Landlords would *not* be required to install zero NOx water heaters in scenarios that align with "substantial repair" exemptions, thus greatly decreasing "renoviction" risks.

Since the remaining projects that would be required will be more standard, average-cost projects, the risk of major pass-through costs will also be reduced as a result.

# Appendix A

## Electrical Constraints

In most homes, some electrical work will be needed to switch to a HPWH from an older gas water heater. This can range from minor work (e.g., simply installing a short length of new electrical conduit or outlet), to major work resulting in significant time and cost (e.g., extensive rewiring, electrical panel upsizing and potential utility service upgrades).

A minimum of 44 percent of single-family homes in the Bay Area is estimated to have electric panels with 200 amps,<sup>32</sup> which is considered to be the modern standard, and could fully electrify without panel upsizing.

32 percent of single-family and 59 percent of multifamily homes in California have panels of intermediate size (100 amps for single-family, 60 amps for multi-family)<sup>33</sup> and will likely require “right-sizing”, “watt diet” or panel optimization strategies (low-voltage appliances; circuit pausing/sharing; smart panels) to avoid panel and service upsizing in these homes. Newer 120-volt plug-in HPWHs (see **Figure 1A**) can also help mitigate the need for extensive electrical upgrades, particularly for smaller households with less hot water demand. For a small portion of homes, extensive electrical work likely cannot be avoided and would be especially costly, encompassing panel upsizing and in some cases, subsequent utility service upsizing. Statewide, 3 percent of single-family homes had panels smaller than 100 amps and 10 percent of multi-family homes had panels smaller than 60 amps (per dwelling unit) which will most likely require upsizing for electrification. In disadvantaged communities (DACs), the number of single-family homes with panels smaller than 100 amps is disproportionately higher at 8 percent.<sup>34</sup>

---

<sup>32</sup> NREL model, as described in Table 19. [https://www.baaqmd.gov/~media/files/community-health/building-appliance-implementation/task1\\_electrificationcosts-pdf.pdf?rev=3cb66a09f3094f94b35fa7fc90cfd4ec&sc\\_lang=en](https://www.baaqmd.gov/~media/files/community-health/building-appliance-implementation/task1_electrificationcosts-pdf.pdf?rev=3cb66a09f3094f94b35fa7fc90cfd4ec&sc_lang=en)

<sup>33</sup> Fournier, Eric et al. *Quantifying the electric service panel capacities of California's residential buildings*. 2024. <https://www.sciencedirect.com/science/article/pii/S0301421524002581>

<sup>34</sup> Ibid.

**Figure 1A. Heat Pump Water Heater (HPWH) configurations and wiring, siting and installation needs**

**240V HPWH**

- Most common type.
- Can operate in heat pump/efficiency mode for lowest cost or hybrid mode for faster hot water recovery.
- Most HPWH units are programmable to utility rates, demand response, and vacation modes.

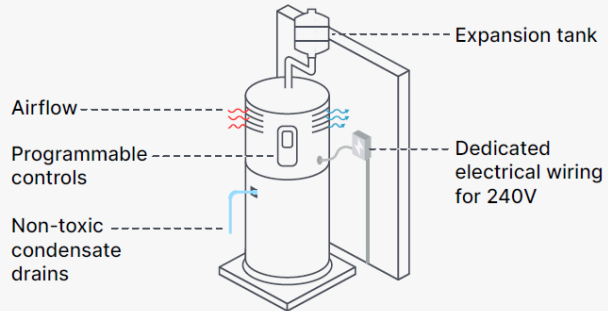

**120V Plug-in HPWH**

- Can reduce permitting time, costs, and inspection for new electrical service.
- Some models can be plugged into existing shared circuits.
- Helpful when running new wiring is too costly.
- Easier to install for emergency replacements.

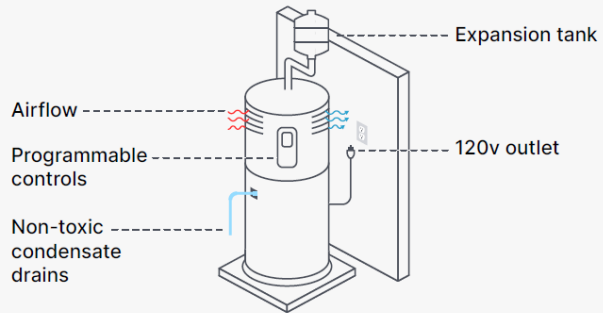

**Split System HPWH**

- Useful for tight spaces where ventilation, piping, and other construction limitations occur.
- Eliminates interior noise concerns and venting.
- Allows for flexibility of location for tanks, sizes, and plumbing connections.

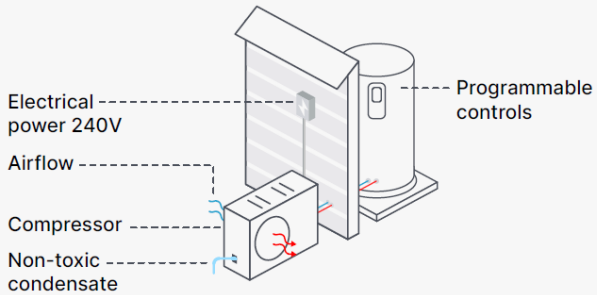

**Space Constraints**

HPWHs need adequate ventilation space as well as physical space (because of the integrated compressor unit, they are typically a bit taller than NOx-emitting units). Modifications to address space constraints range in costs.

Ventilation measures (air openings such as louvered doors, see **Figure 2A**) were mostly relatively low cost (average=\$208 and max=\$1,701) according to Palo Alto HPWH program

data.<sup>35</sup> Lower costs for these measures are also dependent upon having adequate ventilation space in the adjoining room or access to an outdoor wall.

**Figure 2A. Ways to circulate more air<sup>36</sup>**

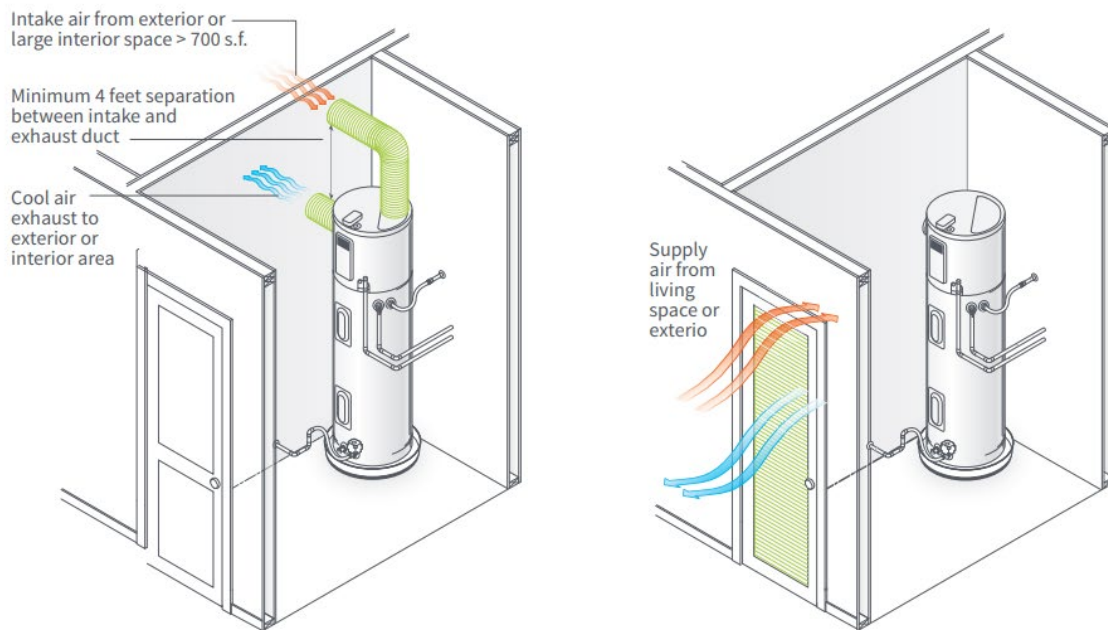

› **Ventilate with air ducts**

Heat pump water heaters can be connected to air ducts. In a smaller space, an air duct can supply warm air and a separate duct can remove cold air from the water heater outlet.

› **Ventilate with louvered doors**

Louvered doors are aesthetically pleasing without blocking air flow. Some water heaters have special requirements, but in small spaces you generally can use louvered doors for ventilation.

HPWHs, due to their slower recharge times, are typically upsized approximately 10-15 gallons compared to a gas water heater; these larger tanks, in addition to the integrated compressor, can lead to lack of physical space for the new HPWH if the existing location is a utility closet, a basement space with low ceilings, etc. Space reconfiguration or relocating the water heater can cause significant costs (average= \$1,287 and max= \$4,540), according to Palo Alto HPWH program data, as seen below in **Figure 3A**. Program data as illustrated in the **Figure 3A** bar chart shows that for individual projects, ventilation measures (red bars) were generally less expensive to add (<\$1,000) compared to space reconfiguration and carpentry measures (blue bars). Bars showing both red and blue

<sup>35</sup> Data provided by Palo Alto Utilities staff, September 2024. Note that the Palo Alto program is one of the few programs documenting detailed measures such as ventilation or carpentry measures, with hundreds of projects.

<sup>36</sup> <https://library.peninsulacleanenergy.com/m/c76176ab7d47195/original/Heat-Pump-Water-Heater-Space-and-Air-Guidance.pdf>

represent projects and costs that deployed both ventilation measures and space reconfiguration or carpentry measures.

**Figure 3A. Palo Alto HPWH Program: Additional Space Constraint Costs (\$) for Space Reconfiguration, Carpentry, and Ventilation Measures<sup>37</sup>**

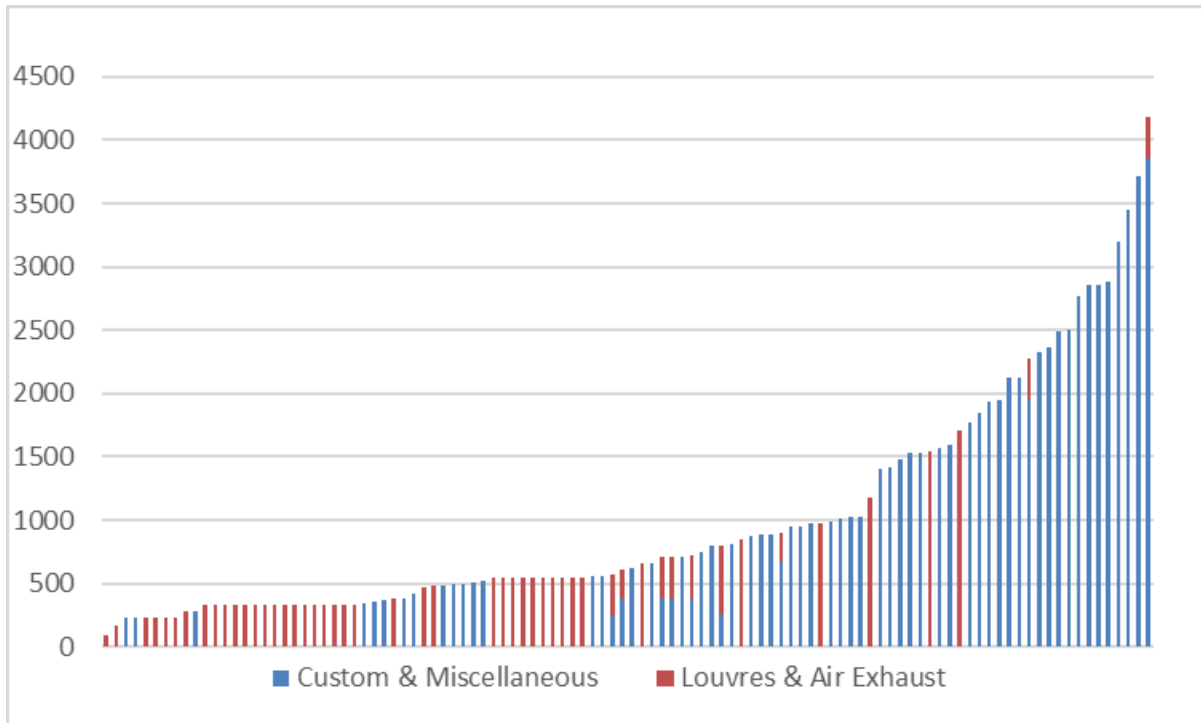

HPWH solutions for small spaces are emerging. Split-system HPWHs offer an unattached, outside condenser/heat pump (see **Figure 1A**) but there are fewer and less common market options.

<sup>37</sup> Data provided by Palo Alto Utilities staff, September 2024. Note that the Palo Alto program is one of the few programs documenting detailed measures with hundreds of projects.

# Appendix B

## References for Income Qualified Calculations

For 2025 values of 250 percent Federal Poverty Guidelines for each household size:

<https://aspe.hhs.gov/sites/default/files/documents/dd73d4f00d8a819d10b2fdb70d254f7b/detail-guidelines-2025.pdf>

For 2023 5-year American Community Service Tables:

B25009 - tenure by household size for owner and renter occupied homes - use owner occupied:

[https://data.census.gov/table/ACSDT5Y2023.B25009?q=050XX00US06001\\$1400000,06013\\$1400000,06041\\$1400000,06055\\$1400000,06075\\$1400000,06081\\$1400000,06085\\$1400000,06095\\$1400000,06097\\$1400000](https://data.census.gov/table/ACSDT5Y2023.B25009?q=050XX00US06001$1400000,06013$1400000,06041$1400000,06055$1400000,06075$1400000,06081$1400000,06085$1400000,06095$1400000,06097$1400000)

B25118 - number of households in different income bins for owner- and renter-occupied homes - used owner-occupied housing units: Tenure by Household Income in the Past 12 Months (in 2023 Inflation-Adjusted Dollars):

[https://data.census.gov/table/ACSDT5Y2023.B25118?q=California+Income+and+Poverty&t=Owner/Renter+\(Householder\)+Characteristics&g=050XX00US06001,06013,06041,06055,06075,06081,06085,06095,06097&y=2023](https://data.census.gov/table/ACSDT5Y2023.B25118?q=California+Income+and+Poverty&t=Owner/Renter+(Householder)+Characteristics&g=050XX00US06001,06013,06041,06055,06075,06081,06085,06095,06097&y=2023)

For Area Median Income (AMI) for each county and household size:

<https://www.hcd.ca.gov/sites/default/files/docs/grants-and-funding/income-limits-2023.pdf>

## Appendix C

### Sources for Project Constraint Estimates

| <b>Program/ Source</b>   | <b>Geographic Scope</b> | <b>Constraint</b>  | <b>Prevalence</b>                |
|--|-------------------------|--|----------------------------------|
| <a href="#">Palo Alto</a>  | Palo Alto               | Space, electrical, drainage measures >\$1500 per project   | 15%                              |
| <a href="#">TECH / NBI 120V HPWH study</a>   | Statewide               | Space constraint. (Note: program did not use any space ventilation measures e.g. louvered doors) | 28%                              |
| <a href="#">UCLA <i>Quantifying the electric service panel capacities of California's residential buildings.</i></a> | Statewide               | Electrical   | 3% SF, 10% MF                    |
| <a href="#">BayREN Home Energy Score Audits (included water heater location information)</a>                         | Santa Clara Co.         | Space: interior utility closets (some basements may also be constrained)                         | 4% interior closet, 20% Basement |

# Appendix D

## Average Estimated Upfront and Incremental Costs

The costs presented below are general estimations and are not meant to represent exact costs for any specific project or installation. Actual costs will vary based on site conditions, equipment size, and installation requirements.

| Unit Type               | Upfront Installation Cost | Long-Term Energy Cost |
|-------------------------|---------------------------|-----------------------|
| 35-gal gas water heat   | Moderate                  | Moderate-low          |
| 75-gal gas water heater | Moderate                  | Moderate-high         |
| Gas tankless            | Moderate-high             | Moderate              |
| 120-volt Plug-in HPWH   | Moderate-high             | Moderate-low          |
| Standard HPWH           | Moderate-high             | Low-moderate          |
| Electric tankless       | High                      | High                  |

**Figure 4A Illustrative Relative Costs Trends by Water Heater Technology<sup>38</sup>**

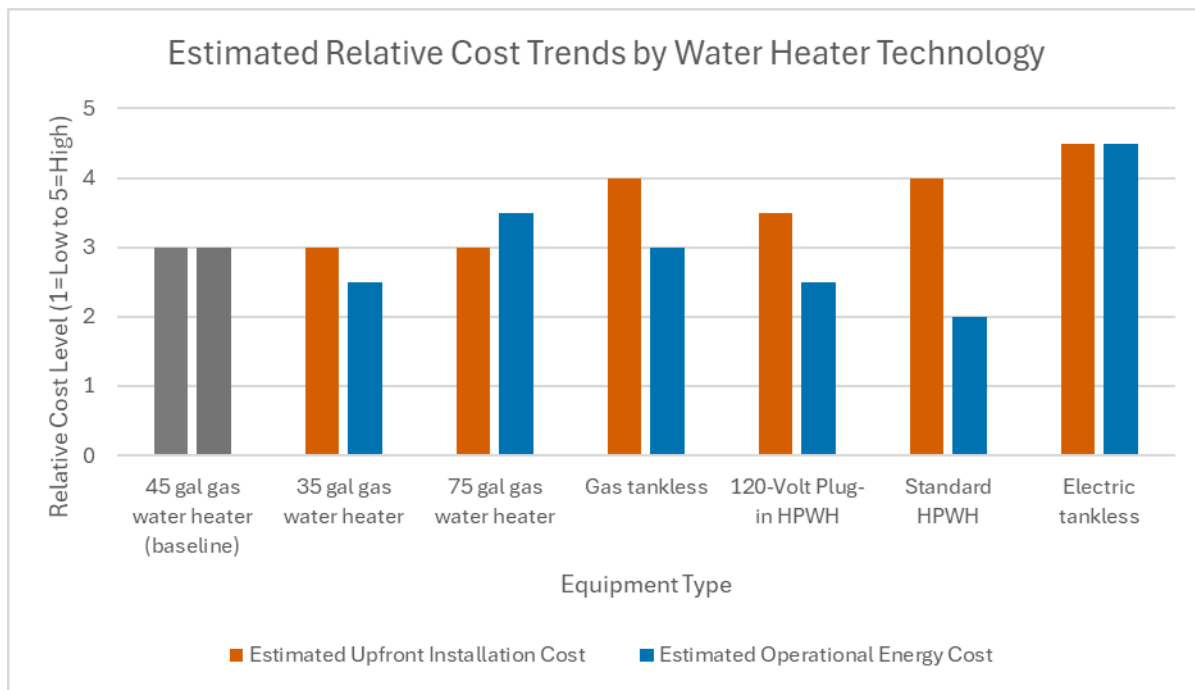

<sup>38</sup> Adapted from *ibid* 15; values are illustrative and reflect staff interpretation of available data



# Rule 9-6: Flexibility and Affordability Amendments for Zero NOx Water Heaters

## Board of Directors Meeting

May 6, 2026

Jennifer Lam  
Manager  
Regulatory Development Division

# Presentation Outline

---

- I. Rule 9-6 Background and Overview
- II. Need for Flexibilities
- III. Summary of Potential 9-6 Amendments
- IV. Common Questions and Concerns
- V. Next Steps and Discussion

# Recommended Action

---

Discuss and provide input on staff recommendations or alternative approaches.

# Abbreviations

---

**AMI:** Area median income

**BTU/hr:** British thermal units per hour;  
measure of heat energy

**CARE:** California Alternate Rates for  
Energy

**CEC:** California Energy Commission

**CEQA:** California Environmental  
Quality Act

**CPUC:** California Public Utilities  
Commission

 Bay Area Air District

**FERA:** Family Electric Rate Assistance  
Program

**HPWH:** Heat pump water heater

**M:** Million

**NOx:** Nitrogen Oxides

**PG&E:** Pacific Gas and Electric

**PM:** Particulate matter

**PM<sub>2.5</sub>:** Fine particulate matter

**WIC:** Women, Infants and Children  
(supplemental nutrition program)

# Part I. Why did Air District Board of Directors adopt zero NOx standards for furnaces and water heaters?



# NOx Emissions from Buildings

2019 Air District NOx Emissions (tons)

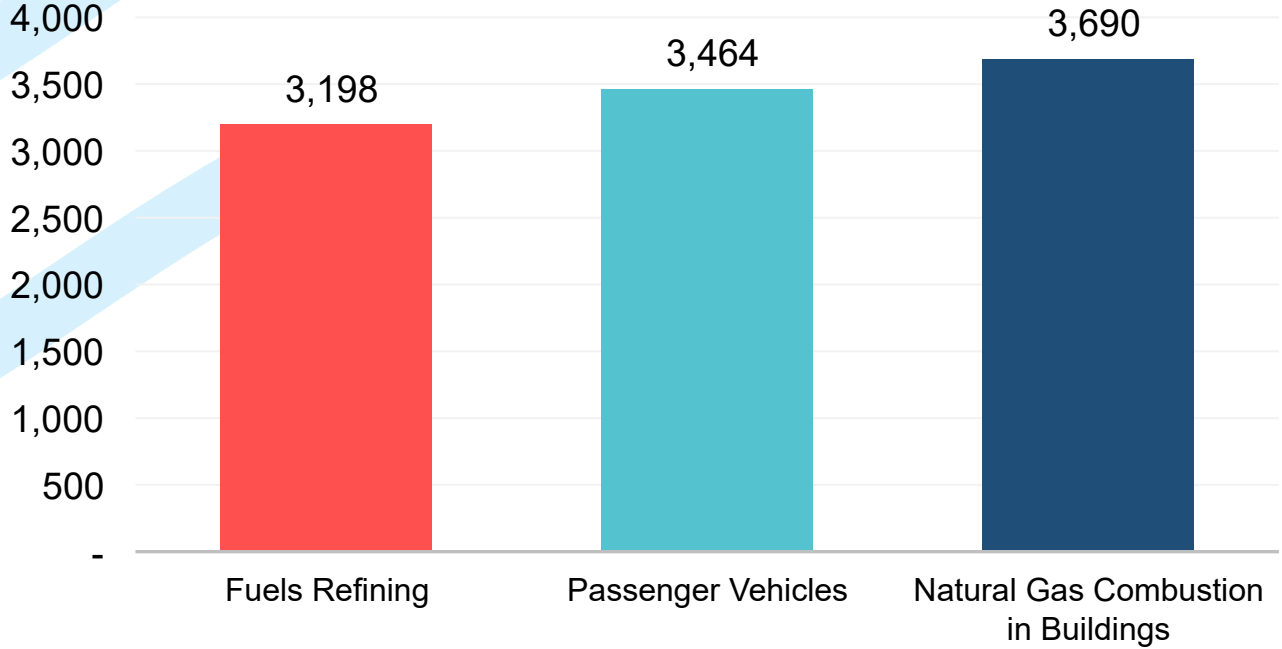

Air District Residential Natural Gas Combustion NOx Emissions (2019)

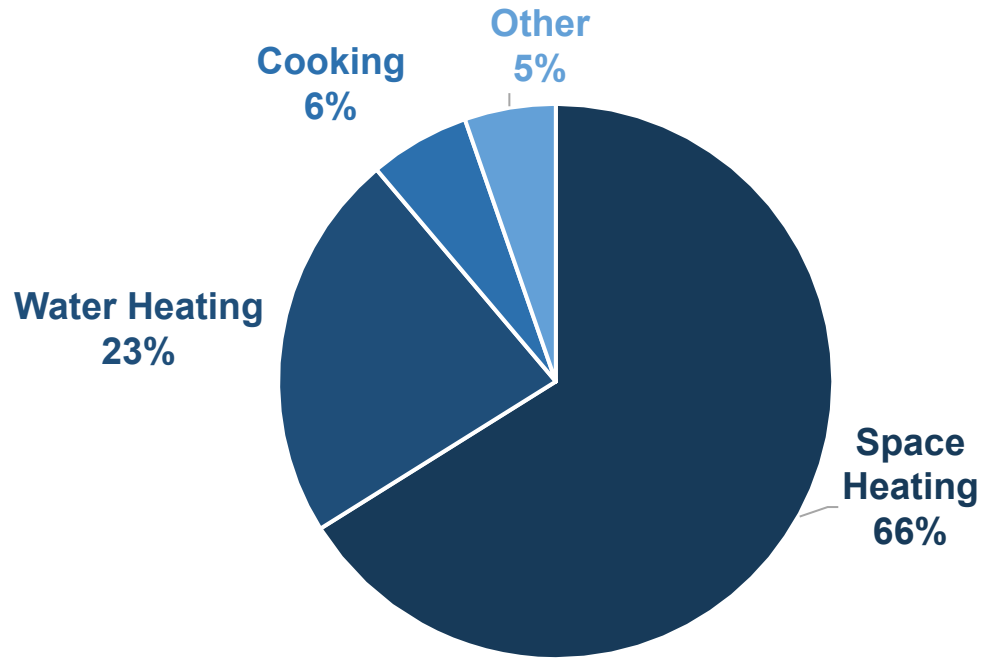

# Major Health Benefits from Rules 9-4 and 9-6

These appliance rules help improve regional air quality by reducing pollution from furnaces and water heaters.

## Cleaner outdoor air

Less NOx and PM<sub>2.5</sub> from venting

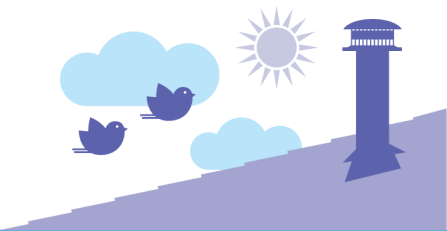

Lower pollution means lower exposure to fine particles (PM<sub>2.5</sub>).

## Cleaner Bay Area communities

Biggest PM<sub>2.5</sub> reductions in communities of color and overburdened neighborhoods



Reducing PM<sub>2.5</sub> and NOx exposure can prevent dozens of early deaths every year in the Bay Area.

## Up to 85 early deaths avoided

each year from cleaner air



Health improvements from cleaner air avert unnecessary costs from health impacts.

## Up to \$890M

Annual health benefits saved in avoided illnesses, hospital visits, and early deaths



# Zero NOx Water Heater Technology is Widely Available

- Diverse technology options available for installation
- 20,000+ units installed in the Bay Area and growing

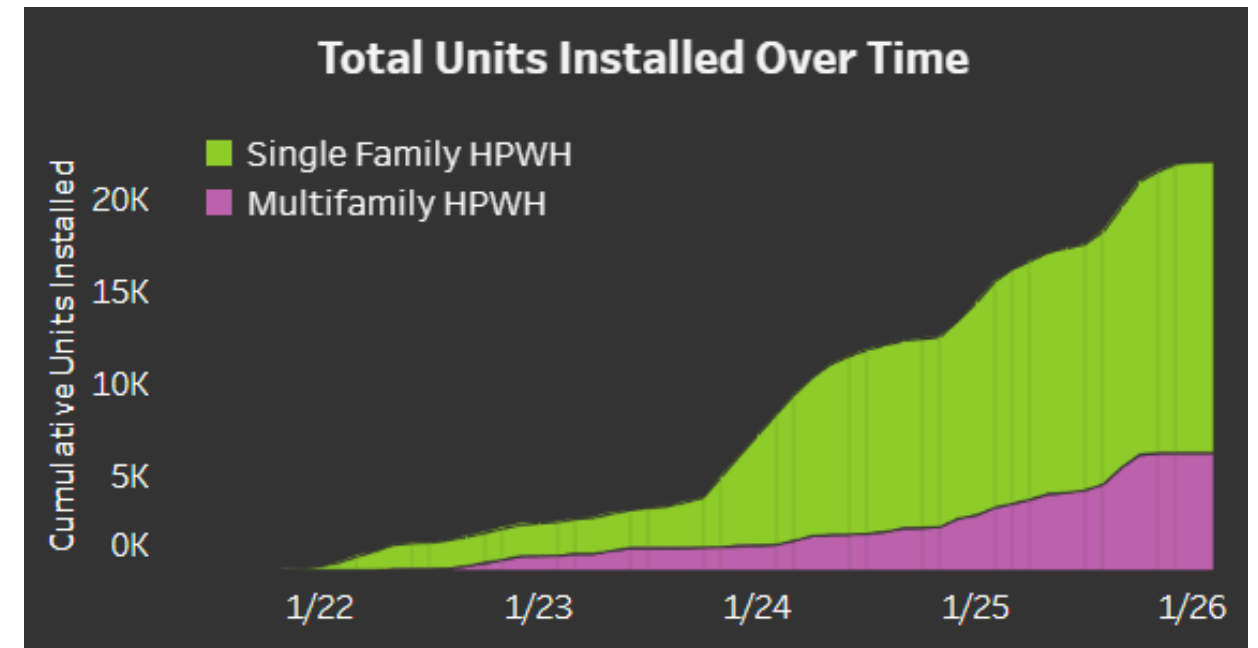

Source: [TECH Public Reporting Heat Pump Data Visuals](#)

# Zero NOx Standards – 2023 Amendments

- NOx standards within Rule 9-4 (furnaces) and Rule 9-6 (water heaters) have been in place for almost four decades
- Standards have **gradual phase-in**: all new sales or installations of units manufactured after compliance dates

| <b>1/1/2027</b> | <b>Water heaters less than 75,000 BTU/hr</b>  |
|-----------------|---|
| 1/1/2029        | All applicable natural gas-fired furnaces (e.g., residential and commercial; including direct-vent units) |
| 1/1/2031        | Water heaters 75,000 to 2 million BTU/hr  |

- Staff update to the Board due two years prior to each compliance date

# Implementation Working Group Phase 1 Small Water Heaters



**Technical  
Readiness**



**Equitable  
Transition**

**40+ members**

**Environmental  
Justice and  
Community-  
Based  
Organizations**

**Subject Matter  
Experts on  
Energy,  
Buildings, and  
Technology**

**Regional/Local  
Government  
and State  
Agencies**

**Labor and  
Trade  
Organizations**

**Utilities and  
Community  
Choice  
Aggregators**

## Meetings

**6** Public  
Plenary

**5** Steering  
Committee

**5** Technical  
Subcommittee

**5** Equity  
Subcommittee

# Board and Committee Timeline

| Date              | Venue                       | Summary  |
|-------------------|-----------------------------|--|
| March 15, 2023    | Board of Directors          | Adoption of zero NOx amendments to Rules 9-4 & 9-6<br>Board directed staff to come back with a Rule 9-6 implementation report in 2024  |
| December 4, 2024  | Board of Directors          | Informational report on staff’s research and a summary of IWG findings for Rule 9-6 implementation   |
| October 24, 2025  | Public Comment Period       | Public Release of Rule 9-6 Concepts Paper (flexibility options) informed by Phase I of the IWG   |
| December 10, 2025 | Stationary Source Committee | Presentation on potential flexibility amendments based on affordability and availability issues for Rule 9-6<br>Committee directed staff to come back with information on possible exemptions for low-income property owners   |
| February 11, 2026 | Stationary Source Committee | Presentation on the definition of “low-income” including considerations for housing cost burden and how much it costs to help low-income households switch to zero NOx water heaters<br>Committee directed staff to return in May 2026 with a full set of proposed changes so the full Board can give clear directions on how to proceed with the rule |

# Release of the Regulatory Overview

---



- Highlights steps taken since the adoption of the 2023 amendments to Rule 9-6
- Additional background information and details on flexibility and affordability amendments
- Released April 13, 2026

# Part II. Why do Rule 9-6 zero NOx standards for water heaters need flexibilities?

# Space Constraints

- HPWHs take up more space
  - *confined spaces (e.g. closets) may not physically fit the larger HPWH*
- HPWHs need sufficient air to pull heat from; most manufacturers recommend at least 700 ft<sup>3</sup> of space
  - *some installs can use venting measures to allow installs in smaller spaces*
- Smaller HPWH technology still under development

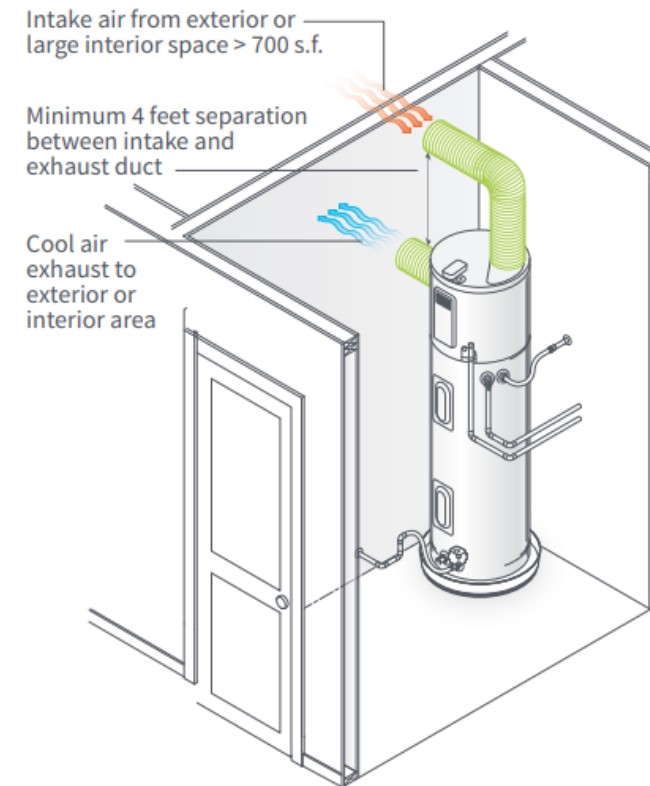

> Ventilate with air ducts

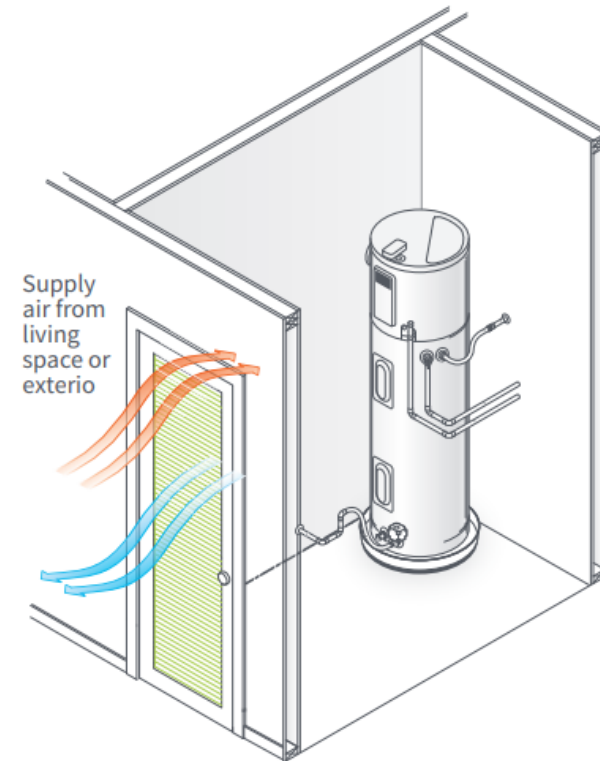

> Ventilate with louvered doors

Source: [www.peninsulacleanenergy.com](http://www.peninsulacleanenergy.com)

# Electrical Constraints

- In some cases, complex electrical work and panel and utility service upsizing can result in higher installation costs and long timelines
  - 120-volt plug-in HPWHs can help for some homes
- “Watt diet” or panel optimization strategies could be deployed in 32% of single-family homes and 59% of multi-family homes in California to avoid panel and service upsizing

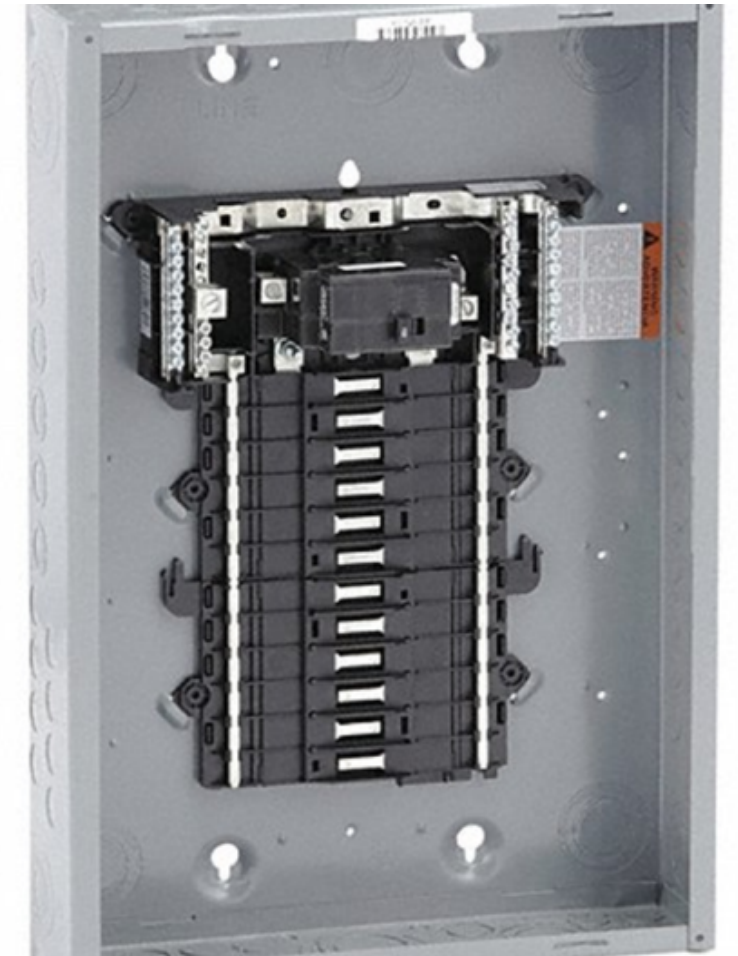

Source: Granger.com

# Costs Associated with Implementation

Zero NOx Average Additional (Incremental) Costs:

- Approximately \$3,500 (\$600-\$1,600 additional retail cost for equipment, plus installation)
- Rebates where available will offset some incremental costs
- Operational cost savings may offset some upfront incremental costs over time
- Median incremental costs are similar to the average



# Cost Distribution of Replacement Projects

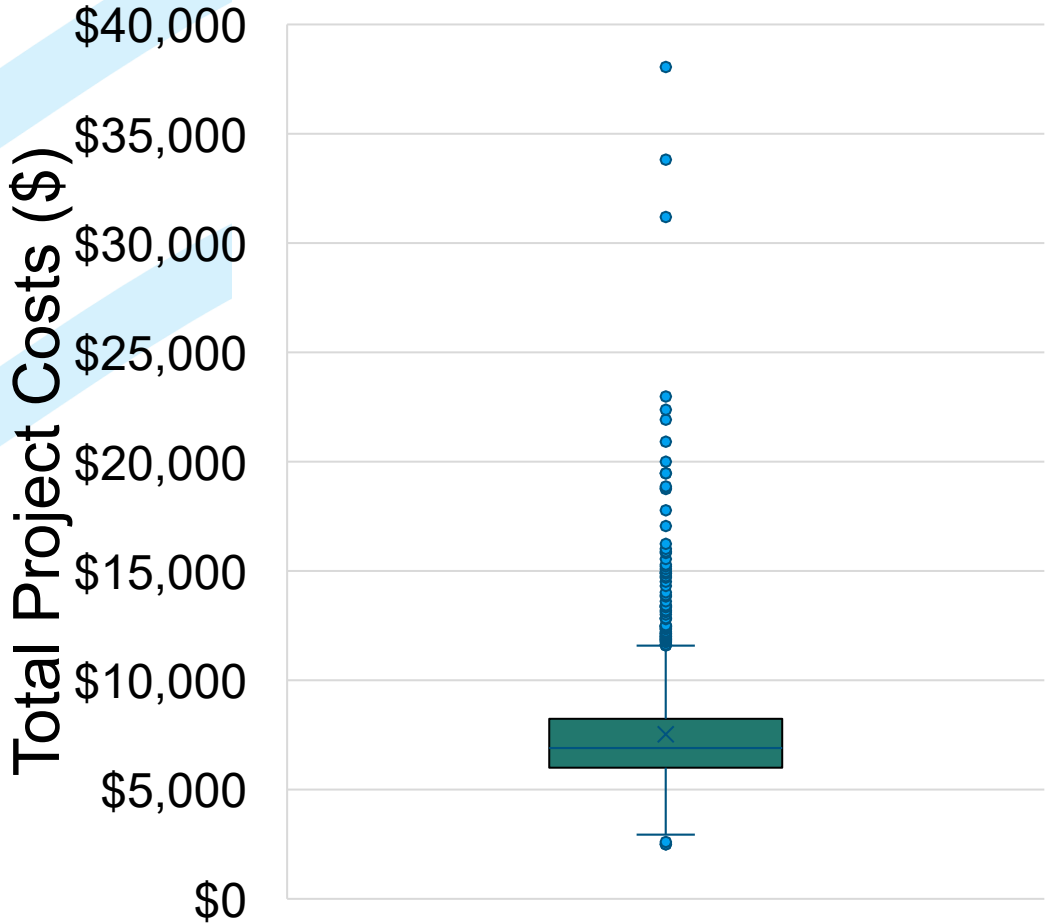

- Majority of ~4,000 Bay Area HPWH projects evaluated were close to the median and average of ~\$7,000 for total equipment and install costs
- Program data showed some outliers and high-cost projects due to:
  - Electrical upgrades
  - Water heater relocation

Source: Appendix A of Staff Report: Informational Update on Rule 9-6 & TECH Clean CA  
December 2023

# Incentive Availability

- Federal, State and local incentives are currently available
- Not enough current funding to cover incremental costs for all Bay Area low-income homes beyond the next few years

**THE SWITCH IS ON**

Zipcode  Water Heating

**SEARCH**

**SEARCH**  
for local incentives by location, specialty and more.

**CONNECT**  
with trusted contractors, in our contractor directory

**(-) HEAT PUMP WATER HEATER**

**INCENTIVE LOOKUP FOR CUSTOMERS**

**INCENTIVE TYPE** ▾

REBATE  
 FINANCING

**EQUIPMENT TYPE** ▾

Heat Pump Water Heater ▾

**INCENTIVE PROVIDER** ▾

Source: [www.switchison.org](http://www.switchison.org)

# Part III. What are the proposed flexibility exemptions?



# Objectives of Exemptions

1. Address **affordability** and the **drivers** of high cost
2. **Simple** and **automated** process
3. Continued sales for equipment lacking zero NOx options



Source: istockphoto.com

# Categories for Rule 9-6 Compliance

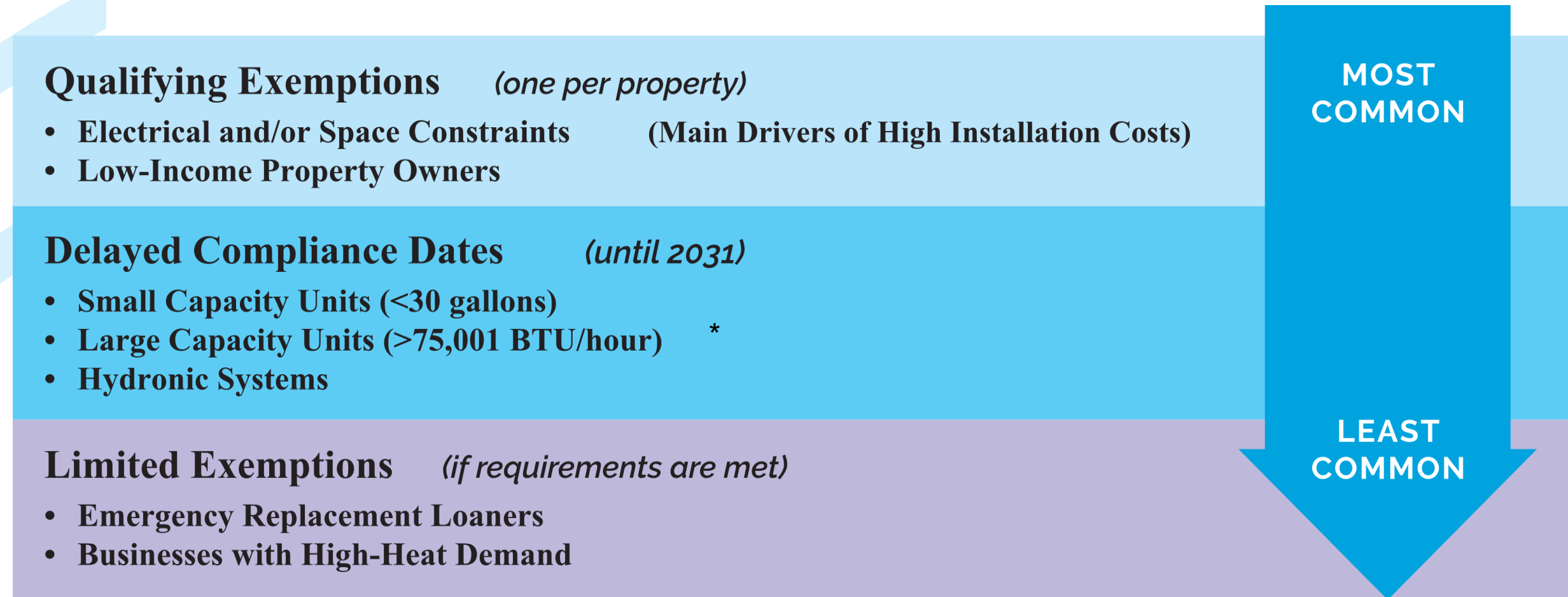

\*Note: Large capacity unit compliance date is existing requirement, not planned change

# Total Estimated Exemptions

- Staff estimate up to 38% of water heater installations would qualify for exemptions

ESTIMATED ANNUAL DISTRIBUTION OF EXEMPTION PATHWAYS

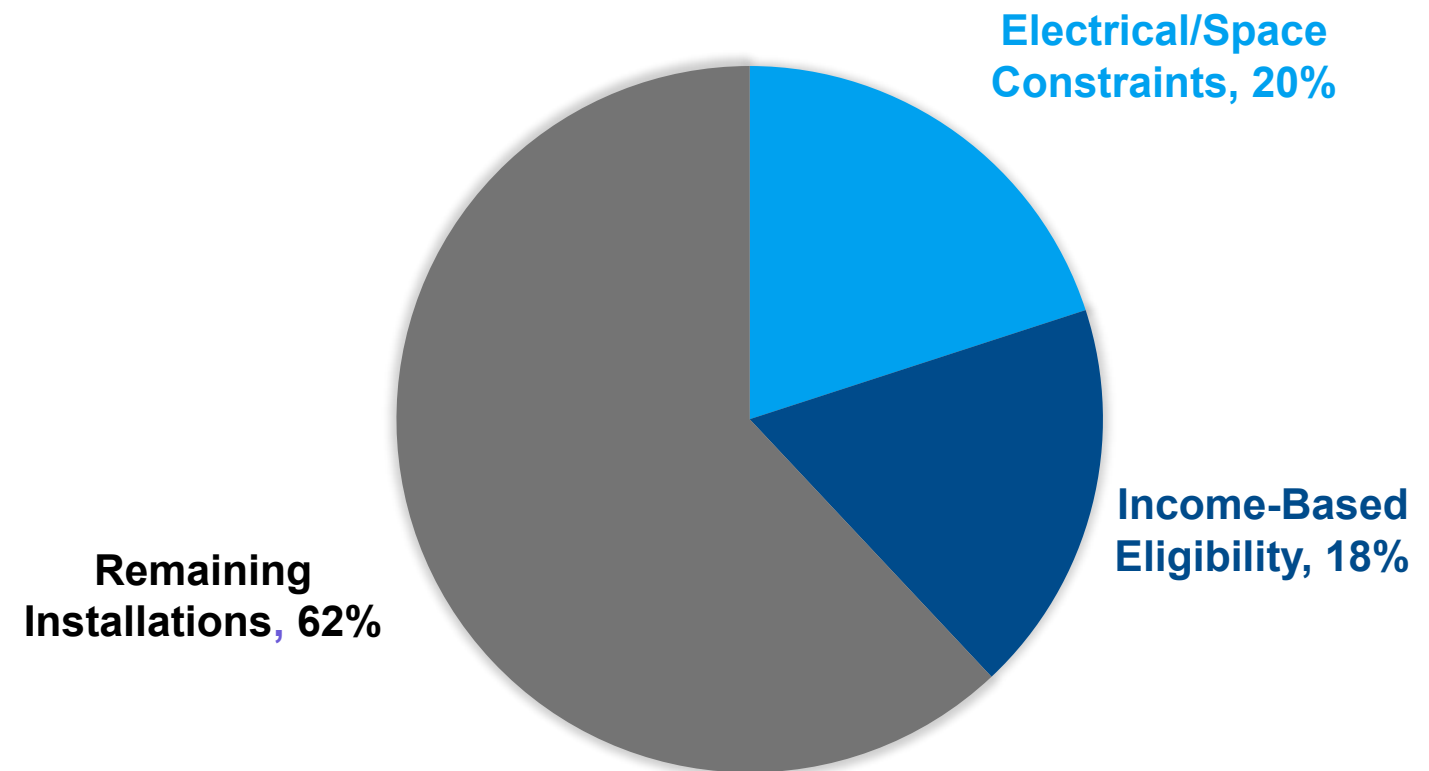

# Project Cost Impacts

- Remaining projects will be “standard” installs
  - Incremental costs expected to remain ~\$3,500
- Majority of project costs due to extra labor required (new electrical and drain lines; cap gas line; etc.)



Source: [www.istockphoto.com](http://www.istockphoto.com)

# Public Health Impacts

- Exemption locations are uncertain at this time
- Maintains regional benefit due to the reduction on  $PM_{2.5}$
- Emissions reductions will take longer to achieve due to exemptions

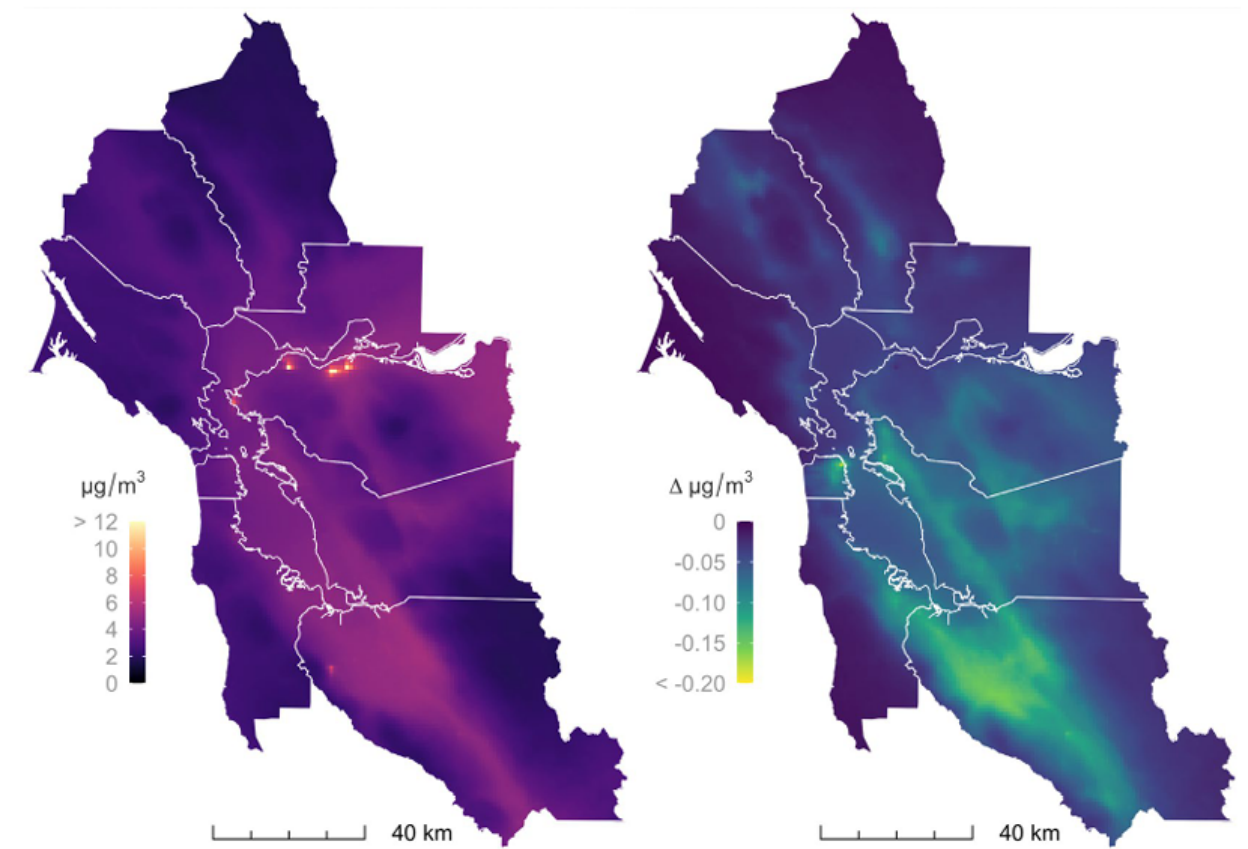

Baseline concentrations (left) and reductions (right) for secondary  $PM_{2.5}$  (Source: 2023 Rule 9-6 Staff Report)

# Low-Income Qualified Property Owner

---

## Defined as:

- Property owners that are either low-income program participants (250% Federal Poverty Guidelines) OR
- Housing cost burdened (annual mortgage and property taxes  $\geq$ 28% of gross income).

## Pros:

- Streamlines determination and customer experience (no annual county- or household-specific income thresholds)
- Provides relief for potential affordability issue
- Aligns with programs e.g. FERA, CARE, WIC

## Cons:

- Other designations e.g. 80% AMI more typically used by some HPWH incentive programs

# Project Specific Exemptions Require Contractor

## **Pros:** Contractors will:

- Have knowledge needed to accurately evaluate technical options
- Be more capable of staying up-to-date on growing technology landscape

## **Cons:**

- May increase time and costs for property owners who may normally self-install



Source: [istockphoto.com](https://www.istockphoto.com)

# One-time Exemption Per Project Address

---

## Pro:

- Provides building owner ~13 years to prepare for zero NOx installation for next water heater, starting from 2027

## Con:

- May still have high costs upon future installation

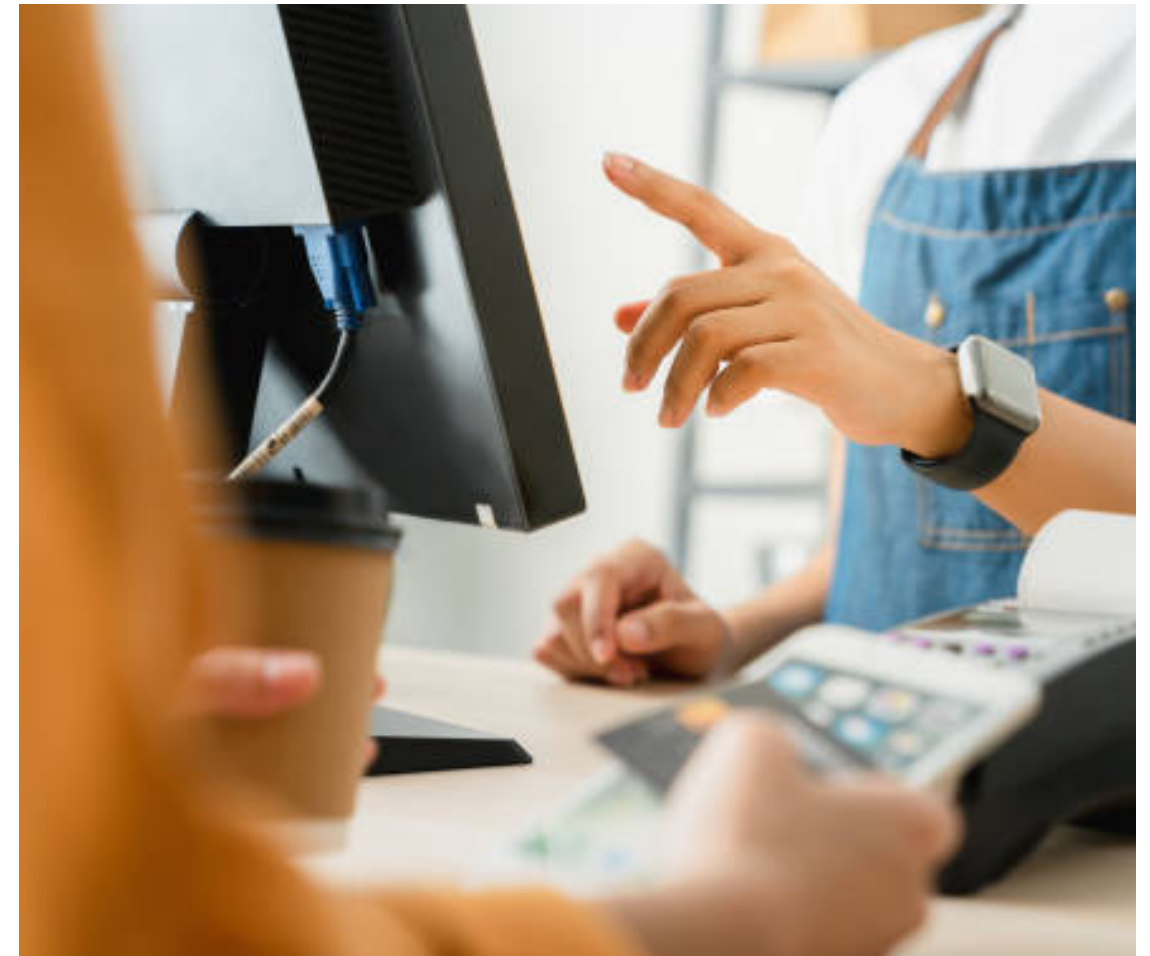

Source: istockphoto.com

# Processing Fee for Exemptions

- No processing fee for low-income exemptions, only for project-specific exemptions
- Consideration of increased fee to fund low-income rebates

Cost recovery:

$$\begin{array}{ccc} \text{Annual Implementation Expenses} & \div & \text{Expected Annual Project Specific Exemptions} \\ \sim \$3 \text{ million} & & \sim 24,000 \\ & & = \\ & & \text{Processing Fee} \\ & & \$125 \end{array}$$

# Delay to October 1, 2027 Effective Date

---

## **Pros:** Provides time for:

- Development and testing of exemption system
- Better alignment with retailers, manufacturers, distributors & contractors
- Increased training of staff & participating stakeholders
- More property owner outreach

## **Cons:**

- Emissions benefits deferred 9 months

# Part IV. Common Questions and Concerns



# Stoves or Whole Home Electrification?

Rules 9-4 and 9-6:

- DO NOT require immediate replacement of working appliances
- DO NOT affect stoves, clothes dryers, fireplaces, or any other gas appliance
- DO NOT require whole home electrification or discontinuing gas service
- DO focus on reducing NOx emissions that impact regional air quality

**Air District Residential Natural Gas Combustion NOx Emissions (2019)**

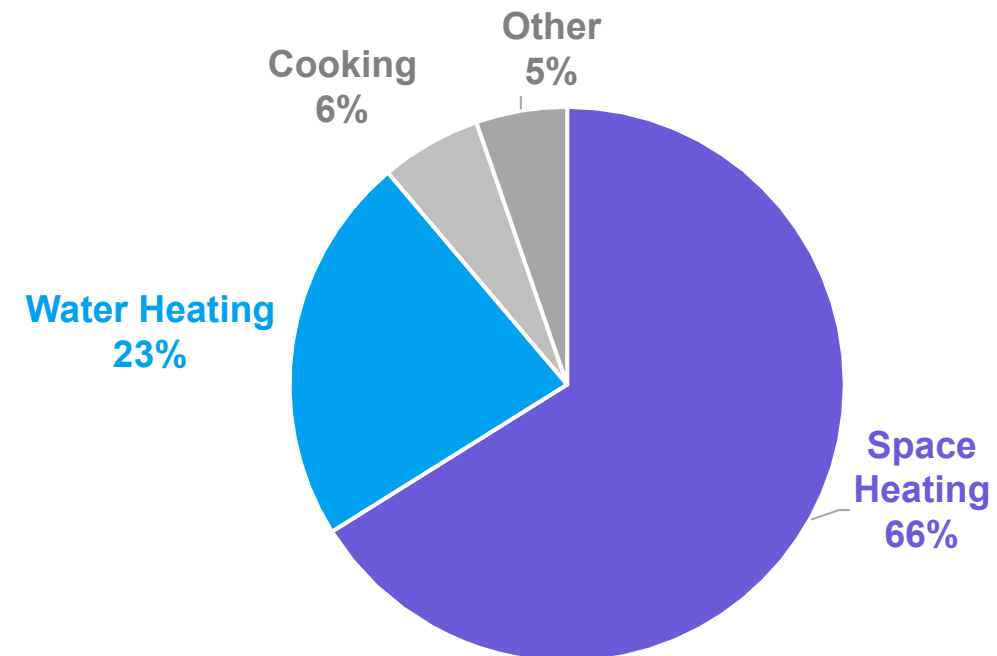

# Socioeconomic Impacts?

---

- The Air District completed an extensive review of the socioeconomic, environmental, and electric grid impacts of the rules in 2022, including:

Direct impacts of increased compliance costs

Potential equity impacts at the household level

Potential shifts in consumer spending and job losses

Impacts to electric grid capacity, reliability and related costs

Air District costs to implement the proposals

- Stakeholders consider this analysis to be a good model for enhanced regulatory analyses going forward
- We will update this analysis with new information for the affordability amendments

# High Expense to Property Owners?

---

- Exemptions for space and electrical constraints are designed to avoid situations that would result in high-cost installations
  - The incremental cost is a one-time cost of \$3,500
  - Existing incentives and rebates will bring that cost down, especially for low-income property owners
- The low-income exemption is designed to help property owners who cannot afford these costs, even with available incentives
- Remaining non-exempted installations will be low or moderate cost and for those who can better afford it
- The health benefits from these one-time upgrades last forever

# Panel and Service Upsizing?

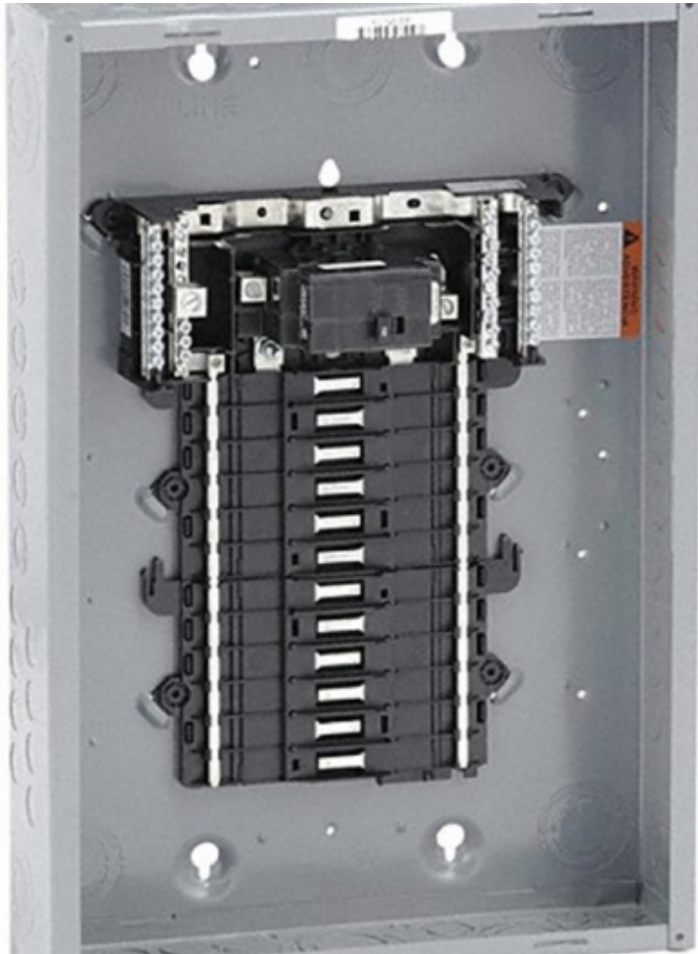

Source: Granger.com

## Requirements for Contractor Certified Exemption for Electrical Constraints:

- The home/building has knob-and-tube wiring.
- The electrical panel is <100 amps (single-family) or <60 amps (multi-family)
- The electrical panel does not have enough circuit or breaker space
- New 240v connection requires more than 50 feet of wiring/conduit
- Utility service upsizing is needed

# Housing Costs and Displacement Impacts?



All-electric new construction is less expensive



Exemptions address all identified significant cost/affordability drivers



Cities where most renters live have strongest renter protections



Exemption pathways will limit need for large-scale renovations that could cause displacement

# Equity Concerns with Low-Income Exemption?

## Property Owners

- The exemption only applies to property owners; there will still be substantial conversion to clean equipment in overburdened communities

## Regional Benefit

- A large part of the health benefit from the rule is from NO<sub>x</sub> that converts to PM over time; these health benefits accrue regionally

## Rebate Availability

- Low-income households have greater access to rebates, and so many may not need to use the exemption. The exemption website will connect them with personalized information about available funding. We will continue to advocate for more rebate funding, especially for low-income property owners

# Electric Grid Readiness and Reliability?

- CEC, CPUC and PG&E have accounted for added electric loads in their planning processes
- Appliance replacements will phase in over time
- HPWHs can store hot water and energy for several hours
- Like HPWHs, many new gas water heaters require electricity to operate
- Most outages are short-term and caused by weather disturbances



## Grid Reliability and Interconnection Challenges

Bay Area Air Quality Management District

### Bay Area Air Quality Management District

### Electric Infrastructure Impacts from Proposed Zero NOx Standards

November 3, 2022

Ari Gold-Parker  
John de Villier  
Amber Mahone  
44 Montgomery Street, Suite 1500  
San Francisco, CA 94104  
amber@ethree.com

prepared by





Rincon Consultants, Inc.  
449 15th Street, Suite 303  
Oakland, California 94612

Energy + Environmental Economics (E3), Inc.  
44 Montgomery Street, Suite 1500  
San Francisco, California 94104

September 2024

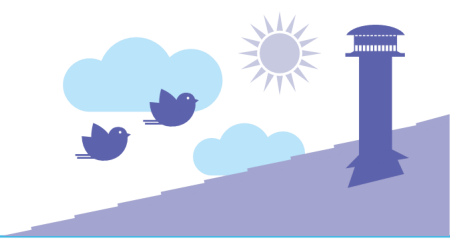

# Major Health Benefits from Rules 9-4 and 9-6

|   |   |
|---|---|
| <p>These appliance rules help improve regional air quality by reducing pollution from furnaces and water heaters.</p> | <p><b>Cleaner outdoor air</b><br/>Less NOx and PM<sub>2.5</sub> from venting</p>   |
| <p>Lower pollution means lower exposure to fine particles (PM<sub>2.5</sub>).</p>                                     | <p><b>Cleaner Bay Area communities</b><br/>Biggest PM<sub>2.5</sub> reductions in communities of color and overburdened neighborhoods</p>  |
| <p>Reducing PM<sub>2.5</sub> and NOx exposure can prevent dozens of early deaths every year in the Bay Area.</p>      | <p><b>Up to 85 early deaths avoided</b><br/>each year from cleaner air</p>    |
| <p>Health improvements from cleaner air avert unnecessary costs from health impacts.</p>                              | <p><b>Up to \$890M</b><br/>Annual health benefits saved in avoided illnesses, hospital visits, and early deaths</p>                      |

# Part V. Next Steps and Discussion



# Public Awareness Campaign Overview

---

- Campaign to increase awareness of the health impacts of NOx-emitting appliances, benefits of zero NOx alternatives, and key steps for replacement
- Multi-channel outreach: contractors, municipalities, media, property owners, small businesses, social media, and local advertising
- Baseline and tracking surveys to measure awareness of zero NOx appliances and Building Appliance Rules

# Public Awareness Campaign Timeline

---

*Multi-phase communications plan to educate and engage all audiences*

## **Phase I – Now through fall**

- Develop clear, audience-specific messaging focused on benefits of switching to zero NOx appliances
- Conduct baseline awareness survey (April–June)
- Launch media, contractor, and social outreach

## **Phase II – Fall through early 2027 (post-Board action)**

- Launch local advertising campaign
- Expand outreach, including door-to-door, with clear timelines and calls to action

## **Phase III – 2027 and beyond**

- Continuation of advertising, public relations, stakeholder, and social media outreach

# Immediate Next Steps

---

## **Board Meeting for Vote October 2026 (*targeted*)**

*In advance, Staff will release:*

- Proposed Rule Language
- Staff Report
- Updated CEQA Analysis
- Updated Socioeconomic Impacts Report

As compared to 2023 amendments

# Summary of Key Recommendations

---

## **Discuss and provide input on staff recommendations:**

- Low-income exemption based on participation in income-qualified program or housing cost burden
- Project-specific exemptions requiring contractor participation
- One project-specific exemption per address
- Assess a moderate processing fee for project-specific exemptions to recover costs of the program
- Provide for a 9-month delay to develop exemption process and conduct outreach

# Conclusion

---

**For more information:**

**[www.baaqmd.gov/buildingappliances](http://www.baaqmd.gov/buildingappliances)**