

**Bay Area Air Quality Management District**

939 Ellis Street  
San Francisco, CA 94109  
(415) 771-6000

**Permit Evaluation  
and  
Statement of Basis  
for  
Minor Revision of**

**MAJOR FACILITY REVIEW PERMIT**

for

**Lehigh Southwest Cement Company**

**Facility #A0017**

**Facility Address:**

24001 Stevens Creek Boulevard  
Cupertino, CA 95014

**Mailing Address:**

24001 Stevens Creek Boulevard  
Cupertino, CA 95014

November 2011

Application Engineers: Thu Bui  
Site Engineer: Thu Bui

Application: 23663

## TABLE OF CONTENTS

A.	Background.....	3
B.	Facility Description.....	5
C.	Permit Content .....	5
I.	Standard Conditions .....	5
II.	Equipment .....	6
III.	Generally Applicable Requirements.....	7
IV.	Source-Specific Applicable Requirements, Applicable Limits & Compliance Monitoring Requirements.....	7
V.	Schedule of Compliance.....	23
VI.	Permit Conditions.....	24
VII.	Applicable Limits and Compliance Monitoring Requirements.....	29
VIII.	Permit Shield: .....	29
IX.	Glossary.....	29
X.	Revision History.....	29
XII.	State Implementation Plan.....	30
D.	Alternate Operating Scenarios: .....	30
E.	Compliance Status: .....	30
F.	Differences between the Application and the Proposed Permit:.....	30
	Appendix A -- BAAQMD Compliance Report.....	31
	Appendix B -- Glossary.....	41
	Appendix C – NSR Permit Evaluations .....	46
	Appendix D – Compliance Assurance monitoring (CAM) Analysis.....	58

## **Title V Statement of Basis**

### **A. Background**

This facility is subject to the Operating Permit requirements of Title V of the federal Clean Air Act, Part 70 of Title 40 of the Code of Federal Regulations (CFR), and BAAQMD Regulation 2, Rule 6, Major Facility Review because it is a major facility as defined by BAAQMD Regulation 2-6-212. It is a major facility because it has the “potential to emit” (as defined by BAAQMD Regulation 2-6-218) more than 100 tons per year of several regulated air pollutants oxides of nitrogen, sulfur dioxide and carbon monoxide. It is also a major facility because it has the potential to emit more than 10 tons per year of hydrogen chloride (HCl), a hazardous air pollutant (HAP) or more than 25 tons per year of combined HAPs (HCl, benzene, zylene, toluene, mercury, etc...).

Major Facility Review permits (Title V permits) must meet specifications contained in 40 CFR, Part 70 as delineated in BAAQMD Regulation 2, Rule 6. The permits must contain all “applicable requirements” (as defined in BAAQMD Regulation 2-6-202), including emission limits and standards, monitoring requirements, recordkeeping requirements, and reporting requirements. The permit holders must submit reports of all required monitoring at least every six months and compliance certifications at least every year.

In the Bay Area, State and District requirements are also “applicable requirements” and are included in the permit. These requirements can be federally enforceable or non-federally enforceable. All applicable requirements are contained in Sections I through VI of the permit.

Each facility in the Bay Area is assigned a facility identifier that consists of a letter and a 4-digit number. This identifier is also considered to be the identifier for the permit. The identifier for this facility is A0017.

This application is for a minor revision to the Title V Permit. The purpose of this revision is to include the operation of two synthetic gypsum feeders (S-223 and S-246). Both synthetic gypsum feeders were installed in 1994, but were not placed in synthetic gypsum services until March of 2010. Lehigh obtained Permit to Operate for S-223 and S-246 in August 2011 under New Source Review (NSR) Application # 23594. The synthetic gypsum is used to partially replace the permitted natural gypsum that Lehigh blends with clinker to produce cement. For detailed information on the two synthetic gypsum feeders, see the NSR Permit Evaluation Report in Attachment C.

### **Title V Minor Revision:**

The applicable requirements contained in the District Permit to Operate for the Synthetic Gypsum Feeders, S-223 and S-246, will be incorporated into the Title V permit as minor revisions. The synthetic gypsum is used to replace some of the natural gypsum that Lehigh uses in the past; therefore, there is no increase in the total gypsum throughput. Each feeder is equipped with Best Available Control Technology (BACT) equipment and will be emitting less than one pound a day. The two new synthetic gypsum feeders are abated by existing dust collectors, A221 and A-243, which have the same outlet grain loadings, operating hours and air flow rates; therefore, there will no emission increase as a result of adding two new feeders. The total annual production of clinker will still be limited to 1,600,000 tons per year.

The applicable requirements for the Synthetic Gypsum Feeders, S-223 and S-246, are federally enforceable and will be incorporated in the Title V permit as minor revisions as defined by BAAQMD Regulation 2-6-215. Minor revisions are defined as revisions that are not administrative amendments or significant permit revisions. The definition of significant permit revisions is shown below:

- 2-6-226 Significant Permit Revision:** Any revision to a federally enforceable condition contained in a major facility review permit that can be defined as follows:
- 226.1 The incorporation of a change considered a major modification under 40 CFR Parts 51 (NSR) or 52 (PSD);
  - 226.2 The incorporation of a change considered a modification under 40 CFR Parts 60 (NSPS), 61 (NESHAPS), or Section 112 of the Clean Air Act (HAP);
  - 226.3 Any significant change or relaxation of any applicable monitoring, reporting or recordkeeping condition;
  - 226.4 The establishment of or change to a permit term or condition allowing a facility to avoid an applicable requirement, including:
    - 4.1 a federally enforceable emission limit assumed in order to avoid classification as a modification under any provision of Title I of the federal Clean Air Act, or
    - 4.2 an alternative hazardous air pollutant emission limit pursuant to Section 112(i)(5) of the Clean Air Act;
  - 226.5 The establishment of or change to a case-by-case determination of any emission limit or other standard;
  - 226.6 The establishment of or change to a facility-specific determination for ambient impacts, visibility analysis, or increment analysis on portable sources; or
  - 226.7 The incorporation of any requirement promulgated by the U. S. EPA under the authority of the Clean Air Act provided that three or more years remain on the permit term.

The revision is not a major modification for NSR or PSD; a modification for NSPS, NESHAPS, or Section 112 of the federal Clean Air Act; a significant change or relaxation of any existing monitoring, recordkeeping, or reporting condition; the establishment or change to a condition to avoid a federally enforceable requirement; a case-by-case determination of a federally enforceable emission limit or standard; a determination of ambient impacts, visibility analysis, or increment analysis on portable sources, or the incorporation of any Clean Air Act requirement. Therefore, the revisions to the Title V permit will not be significant revisions.

The incorporation of the District Permit to Operate into the Title V permit is not a “case-by-case determination of a federally enforceable emission limit or standard” because no such determination is being made in this action. The District Permit to Operate has been issued and BACT was determined in that process. The purpose of this revision to the Title V permit is so the Title V permit includes all applicable requirements.

This statement of basis will include all proposed changes to the permit in strikeout/underline format. This statement of basis addresses only the proposed changes to the permit. Additional issues were addressed in the documents for the revisions listed below.

This facility received its initial Title V permit on November 5, 2003. Although the current permit expired on October 31, 2008, it continues in force until the District takes final action on the permit renewal. The standard sections of the permit have been updated to include new standard language used in all Title V permits. The proposed permit shows all changes to the existing permit in strikeout/underline format.

Since the initial issuance of the permit, the first minor revision pursuant to Application 9687 was issued on May 9, 2006. The second minor revision pursuant to Application 22954 was issued on July 8, 2011

Several District applications have been processed. These are being incorporated into the proposed permit renewal pursuant to Application 17947. The details are in the permit evaluation/statement of basis for that application, which can be found on the District’s website.

## **B. Facility Description**

The Lehigh Southwest Cement (Lehigh) facility produces Portland cement – a fine gray powder that binds sand and aggregate into concrete. Portland cement is the generic term for hydraulic cement (cement that hardens with the addition of water) used in virtually all concrete. Raw materials used in Portland cement manufacturing are comprised of calcium, silica, alumina, and iron. Although cement can be formed from a wide variety of materials, one of the most common combinations is of limestone, clay and sand. At the Lehigh facility, materials containing these minerals are mined in a quarry, ground to a fine powder, and blended in specific proportions needed for the final cement product. The finely ground mixture of raw materials are heated until partially molten (to temperatures of 2550 to 2750°F) in a cement kiln to produce a pellet-shaped, glass-hard material called clinker. The clinker is then ground with gypsum to an extremely fine powder, Portland cement.

The Portland cement manufacturing process at the Lehigh facility consists of mining and handling of raw materials, raw milling and kiln feed preparation, pyroprocessing, coal and petroleum coke preparation, clinker cooling, and finish milling. The principal operations at Lehigh consist of:

- Quarry Operations
- Primary Storage Piles
- Tertiary Crushing/Preblending
- Raw Milling
- Homogenizing
- Pyroprocessing
- Clinker Storage/Finish Milling
- Finish Product Storage and Load Out
- Fuel Preparation
- Concrete Aggregate Products (Rock Plant)

Primary emissions in the manufacturing of Portland cement at the Lehigh facility are combustion emissions, point-type particulate, and fugitive particulate. Plant operations are monitored and controlled by computer. The real-time computer system monitors feed rates and other parameters to optimize combustion control. Combustion emissions are generated in the pyroprocessing operation. Particulate emissions are generated throughout the facility from numerous stationary and mobile operations.

Baghouses are installed to recover product and control dust emissions from the kiln, mills, clinker cooler, fuel mill, belt conveyor transfer points, bulk unloading stations and at numerous other locations at the facility. Water is sprayed on haul roads and uncovered storage piles to control fugitive dust generation. Facility maintenance activities and practices such as watering of road surfaces and enforcement of the speed limits reduce the quantity of fugitives generated on-site and limit their transport off-site.

## **C. Permit Content**

The legal and factual basis for the permit follows. The permit sections are described in the order presented in the permit.

### **I. Standard Conditions**

This section contains administrative requirements and conditions that apply to all facilities.

#### Changes to permit

There are no changes to Section I in this action.

**II. Equipment**

This section of the permit lists all permitted or significant sources. Each source is identified by an S and a number (e.g., S-24).

Permitted sources are those sources that require a BAAQMD operating permit pursuant to BAAQMD Rule 2-1-302.

Significant sources are those sources that have a potential to emit of more than 2 tons per year of a “regulated air pollutant” (as defined in BAAQMD Rule 2-6-222) or 400 pounds per year of a “hazardous air pollutant” (as defined in BAAQMD Rule 2-6-210).

All abatement (control) devices that control permitted or significant sources are listed. Each abatement device having a primary function to reduce emissions is identified by an A and a number (e.g., A-24). If a source is also an abatement device, such as an engine used to control VOC emissions, it will be listed in the abatement device table, but will have an “S” number. An abatement device may also be a source (such as a thermal oxidizer that burns fuel) of secondary emissions. If the primary function of a device is to control emissions, it is considered an abatement (or “A”) device. If the primary function of a device is a non-control function, the device is considered to be a source (or “S”).

The equipment section is considered to be part of the facility description. It contains information that is necessary for applicability determinations, such as fuel types, contents or sizes of tanks, etc. This information is part of the factual basis of the permit.

Each of the permitted sources has previously been issued a permit to operate pursuant to the requirements of BAAQMD Regulation 2, Permits. These permits are issued in accordance with state law and the District’s regulations. The capacities in the permitted sources table are the maximum allowable capacities for each source, pursuant to Standard Condition I.J and Regulation 2-1-403.

Changes to Permit:

- Table II-A; S-223 and S-246 were added for two synthetic gypsum feeders per NSR Application # 23594
- Table II-B; S-223 and S-246 were added to the source(s) controlled column for existing A-221 and A-243 Dust Collectors.

<b>Table II A - Permitted Sources</b>				
Each of the following sources has been issued a permit to operate pursuant to the requirements of BAAQMD Regulation 2, Permits.				
S-#	Description	Make or Type	Model	Capacity
222	6-GM-2 Gypsum Feeder (6WF4)	Thayer	M	5 tons/hour
<u>223</u>	<u>Synthetic Gypsum Feeder (6WF12)</u>	<u>Custom Design</u>		<u>60 tons/hour</u>
245	6-GM-1 Clay Feeder (6-WF-5) Gypsum	<u>Thayer</u>	<u>M</u>	<u>15 tons/hour</u>
<u>246</u>	<u>Synthetic Gypsum Feeder (6WF11)</u>	<u>Custom Design</u>		<u>60 tons</u>

**Table II B – Abatement Devices**

A-#	Description	Source(s) Controlled	Applicable Requirement	Operating Parameters	Limit or Efficiency
221	Dust Collector 6-DC-6	S-221 <u>and</u> S-223	BAAQMD 6-1-301	Pressure drop & Visible Inspection	Ringelmann 1 for ≤ 3 min/hr
			BAAQMD 6-1-310	Pressure drop & Visible Inspection	0.15 gr/dscf
			BAAQMD 6-1-311, <u>BAAQMD</u> <u>Condition # 24621, Part 2</u>	Source Test every 5 yr	4.10P <sup>0.67</sup> lb/hr where P is process weight, ton/hr
			BAAQMD condition # 4996, part 4	Pressure drop & Visible Inspection	0.0013 gr/dscf
243	Dust Collector 6-DC-9	S-243 <u>and</u> S-246	BAAQMD 6-1-301, BAAQMD condition # 4995, part 1	Pressure drop & Visible Inspection	Ringelmann 1 for ≤ 3 min/hr
			BAAQMD 6-1-310	Pressure drop & Visible Inspection	0.15 gr/dscf
			BAAQMD 6-1-311, <u>BAAQMD</u> <u>Condition # 24621, part 2</u>	Source Test every 5 yr	4.10P <sup>0.67</sup> lb/hr where P is process weight, ton/hr
			BAAQMD condition # 4995, part 3	Pressure drop & Visible Inspection	0.0013 gr/dscf

**III. Generally Applicable Requirements**

This section of the permit lists requirements that generally apply to all sources at a facility including insignificant sources and portable equipment that may not require a District permit. If a generally applicable requirement applies specifically to a source that is permitted or significant, the standard will also appear in Section IV and the monitoring for that requirement will appear in Sections IV and VII of the permit. Parts of this section apply to all facilities (e.g., particulate, architectural coating, odorous substance, and sandblasting standards). In addition, standards that apply to insignificant or unpermitted sources at a facility (e.g., refrigeration units that use more than 50 pounds of an ozone-depleting compound) are placed in this section.

Unpermitted sources are exempt from normal District permits pursuant to an exemption in BAAQMD Regulation 2, Rule 1. They may, however, be specifically described in a Title V permit if they are considered “significant sources” as defined in BAAQMD Rule 2-6-239.

Changes to permit:

There are no changes to Section III in this action.

**IV. Source-Specific Applicable Requirements, Applicable Limits & Compliance Monitoring Requirements**

This section of the permit lists the applicable requirements that apply to permitted or significant sources. These applicable requirements are contained in tables that pertain to one or more sources that have the same requirements. The order of the requirements is:

- District Rules
- SIP Rules (if any) are listed following the corresponding District rules. SIP rules are District rules that have been approved by EPA for inclusion in the California State Implementation Plan. SIP rules are “federally enforceable” and a “Y” (yes) indication will appear in the “Federally Enforceable” column. If the SIP rule is the current District rule, separate citation of the SIP rule is not necessary and the “Federally Enforceable” column will have a “Y” for “yes”. If the SIP rule is not the current District rule, the SIP rule or the necessary portion of the SIP rule is cited separately after the District rule. The SIP portion will be federally enforceable; the non-SIP version will not be federally enforceable, unless EPA has approved it through another program.
- Other District requirements, such as the Manual of Procedures, as appropriate.
- Federal requirements (other than SIP provisions)
- BAAQMD permit conditions. The text of BAAQMD permit conditions is found in Section VI of the permit.
- Federal permit conditions. The text of Federal permit conditions, if any, is found in Section VI of the permit.

Section IV of the permit contains citations to all of the applicable requirements. The text of the requirements is found in the regulations, which are readily available on the District or EPA websites, or in the permit conditions, which are found in Section VI of the permit. All monitoring requirements are cited in Section IV.

Previous Section VII: Applicable Limits and Compliance Monitoring Requirements section of the permit has been deleted and combined with Section IV in this Title V permit.

Section IV and Section VII have been combined in this permit. A discussion of monitoring is included in Section VII of this permit evaluation/statement of basis.

### ***Complex applicability determinations in this Title V Permit Renewal***

#### ***Applicability of 40 CFR, Part 64, Compliance Assurance Monitoring (CAM)***

The Compliance Assurance Monitoring (CAM) regulation in 40 CFR, Part 64 was developed to provide assurance that facilities comply with applicable emissions limitations by adequately monitoring control devices. The CAM rule became effective on November 21, 1997. However, most facilities are not affected by CAM requirements until they submit applications for Title V permit renewal. As required, Lehigh has conducted an applicability analysis for CAM as part of this application. The applicable requirements have been incorporated in Table III-General.

CAM applies to a source of criteria pollutant or hazardous air pollutant (HAP) emissions if all the following requirements are met:

- The source is located at a major source for which a Title V permit is required; and
- The source is subject to a federally enforceable emission limitation or standard for a criteria pollutant or HAP; and
- The source uses a control device to comply with the federally enforceable emission limitation or standard; and
- The source has potential pre-control emissions of the regulated pollutant that are equal to or greater than the major source threshold for the pollutant (in BAAQMD, the major source



thresholds are 100 tons per year for each criteria pollutant, 10 tons per year for a single HAP, and 25 tons per year for two or more HAPs); and

- The source is not otherwise exempt from CAM.

The applicability of 40 CFR, Part 64, Compliance Assurance Monitoring, was reviewed for the sources at this facility. The detailed Potential to Emit (PTE) Calculations (Attachment 1) and CAM analysis (Attachment 2) are in Appendix D.

- Sources S-223 and S-246 are not subject to CAM because they have potential pre-control device emissions that are equal or less than 100 tons per year of particulate matter per Section 64.2(a)(3).

Changes to permit:

- Table IV and Table VII have been combined.
- The description of Section VII has been added to Section IV Source-Specific Applicable Requirements, Emission Limits & Compliance Monitoring Requirements. For periodic monitoring, the frequency of the monitoring has also been shown, either annual (A), quarterly (Q), monthly (M), weekly (W), daily (D), or on an event basis (E). No monitoring (N) has been required if the current applicable rule or regulation does not require monitoring, and the operation is unlikely to deviate from the applicable emission limit based upon the nature of the operation.
- A column for Recordkeeping Protocol, R, has been added to Table IV & Table VII for completeness.
- BAAQMD Regulation 6-1-301 and limit has been corrected to say “for < 3 min/hr.”
- The “type of limit” has been changed to “Opacity” for BAAQMD Regulation 6-1-301, since it is an opacity standard.
- The “type of limit” has been changed to “Filterable Particulate” for BAAQMD Regulation 6-1-310 and 6-1-311, since it is a filterable particulate standard.
- Visible inspection by Method 9 or Method 22 are visible emission observations.

Table IV & Table VII – AA and X  
S-221, S-222, S-223, S-240, S-243, S-244, S-245 and S-246

- Existing BAAQMD Condition # 4995, # 4996 and # 24621 were assigned to S-223 and S-246 and added per NSR Application # 23594.

<b>Table IV &amp; Table VII- AA</b> <b>Source-specific Applicable Requirements, Applicable Limits &amp; Compliance Monitoring Requirements</b> <b>S-222 Gypsum feeder (6-WF-4) abated by A-222 Dust Collector,</b> <b><u>S-223 Synthetic Gypsum Feeder (6-WF-12) abated by A-221 Dust Collector,</u></b> <b>S-240 Additive Conveyor/bins abated by A-240 Dust Collector,</b> <b>S-243 6-GM-1 Gypsum Feeder (6-WF-9) abated by A-243 Dust Collector,</b> <b>S-244 Pozzolan Feeder (6-WF-7) abated by A-244 Dust Collector,</b> <b>S-245 6-GM-1 Clay Feeder (6-WF-5) abated by A-245 Dust Collector,</b> <b><u>S-246 Synthetic Gypsum Feeder (6-WF-11) abated by A-243 Dust Collector</u></b>							
Applicable Requirement	Regulation Title or Description of Requirement	Limit	Monitoring Citation	Monitoring & Frequency	Reporting	R	FE
<b>BAAQMD Regulation</b>	<b>Particulate Matter (12/05/07)</b>						

**Table IV & Table VII- AA**  
**Source-specific Applicable Requirements, Applicable Limits & Compliance Monitoring Requirements**  
**S-222 Gypsum feeder (6-WF-4) abated by A-222 Dust Collector,**  
**S-223 Synthetic Gypsum Feeder (6-WF-12) abated by A-221 Dust Collector,**  
**S-240 Additive Conveyor/bins abated by A-240 Dust Collector,**  
**S-243 6-GM-1 Gypsum Feeder (6-WF-9) abated by A-243 Dust Collector,**  
**S-244 Pozzolan Feeder (6-WF-7) abated by A-244 Dust Collector,**  
**S-245 6-GM-1 Clay Feeder (6-WF-5) abated by A-245 Dust Collector,**  
**S-246 Synthetic Gypsum Feeder (6-WF-11) abated by A-243 Dust Collector**

Applicable Requirement	Regulation Title or Description of Requirement	Limit	Monitoring Citation	Monitoring & Frequency	Reporting	R	FE
<b>n 6, Rule 1</b>							
6-1-301	Ringelmann Number 1 Limitation	OPACITY Ringelmann 1.0 for < 3 min/hr	BAAQMD condition # 4995, part 2 BAAQMD condition # 20751, part 3b	Pressure Drop Monitoring  P/Q	Once every six months	Y	N
6-1-301	Ringelmann Number 1 Limitation	OPACITY Ringelmann 1.0 for < 3 min/hr	BAAQMD condition # 20753, part 1	Visual Inspection (M22)  P/Q	Once every six months	Y	N
6-1-305	Visible Particles						N
6-1-310	Particulate Weight Limitation	FILTERABLE PARTICULATE 0.15 gr/dscf	BAAQMD condition # 4995, part 2 BAAQMD condition # 20751, part 3b	Pressure Drop Monitoring  P/Q	Once every six months	Y	N
6-1-311	General Operations	FILTERABLE PARTICULATE 4.10P <sup>0.67</sup> lb/hr where P is process weight, ton/hr	<u>BAAQMD condition # 24621, part 2</u>	Source Test P/once every 5 yrs	Once every 5 yrs	Y	N
6-1-401	Appearance of Emissions						N
6-1-601	Particulate Matter, Sampling, Sampling Facilities, Opacity Instruments and Appraisal of Visible Emissions						N
<b>SIP Regulation 6</b>	<b>Particulate Matter and Visible Emissions (09/04/98)</b>						
6-301	Ringelmann Number 1 Limitation	OPACITY Ringelmann 1.0 for < 3 min/hr	BAAQMD condition # 4995, part 2 BAAQMD condition # 20751, part 3b	Pressure Drop Monitoring  P/Q	Once every six months	Y	Y

**Table IV & Table VII- AA**  
**Source-specific Applicable Requirements, Applicable Limits &**  
**Compliance Monitoring Requirements**  
**S-222 Gypsum feeder (6-WF-4) abated by A-222 Dust Collector,**  
**S-223 Synthetic Gypsum Feeder (6-WF-12) abated by A-221 Dust Collector,**  
**S-240 Additive Conveyor/bins abated by A-240 Dust Collector,**  
**S-243 6-GM-1 Gypsum Feeder (6-WF-9) abated by A-243 Dust Collector,**  
**S-244 Pozzolan Feeder (6-WF-7) abated by A-244 Dust Collector,**  
**S-245 6-GM-1 Clay Feeder (6-WF-5) abated by A-245 Dust Collector,**  
**S-246 Synthetic Gypsum Feeder (6-WF-11) abated by A-243 Dust Collector**

Applicable Requirement	Regulation Title or Description of Requirement	Limit	Monitoring Citation	Monitoring & Frequency	Reporting	R	FE
6-301	Ringelmann Number 1 Limitation	OPACITY Ringelmann 1.0 for < 3 min/hr	BAAQMD condition # 20753, part 1	Visual Inspection (M22)  P/Q	Once every six months	Y	Y
6-305	Visible Particles						Y
6-310	Particulate Weight Limitation	FILTERABLE PARTICULATE 0.15 gr/dscf	BAAQMD condition # 4995, part 2 BAAQMD condition # 20751, part 3b	Pressure Drop Monitoring  P/Q	Once every six months	Y	Y
6-311	General Operations	FILTERABLE PARTICULATE 4.10P <sup>0.67</sup> lb/hr where P is process weight, ton/hr	<u>BAAQMD condition # 24621, part 2</u>	Source Test P/once every 5 yrs	Once every 5 yrs	Y	Y
6-401	Appearance of Emissions						Y
6-601	Particulate Matter, Sampling, Sampling Facilities, Opacity Instruments and Appraisal of Visible Emissions						Y
<b>NESHAP, 40 CFR, Part 63 Subpart A</b>	<b>General Provisions (4/20/06)</b>						
63.1	Applicability						Y
63.2	Definitions						Y
63.3	Units and Abbreviations						Y
63.4	Prohibited Activities and Circumvention						Y
63.5	Preconstruction review and notification requirements						Y
63.6	Compliance with Standards and Maintenance Requirements						Y
63.7	Performance Testing Requirements						Y
63.8	Monitoring Requirements						Y

**Table IV & Table VII- AA**  
**Source-specific Applicable Requirements, Applicable Limits & Compliance Monitoring Requirements**  
**S-222 Gypsum feeder (6-WF-4) abated by A-222 Dust Collector,**  
**S-223 Synthetic Gypsum Feeder (6-WF-12) abated by A-221 Dust Collector,**  
**S-240 Additive Conveyor/bins abated by A-240 Dust Collector,**  
**S-243 6-GM-1 Gypsum Feeder (6-WF-9) abated by A-243 Dust Collector,**  
**S-244 Pozzolan Feeder (6-WF-7) abated by A-244 Dust Collector,**  
**S-245 6-GM-1 Clay Feeder (6-WF-5) abated by A-245 Dust Collector,**  
**S-246 Synthetic Gypsum Feeder (6-WF-11) abated by A-243 Dust Collector**

Applicable Requirement	Regulation Title or Description of Requirement	Limit	Monitoring Citation	Monitoring & Frequency	Reporting	R	FE
63.9	Notification Requirements						Y
63.10	Recordkeeping and Reporting Requirements						Y
63.12	State Authority and Delegation						Y
<b>NESHAP, 40 CFR, Part 63 Subpart LLL</b>	<b>Portland Cement Manufacturing Industry (9/9/10)</b>						
63.1340(b)(7)	Applicability						Y
63.1341	Definitions						Y
63.1342	Standards: General						Y
63.1345	Opacity Limit	OPACITY 10%	63.1349(b)(2) 63.1350(f)(1)	M9 Initial M22 P/M			Y
63.1347	Operation & Maintenance Plan Requirements					Y	Y
63.1347(a)(1)	Procedures for Proper O&M of Affected Source and Air Pollution Control Devices						Y
63.1348(a)(2)	Initial Compliance Requirements	Opacity 10%	63.1349(b)(2)	M9 Initial			Y
63.1348(b)(3)(i)	Continuous Compliance Requirements	Opacity 10%	63.1350(f)(1)	M22 P/M			Y
63.1348(c)	Changes in Operations						Y
63.1348(d)	General Duty to Minimize Emissions						Y
63.1349(a)	Performance test reports	Test description, method, etc...			Y		Y
63.1349(b)(2)	Opacity Performance Testing Requirements	Opacity M9 of appendix A-4, Part 60 (3 hours – 30 6 mins ave)		M9 Initial		Y	Y
63.1349(b)(2)(i)	Opacity Performance Testing Requirements	If no individual opacity >10%, M9 can reduce to 1 hr	63.1349(c)	M9 Initial		Y	Y
63.1349(b)(2)	Opacity Performance Testing	If no more than 3 reading of	63.1349(c)	M9		Y	Y

**Table IV & Table VII- AA**  
**Source-specific Applicable Requirements, Applicable Limits & Compliance Monitoring Requirements**  
**S-222 Gypsum feeder (6-WF-4) abated by A-222 Dust Collector,**  
**S-223 Synthetic Gypsum Feeder (6-WF-12) abated by A-221 Dust Collector,**  
**S-240 Additive Conveyor/bins abated by A-240 Dust Collector,**  
**S-243 6-GM-1 Gypsum Feeder (6-WF-9) abated by A-243 Dust Collector,**  
**S-244 Pozzolan Feeder (6-WF-7) abated by A-244 Dust Collector,**  
**S-245 6-GM-1 Clay Feeder (6-WF-5) abated by A-245 Dust Collector,**  
**S-246 Synthetic Gypsum Feeder (6-WF-11) abated by A-243 Dust Collector**

Applicable Requirement	Regulation Title or Description of Requirement	Limit	Monitoring Citation	Monitoring & Frequency	Reporting	R	FE
(ii)	Requirements	10% for the first-hour period, M9 can reduce to 1 hr		Initial			
63.1349(d)	Performance Test Reporting Requirement	Within 60 days after the initial performance test			Initial	Y	Y
63.1349(e)	Performance Test Conducted Under Representative Performance					Y	Y
63.1350(a)	Monitoring Requirements	Startup & shutdown averaged separately from normal operation					Y
63.1350(f)(1)(i)	Opacity Monitor Requirement	10-min visible test with M22 of appendix A-7		M22 P/M			Y
63.1350(f)(1)(ii)	Opacity Monitor Requirement	If no visible observed in 6 consecutive tests, reduce M22 to semi-annual		M22 P/SA			Y
63.1350(f)(1)(iii)	Opacity Monitor Requirement	If no visible observed during the semi-annual test, reduce M22 to annual		M22 P/A			Y
63.1350(f)(1)(iv)	Opacity Monitor Requirement	If visible observed during any M22 tests, conduct 5 6-mins of M9 within 1 hour		M22, then M9 within 1 hr P/E			Y
63.1350(f)(1)(v)	Enclosed Opacity Monitor Requirement	M22 do not apply to enclosed conveying system transfer point					Y
63.1350(f)(1)(vi)	Partially Enclosed or Unenclosed Opacity Monitor Requirement	M22 for at least 10 mins		M22			Y
63.1350(f)(1)(vii)	Building Opacity Monitor Requirement	M22 for at least 10 mins		M22			Y
63.1350(f)(3)	Corrective Actions	Within 1 hour		P/E			Y
63.1350(m)(6)(i)	Specific Pressure Monitoring Requirement	Location of the pressure sensor(s)					Y
63.1350(m)(6)(ii)		Minimize or eliminate pulsating pressure, vibration, and internal & external corrosion					Y
63.1350(m)(6)(iii)		Gauge minimum tolerance of 1.27 centimeters of water or a transducer with a minimum tolerance of 1 % of the pressure range					Y
63.1350(m)(6)(iv)		Check pressure tap pluggage daily		P/D			Y

**Table IV & Table VII- AA**  
**Source-specific Applicable Requirements, Applicable Limits &**  
**Compliance Monitoring Requirements**  
**S-222 Gypsum feeder (6-WF-4) abated by A-222 Dust Collector,**  
**S-223 Synthetic Gypsum Feeder (6-WF-12) abated by A-221 Dust Collector,**  
**S-240 Additive Conveyor/bins abated by A-240 Dust Collector,**  
**S-243 6-GM-1 Gypsum Feeder (6-WF-9) abated by A-243 Dust Collector,**  
**S-244 Pozzolan Feeder (6-WF-7) abated by A-244 Dust Collector,**  
**S-245 6-GM-1 Clay Feeder (6-WF-5) abated by A-245 Dust Collector,**  
**S-246 Synthetic Gypsum Feeder (6-WF-11) abated by A-243 Dust Collector**

Applicable Requirement	Regulation Title or Description of Requirement	Limit	Monitoring Citation	Monitoring & Frequency	Reporting	R	FE
63.1350(m)(6)(v)		Check gauge calibration quarterly and transducer calibration monthly		P/Q and P/M			Y
63.1350(m)(6)(vi)		Conduct calibration checks any time exceedance of the manufacturer's specified maximum pressure range or install a new pressure sensor					Y
63.1350(p)	Development and Submittal of Monitoring Plans						Y
63.1351	Compliance date June 14, 2002						Y
63.1353(a)	Notification Requirements of Subpart A						Y
63.1353(b)(3)	Opacity test notification						Y
63.1353(b)(5)	Notification of Compliance Status						Y
63.1354(a)	Reporting Requirements of Subpart A						Y
63.1354(b)(2)	Opacity observation reporting						Y
63.1354(b)(4)	Semiannual reporting of O&M and SSM actions consistent with the plans	If action during startup, shutdown, or malfunction is consistent with procedures			Once every six months	Y	Y
63.1354(b)(5)	Notification of actions not consistent with O&M and SSM plans	If action during startup, shutdown, or malfunction is NOT consistent with procedures			Within 2 working days	Y	Y
63.1354(c)	Semiannual Report	Report must include malfunction			Once every six months	Y	Y
63.1355	Recordkeeping Requirements						Y
63.1356	Source with Multiple Emission Limits or Monitoring Requirements	Affected facility must comply with most stringent emission limit					Y
63.1358	Implementation and Enforcement						Y
<b>BAAQMD Condition # 4995</b>							
Part 1	Visible Particulates requirement (Basis: Regulation 1-301,	OPACITY Ringelmann 1.0 < 3 min/hr	BAAQMD condition #	Pressure Drop	Once every six months	Y	Y

**Table IV & Table VII- AA**  
**Source-specific Applicable Requirements, Applicable Limits &**  
**Compliance Monitoring Requirements**  
**S-222 Gypsum feeder (6-WF-4) abated by A-222 Dust Collector,**  
**S-223 Synthetic Gypsum Feeder (6-WF-12) abated by A-221 Dust Collector,**  
**S-240 Additive Conveyor/bins abated by A-240 Dust Collector,**  
**S-243 6-GM-1 Gypsum Feeder (6-WF-9) abated by A-243 Dust Collector,**  
**S-244 Pozzolan Feeder (6-WF-7) abated by A-244 Dust Collector,**  
**S-245 6-GM-1 Clay Feeder (6-WF-5) abated by A-245 Dust Collector,**  
**S-246 Synthetic Gypsum Feeder (6-WF-11) abated by A-243 Dust Collector**

Applicable Requirement	Regulation Title or Description of Requirement	Limit	Monitoring Citation	Monitoring & Frequency	Reporting	R	FE
	Regulation 6-1-301, BACT)		4995, part 2 BAAQMD condition # 20751, part 3b	Monitoring  P/Q			
Part 2	Abatement requirement (Basis: Regulation 2-2-212 Cumulative Increase)						Y
Part 3	Outlet grain loading (Basis: Regulation 2-2-301.1 BACT)	PM10 0.0013 gr/dscf	BAAQMD condition # 4995, part 2 BAAQMD condition # <del>20751</del> 24621, part <del>3b</del> 2	<del>Pressure Drop Monitoring</del> Source test  P/Every 5 yrs	Once every <del>six months</del> 5 yrs	Y	Y
Part 6	Record keeping requirement (Basis: Cumulative Increase)						Y
Part 7	<u>Combined natural and synthetic gypsum throughput for S-222, S-223, S-243 and S-246</u>	<u>84,210 tons in any consecutive 12-month period</u>	<u>BAAQMD condition # 4995, part 6</u>			Y	Y
Part 8	<u>Synthetic gypsum throughput for S-222, S-223, S-243 and S-246</u>	<u>15,000 tons in any consecutive 12-month period</u>	<u>BAAQMD condition # 4995, part 6</u>			Y	Y
<b>BAAQMD Condition #20751</b>							
Part 1	Baghouse Monitoring Requirement (Regulation 2-6-503)						Y
Part 2	Baghouse Pressure Drop Limit (Regulation 2-6-503)	Operating pressure drop range (0 to 10 inch water)	BAAQMD condition # 20751, part 3b	Pressure Drop Monitoring  P/Q	Once every six months	Y	Y
Part 3b	Baghouse Quarterly Pressure Drop Recording requirement (Regulation 2-6-503)						Y
Part 4	Reporting Pressure Drop Exceedances (Regulation 2-6-501, BAAQMD MOP Volume II, Part 3, §4.7)						Y
Part 5	Annual Inspection (Regulation 2-6-503)						Y
Part 6	Recordkeeping (Regulation 2-6-						Y

**Table IV & Table VII- AA**  
**Source-specific Applicable Requirements, Applicable Limits & Compliance Monitoring Requirements**  
**S-222 Gypsum feeder (6-WF-4) abated by A-222 Dust Collector,**  
**S-223 Synthetic Gypsum Feeder (6-WF-12) abated by A-221 Dust Collector,**  
**S-240 Additive Conveyor/bins abated by A-240 Dust Collector,**  
**S-243 6-GM-1 Gypsum Feeder (6-WF-9) abated by A-243 Dust Collector,**  
**S-244 Pozzolan Feeder (6-WF-7) abated by A-244 Dust Collector,**  
**S-245 6-GM-1 Clay Feeder (6-WF-5) abated by A-245 Dust Collector,**  
**S-246 Synthetic Gypsum Feeder (6-WF-11) abated by A-243 Dust Collector**

Applicable Requirement	Regulation Title or Description of Requirement	Limit	Monitoring Citation	Monitoring & Frequency	Reporting	R	FE
	501)						
<b>BAAQMD Condition #20753</b>							
Part 1	Quarterly EPA Method 22 Visible Emission Monitoring for A-11 through A-15 (Regulation 2-6-503)						Y
Part 3	Recordkeeping (Regulation 2-6-501)						Y
<b>BAAQMD Condition # 24621</b>							
Part 2	Perform Source Test at least once every five years (Regulation 6-1)	OPACITY Ringelmann 1.0 for < 3 min/hr  FILTERABLE PARTICULATE 0.15 gr/dscf & 4.10P <sup>0.67</sup> lb/hr where P is process weight		Source Test  P/once every 5 yrs	Once every 5 yrs	Y	Y

**Table IV & Table VII- X**  
**Source-specific Applicable Requirements, Applicable Limits & Compliance Monitoring Requirements**  
**S-216 Clinker Cake Conveyor (6-BC-13) abated by A-216 Dust Collector,**  
**S-217 Clinker Cake Conveyor (6-BC-15) abated by A-217 Dust Collector,**  
**S-221 Clinker Cake Feeder (6-WF-2) abated by A-221 Dust Collector,**  
**S-223 Synthetic Gypsum Feeder (6WF-12) abated by A-221 Dust Collector,**  
**S-231 Pressed Cake Bin (6-SS-2) abated by A-231 Dust Collector ,**  
**S-242 Clinker Cake Feeder (6-WF-3) abated by A-242 Dust Collector**

Applicable Requirement	Regulation Title or Description of Requirement	Limit	Monitoring Citation	Monitoring & Frequency	Reporting	R	FE
<b>BAAQMD</b>	<b>Monitoring</b>	Hours of Operation	BAAQMD condition # 4996, part 5	Record keeping	Once every six months	Y	Y



<b>Table IV &amp; Table VII- X</b> <b>Source-specific Applicable Requirements, Applicable Limits &amp;</b> <b>Compliance Monitoring Requirements</b> <b>S-216 Clinker Cake Conveyor (6-BC-13) abated by A-216 Dust Collector,</b> <b>S-217 Clinker Cake Conveyor (6-BC-15) abated by A-217 Dust Collector,</b> <b>S-221 Clinker Cake Feeder (6-WF-2) abated by A-221 Dust Collector,</b> <u><b>S-223 Synthetic Gypsum Feeder (6WF-12) abated by A-221 Dust Collector,</b></u> <b>S-231 Pressed Cake Bin (6-SS-2) abated by A-231 Dust Collector ,</b> <b>S-242 Clinker Cake Feeder (6-WF-3) abated by A-242 Dust Collector</b>							
Applicable Requirement	Regulation Title or Description of Requirement	Limit	Monitoring Citation	Monitoring & Frequency	Reporting	R	FE
<b>Regulation 2-6-503</b>				P/D			
<b>BAAQMD Regulation 6, Rule 1</b>	<b>Particulate Matter (12/05/07)</b>						
6-1-301	Ringelmann Number 1 Limitation	OPACITY Ringelmann 1.0 for < 3 min/hr	BAAQMD condition # 4996, part 2	Pressure Drop Monitoring  P/Q	Once every six months	Y	N
6-1-305	Visible Particles						N
6-1-310	Particulate Weight Limitation	FILTERABLE PARTICULATE 0.15 gr/dscf	BAAQMD condition # 4996, part 2 BAAQMD condition # 20751, part 3b	Pressure Drop Monitoring  P/Q	Once every six months	Y	N
6-1-311	General Operations	FILTERABLE PARTICULATE 4.10P <sup>0.67</sup> lb/hr where P is process weight, ton/hr		Source Test  P/once every 5 yrs	Once every 5 yrs	Y	N
6-1-401	Appearance of Emissions						N
6-1-601	Particulate Matter, Sampling, Sampling Facilities, Opacity Instruments and Appraisal of Visible Emissions						N
<b>SIP Regulation 6</b>	<b>Particulate Matter and Visible Emissions (09/04/98)</b>						
6-301	Ringelmann Number 1 Limitation	OPACITY Ringelmann 1.0 for < 3 min/hr	BAAQMD condition # 4996, part 2	Pressure Drop Monitoring  P/Q	Once every six months	Y	Y
6-305	Visible Particles						Y

**Table IV & Table VII- X**  
**Source-specific Applicable Requirements, Applicable Limits &**  
**Compliance Monitoring Requirements**

**S-216 Clinker Cake Conveyor (6-BC-13) abated by A-216 Dust Collector,**  
**S-217 Clinker Cake Conveyor (6-BC-15) abated by A-217 Dust Collector,**  
**S-221 Clinker Cake Feeder (6-WF-2) abated by A-221 Dust Collector,**  
**S-223 Synthetic Gypsum Feeder (6WF-12) abated by A-221 Dust Collector,**  
**S-231 Pressed Cake Bin (6-SS-2) abated by A-231 Dust Collector ,**  
**S-242 Clinker Cake Feeder (6-WF-3) abated by A-242 Dust Collector**

Applicable Requirement	Regulation Title or Description of Requirement	Limit	Monitoring Citation	Monitoring & Frequency	Reporting	R	FE
6-310	Particulate Weight Limitation	FILTERABLE PARTICULATE 0.15 gr/dscf	BAAQMD condition # 4996, part 2 BAAQMD condition # 20751, part 3b	Pressure Drop Monitoring  P/Q	Once every six months	Y	Y
6-311	General Operations	FILTERABLE PARTICULATE 4.10P <sup>0.67</sup> lb/hr where P is process weight, ton/hr		Source Test  P/once every 5 yrs	Once every 5 yrs	<u>Y</u>	Y
6-401	Appearance of Emissions						Y
6-601	Particulate Matter, Sampling, Sampling Facilities, Opacity Instruments and Appraisal of Visible Emissions						Y
<b>NESHAP, 40 CFR, Part 63 Subpart A</b>	<b>General Provisions (4/20/06)</b>						
63.1	Applicability						Y
63.2	Definitions						Y
63.3	Units and Abbreviations						Y
63.4	Prohibited Activities and Circumvention						Y
63.5	Preconstruction review and notification requirements						Y
63.6	Compliance with Standards and Maintenance Requirements						Y
63.7	Performance Testing Requirements						Y
63.8	Monitoring Requirements						Y
63.9	Notification Requirements						Y
63.10	Recordkeeping and Reporting Requirements						Y
63.12	State Authority and Delegation						Y

**Table IV & Table VII- X**  
**Source-specific Applicable Requirements, Applicable Limits &**  
**Compliance Monitoring Requirements**

**S-216 Clinker Cake Conveyor (6-BC-13) abated by A-216 Dust Collector,**  
**S-217 Clinker Cake Conveyor (6-BC-15) abated by A-217 Dust Collector,**  
**S-221 Clinker Cake Feeder (6-WF-2) abated by A-221 Dust Collector,**  
**S-223 Synthetic Gypsum Feeder (6WF-12) abated by A-221 Dust Collector,**  
**S-231 Pressed Cake Bin (6-SS-2) abated by A-231 Dust Collector ,**  
**S-242 Clinker Cake Feeder (6-WF-3) abated by A-242 Dust Collector**

Applicable Requirement	Regulation Title or Description of Requirement	Limit	Monitoring Citation	Monitoring & Frequency	Reporting	R	FE
<b>NESHAP , 40 CFR, Part 63 Subpart LLL</b>	<b>Portland Cement Manufacturing Industry (9/9/10) (Effective on 11/8/10)</b>						
63.1340(b)(7)	Applicability						Y
63.1341	Definitions						Y
63.1342	Standards: General						Y
63.1345	Opacity Limit	OPACITY 10%	63.1349(b)(2) 63.1350(f)(1)	M9 Initial M22 P/M			Y
63.1347	Operation & Maintenance Plan Requirements					Y	Y
63.1347(a)(1)	Procedures for Proper O&M of Affected Source and Air Pollution Control Devices						Y
63.1348(a)(2)	Initial Compliance Requirements	Opacity 10%	63.1349(b)(2)	M9 Initial			Y
63.1348(b)(3)(i)	Continuous Compliance Requirements	Opacity 10%	63.1350(f)(1)	M22 P/M			Y
63.1348(c)	Changes in Operations						Y
63.1348(d)	General Duty to Minimize Emissions						Y
63.1349(a)	Performance test reports	Test description, method, etc...			Y		Y
63.1349(b)(2)	Opacity Performance Testing Requirements	Opacity M9 of appendix A-4, Part 60 (3 hours – 30 6 mins ave)		M9 Initial		Y	Y
63.1349(b)(2)(i)	Opacity Performance Testing Requirements	If no individual opacity >10%, M9 can reduce to 1 hr	63.1349(c)	M9 Initial		Y	Y
63.1349(b)(2)(ii)	Opacity Performance Testing Requirements	If no more than 3 reading of 10% for the first-hour period, M9 can reduce to 1 hr	63.1349(c)	M9 Initial		Y	Y
63.1349(d)	Performance Test Reporting Requirement	Within 60 days after the initial performance test			Initial	Y	Y

**Table IV & Table VII- X**  
**Source-specific Applicable Requirements, Applicable Limits &  
 Compliance Monitoring Requirements**

**S-216 Clinker Cake Conveyor (6-BC-13) abated by A-216 Dust Collector,  
 S-217 Clinker Cake Conveyor (6-BC-15) abated by A-217 Dust Collector,  
 S-221 Clinker Cake Feeder (6-WF-2) abated by A-221 Dust Collector,  
S-223 Synthetic Gypsum Feeder (6WF-12) abated by A-221 Dust Collector,  
 S-231 Pressed Cake Bin (6-SS-2) abated by A-231 Dust Collector ,  
 S-242 Clinker Cake Feeder (6-WF-3) abated by A-242 Dust Collector**

Applicable Requirement	Regulation Title or Description of Requirement	Limit	Monitoring Citation	Monitoring & Frequency	Reporting	R	FE
63.1349(e)	Performance Test Conducted Under Representative Performance					Y	Y
63.1350(a)	Monitoring Requirements	Startup & shutdown averaged separately from normal operation					Y
63.1350(f)(1)(i)	Opacity Monitor Requirement	10-min visible test with M22 of appendix A-7		M22 P/M			Y
63.1350(f)(1)(ii)	Opacity Monitor Requirement	If no visible observed in 6 consecutive tests, reduce M22 to semi-annual		M22 P/SA			Y
63.1350(f)(1)(iii)	Opacity Monitor Requirement	If no visible observed during the semi-annual test, reduce M22 to annual		M22 P/A			Y
63.1350(f)(1)(iv)	Opacity Monitor Requirement	If visible observed during any M22 tests, conduct 5 6-mins of M9 within 1 hour		M22, then M9 within 1 hr P/E			Y
63.1350(f)(1)(v)	Enclosed Opacity Monitor Requirement	M22 do not apply to enclosed conveying system transfer point					Y
63.1350(f)(1)(vi)	Partially Enclosed or Unenclosed Opacity Monitor Requirement	M22 for at least 10 mins		M22			Y
63.1350(f)(1)(vii)	Building Opacity Monitor Requirement	M22 for at least 10 mins		M22			Y
63.1350(f)(3)	Corrective Actions	Within 1 hour		P/E			Y
63.1350(m)(6)(i)	Specific Pressure Monitoring Requirement	Location of the pressure sensor(s)					Y
63.1350(m)(6)(ii)		Minimize or eliminate pulsating pressure, vibration, and internal & external corrosion					Y
63.1350(m)(6)(iii)		Gauge minimum tolerance of 1.27 centimeters of water or a transducer with a minimum tolerance of 1 % of the pressure range					Y
63.1350(m)(6)(iv)		Check pressure tap pluggage daily		P/D			Y
63.1350(m)(6)(v)		Check gauge calibration quarterly and transducer		P/Q and P/M			Y

**Table IV & Table VII- X**  
**Source-specific Applicable Requirements, Applicable Limits &**  
**Compliance Monitoring Requirements**

**S-216 Clinker Cake Conveyor (6-BC-13) abated by A-216 Dust Collector,**  
**S-217 Clinker Cake Conveyor (6-BC-15) abated by A-217 Dust Collector,**  
**S-221 Clinker Cake Feeder (6-WF-2) abated by A-221 Dust Collector,**  
**S-223 Synthetic Gypsum Feeder (6WF-12) abated by A-221 Dust Collector,**  
**S-231 Pressed Cake Bin (6-SS-2) abated by A-231 Dust Collector ,**  
**S-242 Clinker Cake Feeder (6-WF-3) abated by A-242 Dust Collector**

Applicable Requirement	Regulation Title or Description of Requirement	Limit	Monitoring Citation	Monitoring & Frequency	Reporting	R	FE
		calibration monthly					
63.1350(m)(6)(vi)		Conduct calibration checks any time exceedance of the manufacturer's specified maximum pressure range or install a new pressure sensor					Y
63.1350(p)	Development and Submittal of Monitoring Plans						Y
63.1351	Compliance date June 14, 2002						Y
63.1353(a)	Notification Requirements of Subpart A						Y
63.1353(b)(3)	Opacity test notification						Y
63.1353(b)(5)	Notification of Compliance Status						Y
63.1354(a)	Reporting Requirements of Subpart A						Y
63.1354(b)(2)	Opacity observation reporting						Y
63.1354(b)(4)	Semiannual reporting of O&M and SSM actions consistent with the plans	If action during startup, shutdown, or malfunction is consistent with procedures			Once every six months	Y	Y
63.1354(b)(5)	Notification of actions not consistent with O&M and SSM plans	If action during startup, shutdown, or malfunction is NOT consistent with procedures			Within 2 working days	Y	Y
63.1354(c)	Semiannual Report	Report must include malfunction			Once every six months	Y	Y
63.1355	Recordkeeping Requirements						Y
63.1356	Source with Multiple Emission Limits or Monitoring Requirements	Affected facility must comply with most stringent emission limit					Y
63.1358	Implementation and Enforcement						Y
<b><u>BAAQM</u></b> <b><u>D</u></b> <b><u>Condition # 4995</u></b>							
Part 7	<u>Combined natural and synthetic gypsum throughput for S-222, S-223, S-243 and S-246</u>	<u>84,210 tons in any consecutive 12-month period</u>	<u>BAAQMD condition # 4995, part 6</u>			<u>Y</u>	<u>Y</u>
Part 8	<u>Synthetic gypsum throughput for</u>	<u>15,000 tons in any consecutive</u>	<u>BAAQMD</u>			<u>Y</u>	<u>Y</u>

<p align="center"><b>Table IV &amp; Table VII- X</b></p> <p align="center"><b>Source-specific Applicable Requirements, Applicable Limits &amp; Compliance Monitoring Requirements</b></p> <p align="center"><b>S-216 Clinker Cake Conveyor (6-BC-13) abated by A-216 Dust Collector,</b>  <b>S-217 Clinker Cake Conveyor (6-BC-15) abated by A-217 Dust Collector,</b>  <b>S-221 Clinker Cake Feeder (6-WF-2) abated by A-221 Dust Collector,</b>  <u><b>S-223 Synthetic Gypsum Feeder (6WF-12) abated by A-221 Dust Collector,</b></u>  <b>S-231 Pressed Cake Bin (6-SS-2) abated by A-231 Dust Collector ,</b>  <b>S-242 Clinker Cake Feeder (6-WF-3) abated by A-242 Dust Collector</b></p>							
Applicable Requirement	Regulation Title or Description of Requirement	Limit	Monitoring Citation	Monitoring & Frequency	Reporting	R	FE
	<u>S-222, S-223, S-243 and S-246</u>	<u>12-month period</u>	<u>condition # 4995, part 6</u>				
<b>BAAQMD Condition # 4996</b>							
Part 1	Visible Particulates requirement (Basis: Regulation 1-301, BACT)	OPACITY Ringelmann 1.0 for < 3 min/hr	BAAQMD condition # 4996, part 2 BAAQMD condition # 20751, part 3b	Pressure Drop Monitoring  P/Q	Once every six months	Y	Y
Part 2	Abatement requirement (Basis: Regulation 2-2-212 Cumulative Increase)						Y
Part 3	Outlet grain loading for A-217 and A-231 (Basis: Regulation 2-2-301.1 BACT)	PM10 0.006 gr/dscf	<u>BAAQMD condition # 24621, part 2</u> <u>BAAQMD condition # 4996, part 2</u>	<u>Source Test</u>  P/every 5yrs Pressure Drop Monitoring  P/E	<u>Once every 5 yrs</u> <u>Once every six months</u>	Y	Y
Part 4	Outlet grain loading for A-216, A-221 and S-242 (Basis: Regulation 2-2-301.1 BACT)	PM10 0.0013 gr/dscf	<u>BAAQMD condition # 24621, part 2</u> <u>BAAQMD condition # 4996, part 2</u>	<u>Source Test</u>  P/every 5yrs Pressure Drop Monitoring  P/E	<u>Once every 5 yrs</u> <u>Once every six months</u>	Y	Y
Part 5	Startup Source test Requirement (Basis: Regulation 2-1-403)						Y
Part 6	Record keeping requirement (Basis: Cumulative Increase)						Y
<b>BAAQMD Condition # 20751</b>							
Part 1	Baghouse Monitoring Requirement						Y

<b>Table IV &amp; Table VII- X</b> <b>Source-specific Applicable Requirements, Applicable Limits &amp; Compliance Monitoring Requirements</b> <b>S-216 Clinker Cake Conveyor (6-BC-13) abated by A-216 Dust Collector,</b> <b>S-217 Clinker Cake Conveyor (6-BC-15) abated by A-217 Dust Collector,</b> <b>S-221 Clinker Cake Feeder (6-WF-2) abated by A-221 Dust Collector,</b> <b>S-223 Synthetic Gypsum Feeder (6WF-12) abated by A-221 Dust Collector,</b> <b>S-231 Pressed Cake Bin (6-SS-2) abated by A-231 Dust Collector ,</b> <b>S-242 Clinker Cake Feeder (6-WF-3) abated by A-242 Dust Collector</b>							
Applicable Requirement	Regulation Title or Description of Requirement	Limit	Monitoring Citation	Monitoring & Frequency	Reporting	R	FE
	(Regulation 2-6-503)						
Part 2	Baghouse Pressure Drop Limit (Regulation 2-6-503)	Operating pressure drop range (0 to 10 inch water)	BAAQMD condition # 4996, part 2 BAAQMD condition # 20751, part 3b	Pressure Drop Monitoring  P/Q	Once every six months	Y	Y
Part 3b	Baghouse Quarterly Pressure Drop Recording requirement (Regulation 2-6-503)						Y
Part 4	Reporting Pressure Drop Exceedances (Regulation 2-6-501, BAAQMD MOP Volume II, Part 3, §4.7)						Y
Part 5	Annual Inspection (Regulation 2-6-503)						Y
Part 6	Recordkeeping (Regulation 2-6-501)						Y
<b>BAAQMD Condition # 24621</b>							
Part 2	Perform Source Test at least once every five years (Regulation 6-1)	OPACITY Ringelmann 1.0 for < 3 min/hr  FILTERABLE PARTICULATE 0.15 gr/dscf & 4.10P <sup>0.67</sup> lb/hr where P is process weight		Source Test  P/once every 5 yrs	Once every 5 yrs	Y	Y

**V. Schedule of Compliance**

A schedule of compliance is required in all Title V permits pursuant to BAAQMD Regulation 2-6-409.10 which provides that a major facility review permit shall contain the following information and provisions:

“409.10A schedule of compliance containing the following elements:

- 10.1 A statement that the facility shall continue to comply with all applicable requirements with which it is currently in compliance;
- 10.2 A statement that the facility shall meet all applicable requirements on a timely basis as requirements become effective during the permit term; and

- 10.3 If the facility is out of compliance with an applicable requirement at the time of issuance, revision, or reopening, the schedule of compliance shall contain a plan by which the facility will achieve compliance. The plan shall contain deadlines for each item in the plan. The schedule of compliance shall also contain a requirement for submission of progress reports by the facility at least every six months. The progress reports shall contain the dates by which each item in the plan was achieved and an explanation of why any dates in the schedule of compliance were not or will not be met, and any preventive or corrective measures adopted.”

Since the District has not determined that the facility is out of compliance with an applicable requirement, the schedule of compliance for this permit contains only sections 2-6-409.10.1 and 2-6-409.10.2.

The BAAQMD Compliance and Enforcement Division has conducted a review of compliance over the past year and there is no evidence of on-going non-compliance and recurring pattern of violations that would warrant consideration of a Title V permit compliance schedule. The compliance report is contained in Appendix A of this permit evaluation and statement of basis.

## VI. Permit Conditions

The Major Facility Review permit contains conditions that are derived from previously issued District Authorities to Construct (A/C) or Permits to Operate (P/O). Permit conditions may also be imposed or revised as part of the annual review of the facility by the District pursuant to California Health and Safety Code (H&SC) § 42301(e), through a variance pursuant to H&SC § 42350 et seq., an order of abatement pursuant to H&SC § 42450 et seq., or as an administrative revision initiated by District staff. After issuance of the Title V permit, permit conditions will be revised using the procedures in Regulation 2, Rule 6, Major Facility Review.

When necessary to meet Title V requirements, additional monitoring, recordkeeping, or reporting has been added to the permit.

Each permit condition is identified with a unique numerical identifier, up to five digits.

All changes to existing permit conditions that are proposed in this action are clearly shown in “strike-out/underline” format in the proposed permit. When the permit is issued, all ‘strike-out’ language will be deleted and all “underline” language will be retained, subject to consideration of comments received.

### Changes to permit:

- Condition # 4995, #4996 and # 24621 were modified per NSR Application # 23594 to add the operation of the synthetic gypsum feeders

### **Condition # 4995**

**For S-222 Gypsum Feeder (6-WF-4), S-240 Additive Conveyor/Bins (6-BC-20, 6-SS-4, 6-SS-5, 6-SS-7, 6-SS-9), S-243 Gypsum Feeder (6-WF-9), S-244 Pozzolan Feeder (6-WF-7), S-245 Clay Feeder (6-WF-5) and S-246 Synthetic Gypsum Feeder (6-WF-11).  
Application # 4770, amended by A/N 23594.**

1. The owner/operator shall ensure visible particulate emissions from each source (S-222, S-240, S-243, S-244, S-~~245~~ and S-~~246~~) do not exceed Ringelmann 1.0 for more than 3 minutes in any hour or result in fallout on adjacent property in such quantities as to cause a public nuisance per Regulation 1-301. (Basis:~~BACT~~, Regulation 6-1-301, Regulation 1-301)



2. The owner/operator shall ensure all of the particulate emissions emitted from the handling of cement for the sources identified in Part #1 flow under negative pressure to a Baghouse, (A-222 (6-DC-4), A-240 (6-DC-21), A-243 (6-DC-9), A-244 (6-DC-7), A-245 (6-DC-5), respectively). The owner/operator shall equip each Baghouse with a District approved manometer for measuring the pressure drop across the Baghouse. (Basis: Regulation 2-2-212 Cumulative Increase)
3. The owner/operator shall ensure the outlet grain loading for each Baghouse does not exceed 0.0013 grain/dscf. (Basis: Regulation 2-2-301.1 BACT)
4. Deleted (startup condition)
5. Deleted (startup condition)
6. The owner/operator shall maintain daily records, in a District approved log, for the total hours of operation. The owner/operator shall maintain a quarterly record, in a District approved log, of the pressure drop. This log shall be retained for a period of at least five years from date of first entry. This log shall be kept on site and made available to the District's staff upon request. (Basis: Cumulative Increase)
7. The owner/operator shall ensure the total throughput of combined natural and synthetic gypsum at S-222, S-223, S-243 and S-246 does not exceed 84,210 tons in any consecutive 12-month period. (Basis: Regulation 2-2-212 Cumulative Increase)
8. The owner/operator shall ensure the total throughput of synthetic gypsum at S-222, S-223, S-243 and S-246 does not exceed 15,000 tons in any consecutive 12-month period. (Basis: Regulation 2-2-212 Cumulative Increase)

**COND# 4996**

**For S-216 Clinker Cake Conveyor (6-BC-13), S-217 Clinker Cake Conveyor (6-BC-15), S-221 Clinker Cake Feeder (6-WF-2), S-223 Synthetic Gypsum Feeder (6-WF-12), S-231 Pressed Cake Bin, S-242 Clinker Cake Feeder (6-WF-3). Application # 4770, amended by A/N 23594.**

1. The owner/operator shall ensure visible particulate emissions from each source (S-216, S-217, S-221, S-223, S-231, and S-242) do not exceed Ringelmann 1.0 for more than 3 minutes in any hour or result in fallout on adjacent property in such quantities as to cause a public nuisance per Regulation 1-301. (Basis: Regulation 6, Regulation 1-301)
2. All of the particulate emissions emitted from the handling of cement for the sources identified in Part #1 shall flow under negative pressure to a Baghouse, (A-216 (6-DC-13), A-217 (6-DC-15), A-221 (6-DC-6), A-231 (6-DC-3), A-242 (6-DC-11), respectively). Each Baghouse shall be equipped with a District approved manometer for measuring the pressure drop across the Baghouse. (Basis: Regulation 2-2-212 Cumulative Increase)
3. The owner/operator shall operate such that the outlet grain loading for each Baghouse A-217 and A-231 shall not exceed 0.006 grain/dscf. (Basis: Regulation 2-2-301.1 BACT)

4. The owner/operator shall operate such that the outlet grain loading for each Baghouse A-216, A-221, A-242 shall not exceed 0.0013 grain/dscf. (Basis: BACT, Cumulative Increase)
5. To demonstrate compliance with the emission limit in Part #4, the owner/operator shall perform a PM10 source test using CARB Method 501, USEPA Method 201/201A, or District approved equivalent at one of these abatement devices (A-216, A-221, or A-242), within 45 days of receiving the condition change for these sources. If the test result shows a failure to meet the limit in Part #4, then source tests shall also be performed on the other two abatement devices. The results shall be delivered to the District no later than 30 days from the date of the test. (basis: Regulation 2-1-403)
6. The owner/operator shall maintain daily records, in a District approved log, for the total hours of operation. The owner/operator shall maintain a quarterly record, in a District approved log, of the pressure drop. ~~The owner/operator shall maintain daily records of the hours of operation and of the pressure drop across each baghouse, in a District approved log.~~ This log shall be retained for a period of at least five years from the date of first entry. This log shall be kept on site and made available to the District's staff upon request. (Basis: Cumulative Increase)

**Condition # 24621**

Facility Wide, Lehigh Southwest Cement Company, Plant # 17

1. The owner/operator shall operate and maintain the Fugitive Dust Control Plan for sources that are not subject to NESHAP 40 CFR 63 Subpart LLL at the Cement and Rock Plants, including the onsite dust emissions from truck traffics. This plan must be updated periodically as necessary and must be submitted to the District for approval at least once every five year during the Title V permit renewal. This plan must be kept on site and made available to District's staff upon request. (Basis: Regulation 2-1-403)
2. The owner/operator shall perform source tests for the following abatement devices at least once every five years to demonstrate with compliance limits of Regulation 6-1. The owner/operator shall obtain approval for all source test procedures from the District's Source Test Section prior to conducting any tests. The owner/operator shall comply with all applicable testing requirements as specified in Volume V of the District's Manual of Procedures. The owner/operator shall notify the District's Source Test Section, in writing, of the source test protocols and projected test dates at least 7 days prior to testing. All measurements, records and data required to be maintained by the owner/operator shall be retained and made available for inspection by the District for at least five years (Basis: Regulation 2-1-403)

BAAQMD Source #	Abatement Description	Plant ID	Abating Source #	Source Description
A10	Dust Collector	6-DC-45-48	S-19	Clinker Storage Area
A-13	Dust Collector	6-DC-1	S-21	Roll Press Clinker Surge Bin and Feeder
A-58	Dust Collector	7-DC-8	S-74	Type II Mechanical Transfer System
A-111	Dust Collector	1-DC-1	S-111	Rail Unloading System Area 1

Permit Evaluation and Statement of Basis: Site A0017, Lehigh Southwest Cement Company  
24001 Stevens Creek Boulevard Cupertino, CA 95014

A-112	Dust Collector	1-DC-2	S-112	Additive Hopper Transfer System Area 1
A-113	Dust Collector	1-DC-3	S-113	Additive Bin Transfer Facilities Area 1
A-114	Dust Collector	1-DC-4	S-113	Additive Bin Transfer Facilities Area 1
A-115	Dust Collector	1-DC-5	S-115	Additive Storage Tripper
A-123	Dust Collector	2-DC-3	S-123	Rock Conveying System Area 2
A-131	Dust Collector	3-DC-1	S-131	Rock Sampling System Area 3
A-132	Dust Collector	3-DC-2	S-132	Preblend
A-133	Dust Collector	3-DC-3	S-132	Preblend
A-134	Dust Collector	3-DC-4	S-134	Preblend Storage Bin 4
A-135	Dust Collector	3-DC-5	S-135	High Grade Storage Bin
A-143	Dust Collector	4-DC-3	S-143	Raw Mill 1 Separator System 4
A-144	Dust Collector	4-DC-4	S-144	Raw Mill 2 Separator Circuit 4
A-151	Dust Collector	5-DC-1	S-151	Homogenizer 5
A-152	Dust Collector	5-DC-2	S-151	Homogenizer 5
A-153	Dust Collector	5-DC-3	S-153	Kiln Feed System
A-162	Dust Collector	5-DC-24	S-162	Clinker Silo A
A-163	Dust Collector	5-DC-25	S-163	Clinker Silo B
A-164	Dust Collector	5-DC-23	S-164	Free Lime Storage Bin
A-165	Dust Collector	5-DC-27	S-165	Clinker Transfer System
A-176	Dust Collector		S-167	Lime Bin
A-190	Dust Collector	5-DC-26	S-165	Clinker Transfer System
A-210	Dust Collector	6-DC-17	S-210	Finish Mill
A-211	Dust Collector	6-DC-12, 14,16 & 18	S-211	Separator
A-216	Dust Collector	6-DC-13	S-216	Cake Conveyor
A-217	Dust Collector	6-DC-14	S-217	Cake Conveyor
A-218	Dust Collector	6-DC-19	S-218 & S-412	Air Separator & Finish Mill
A-220	Dust Collector	6-DC-8	S-220	Mill and Peripherals
A-221	Dust Collector	6-DC-6	S-221 & S-223	Cake Feeder & Synthetic Gypsum Feeder
A-222	Dust Collector	6-DC-4	S-222	Gypsum Feed
A-230	Dust Collector	6-DC-2	S-230	Roller Press and Peripherals
A-231	Dust Collector	6-DC-3	S-231	Pressed Cake Bin
A-240	Dust Collector	6-DC-21	S-240	Additive Conveyor

Permit Evaluation and Statement of Basis: Site A0017, Lehigh Southwest Cement Company  
24001 Stevens Creek Boulevard Cupertino, CA 95014

				Bin
A-242	Dust Collector	6-DC-11	S-242	Cake Feeder
A-243	Dust Collector	6-DC-5	S-243 & S-246	Gypsum Feeder Reclaimed Cement & Synthetic Gypsum Feeder
A-244	Dust Collector	6-DC-7	S-244	Pozzolan Feeder
A-245	Dust Collector	6-DC-9	S-245	Clay Feeder, Gypsum
A-301	Dust Collector	7-DC-9	S-301	Rail Loadout System
A-340	Dust Collector	8-DC-50	S-340	Coarse Rock Withdrawal System
A-341	Dust Collector	8-DC-51	S-341	Pre-Crushing Screen Rock Plant 3
A-342	Dust Collector	8-DC-52	S-342	Coarse Rock Crushing System 2
A-384	Dust Collector	8-DC-31	S-384	Rock Plant 2 Screen
A-390	Dust Collector	8-DC-30	S-390	Conveyor Belt
A-413	Dust Collector	6-DC-25	S-414	Kiln Dust Fugitive Bin
A-415	Dust Collector	6-DC-13	S-415	Finish Mill Building Conveyor
A-420	Dust Collector	7-DC-16	S-48	Bulk Cement Loadout Tank #1 and #2
A-421	Dust Collector	7-DC-17	S-48	Bulk Cement Loadout Tank #1 and #2
A-422	Dust Collector	7-DC-18	S-48	Bulk Cement Loadout Tank #1 and #2
A-423	Dust Collector	7-DC-12	S-49	Bulk Cement Loadout Tank #28
A-424	Dust Collector	7-DC-14	S-49	Bulk Cement Loadout Tank #28
A-425	Dust Collector	7-DC-13	S-50	Bulk Cement Loadout Tank #29
A-426	Dust Collector	7-DC-15	S-50	Bulk Cement Loadout Tank #29
A-427	Dust Collector	7-DC-19	S-49 & S- 50	Bulk Cement Loadout Tank #28 & #29
A-428	Dust Collector	7-DC-11	S-48	Bulk Cement Loadout Tank #1 and #2
A-429	Dust Collector	7-DC-10	S-49 & S- 50	Bulk Cement Loadout Tank #28 & #29
A-430	Dust Collector	7-PDC-1	S-54	Cement Packer #1
A-431	Dust Collector	7-PDC-2	S-55	Cement Packer #2
A-433	Dust Collector	7-DC-5	S-45	West Silo Top Cement Distribution

				Tower
A-434	Dust Collector	7-DC-6	S-46	Middle West Silo Top Cement Distribution Tower
A-435	Dust Collector	7-DC-7	S-47	East Silo Top Cement Distribution Tower
A-436	Dust Collector	6-DC-49	S-17	Clinker Transfer Area
A-447	Dust Collector	6-DC-51	S-19	Clinker Storage Area
A-448	Dust Collector	6-DC-52	S-19	Clinker Storage Area
A-449	Dust Collector	6-DC-53	S-19	Clinker Storage Area
A-450	Dust Collector	6-DC-54	S-19	Clinker Storage Area

**VII. Applicable Limits and Compliance Monitoring Requirements**

This section was deleted and combined with Section IV.

The combined Section IV and VII of the permit is a summary of numerical limits and related monitoring requirements for each source. The summary includes a citation for each monitoring requirement, frequency of monitoring, and type of monitoring. The applicable requirements for monitoring are specified in Table IV & VII.

**VIII. Test Methods**

This section of the permit lists test methods that are associated with standards in District or other rules. It is included only for reference. In most cases, the test methods in the rules are source test methods that can be used to determine compliance but are not required on an ongoing basis. They are not “applicable requirements” as defined by Regulation 2-6-202.

If a rule or permit condition requires ongoing testing, the requirement will also appear in Section IV of the permit.

Changes to Permit

There are no changes to Section VIII in this action.

**VIII. Permit Shield:**

Changes to permit:

This action proposes no changes to permit shields.

**IX. Glossary**

Changes to permit:

- Added definition of Recordkeeping, R: The owner/operator shall keep the records onsite for at least five years and shall make the records available to District staff upon request.
- Added definition of CARB E.O. = California Air Resources Board Executive Order

**X. Revision History**

Changes to permit:

- Application 23663 (NSR # 23594), Minor Revision was added

## **XII. State Implementation Plan**

### Changes to permit:

This section has been deleted. The address for EPA's website is now found in Sections III and IV.

### **D. Alternate Operating Scenarios:**

No alternate operating scenario has been requested for this facility.

### **E. Compliance Status:**

The owner certified that all equipment identified in this revision will comply with applicable requirements on August 17, 2011. There is no evidence of on-going non-compliance and no recurring pattern of violations that would warrant consideration of a Title V compliance schedule.

### **F. Differences between the Application and the Proposed Permit:**

None.

**APPENDIX A**  
**BAAQMD COMPLIANCE REPORT**

**COMPLIANCE & ENFORCEMENT DIVISION**

**Inter-Office Memorandum**

**August 15, 2011**

TO: JOHN CHILADAKIS – DIRECTOR OF ENGINEERING

FROM: BRIAN BATEMAN – DIRECTOR OF ENFORCEMENT

SUBJECT: UPDATED REVIEW OF COMPLIANCE RECORD OF:

**LEHIGH SOUTHWEST CEMENT CO.- PERMANENTE PLANT, SITE #A0017**

**Background**

This review was initiated as part of the District evaluation of an application by Lehigh Southwest Cement Co. - Permanente Plant for a Title V Permit Renewal. It is standard practice of the Compliance and Enforcement Division to undertake a compliance review in advance of a renewal of a Title V Permit to Operate. The purpose of this review is to assure that any non-compliance problems identified during the prior 7-year permit term have been adequately addressed by returning the facility to compliance, or, if non-compliance persists, that a schedule of compliance is properly incorporated into the Title V permit compliance schedule. In addition, the review checks for patterns of recurring violation that may be addressed by additional permit terms. Finally, the review is intended to recommend, if necessary, any additional permit conditions and limitations to improve compliance.

**Compliance Review**

Staff reviewed Lehigh Southwest Cement Co. – Permanente Plant Annual Compliance Certifications for July 1, 2004 to August 11, 2011 and found no ongoing non-compliance and no recurring pattern of violations. Facts surrounding the most recent violations suggest that additional monitoring or permit conditions might improve compliance.

Staff conducted a compliance review of 27 Notices of Violation (NOVs) issued to Lehigh Southwest Cement Co. from July 1, 2004 through August 11, 2011. While the cement manufacturing facility received a number of violations over this 7-year period, for facilities as large, complex, and heavily regulated as a cement manufacturing facility within the Bay Area Air Quality Management District's jurisdiction, violations are likely to occur. It is important to note that all of the violations associated with the NOVs were in compliance at the time of this review; furthermore, the District's analysis of the NOVs for the 7-year period indicated that there is no ongoing violation or pattern of recurring violation that would require a compliance schedule.



REVIEW OF COMPLIANCE RECORD OF:  
**LEHIGH SOUTHWEST CEMENT CO. – PERMANENTE PLANT SITE #A0017**  
August 15, 2011  
Page 2 of 5

Understanding how the District handles the violations associated with the NOV's is important to understanding how the District evaluated the facility's compliance status. Whenever the District discovers a violation, it begins a two-step process. The first step is to end the violation and bring the alleged violator back into compliance. Once compliance is achieved, the second step is to proceed with penalty assessment. It is District policy to not proceed with penalty assessment until compliance has been achieved. If a facility has not achieved compliance in a timely fashion, the District proceeds with additional enforcement action. The vast majority of Notice of Violation penalties are resolved through settlement negotiations.

The results of the District's compliance review are shown in Table I. As stated above, the violations associated with the 27 NOV's were in compliance at the time of this review. In 93% of the violations, compliance was achieved prior to or within 1 day of issuance of the NOV. In the remaining 7% of the violations, the violations achieved compliance after issuance but did not represent ongoing violation that would require a compliance schedule in a Title V permit. There were multiple violations at two of the sources (S#165 & S#154) but causal analysis indicated different causes for the violations and there was no recurrent pattern, the prevention of which might be addressed by new monitoring or other permit conditions for these sources. Of the 27 NOV's issued, 11% of the violations resulted from the facility self-reporting, pursuant to Title V requirements. Several recent visible emissions violations might have been prevented had improved plans been in place to self-monitor compliance. Based on this review and analysis of all the violations for the 7-year period, the Compliance and Enforcement Division has concluded that no schedule of compliance is necessary for the Title V permit as the record showed that the violations returned to compliance, were intermittent or did not indicate on-going non-compliance, there was no pattern of recurring violation, and the facility was in compliance at the time of this review. However, future compliance could be improved and particulate matter emissions reduced by the addition of a facility-wide permit condition requiring a fugitive dust control plan for sources not already subject to the operation and maintenance plan required under NESHAPS for Portland Cement Facilities, and a permit condition to require periodic performance tests for sources abated by dust collectors not currently subject to these requirements.

The violation details associated with the 27 Notices of Violation (32 violations) are summarized here and detailed in Table 1.

#### Emissions Violations

- Six (6) visible emissions violations occurred on the Clinker Handling System (Source #165) for unrelated reasons such as polyester bag problems, damaged Kevlar skirting, a damaged access door gasket, and excessive dust accumulation around the source.

H:\Enforcement\Lehigh\Lehigh Permit Draft TV renewal memo A0017 15August

REVIEW OF COMPLIANCE RECORD OF:

**LEHIGH SOUTHWEST CEMENT CO. – PERMANENTE PLANT SITE #A0017**

August 15, 2011

Page 3 of 5

- One visible emissions violation occurred at the Clinker Handling System during an emergency diversion of clinker.
- One visible emissions violation occurred at the Kiln Mill dust collectors (A#141/A#142) from 2 broken bags.
- One visible emissions violation occurred at the Clinker Cooler (Source #161) during a startup after a power outage shutdown, which resulted in fine raw clinker material flushing from the precalcining tower through the kiln into the Clinker Cooler.
- One excess emission violation occurred at the kiln (Source #154) for NOx limits for a two-hour period.
- One permit condition throughput violation occurred at the Rock Plant for excessive combined throughput of aggregate at several sources.
- One visible emissions violation occurred at the Preblend Dome (Source #132) when wind blew fugitive emissions through door openings, while a front loader drove into and out of the dome.
- One visible emissions violation occurred at the roll press mill (Source #230) when fine clinker dust overloaded the dust collection system, resulting in clogged dust collector bags.
- Two visible emission violations occurred at the kiln baghouse when a detached plume formed above baghouse.
- One visible emissions violation occurred at the rock plant belt conveyor turning point when dry materials were being processed without water spray abatement to prevent excessive dust.
- One visible emissions violation occurred between the primary and secondary crushers when dry materials were dumped into the upstream rock hopper without water spray abatement to prevent excessive dust.
- One visible emissions violation occurred at clinker storage silo A (Source #162) when clinker dust partially clogged the dust collection system intake vent reducing the dust collector's ability to collect and abate fine clinker dust.
- One visible emissions violation occurred at the synthetic gypsum weigh feeder 6-WF-11 during a material transfer operation when the dust collection system was not turned on.

Administrative Violations

- One violation occurred for failure to maintain quarterly manometer readings on the Cement Packers (Source #54/55).
- One violation occurred for missing visible emission inspection forms.
- One violation occurred for missing visible emission, pressure drop and surface moisture condition records.
- One violation occurred for missing visible emission inspection forms, pressure drop records, and late Title V deviation reporting.

REVIEW OF COMPLIANCE RECORD OF:

**LEHIGH SOUTHWEST CEMENT CO. - PERMANENTE PLANT SITE #A0017**

August 15, 2011

Page 4 of 5

- Two violations occurred for late reporting of Reportable Compliance Activity (RCA)<sup>1</sup>: for a NOx excess and late reporting of an inoperative monitor.
- Two violations occurred for failure to submit Title V deviation reports as required in their Title V permit.

**Permit Violations**

- Two permit violations occurred for several stockpiles of material that did not have permits when moisture content was determined to be below 5%. The permit application was subsequently received and the permit issued.
- Four permit violations occurred for two synthetic gypsum weigh feeders (6-WF-11 & 6-WF-12) that did not have permits. The permit application was subsequently received and the permit issued.

Staff also reviewed additional District compliance records for Lehigh Southwest Cement Co. - Permanente Plant for July 1, 2008 through August 11, 2011. During this period Lehigh Southwest Cement Co. - Permanente Plant activities known to the District include:

The District received seventy (70) air pollution complaints alleging Lehigh Southwest Cement Co. - Permanente Plant as the source. Fourteen of these complaints were confirmed for visible emissions.

The District received nine (9) notifications for Reportable Compliance Activities (RCA): Five (5) inoperative NOx monitors, and four (4) requests for breakdown relief. None of the RCAs resulted in NOV's.

There are no enforcement agreements, open variances, or open abatement orders for Lehigh Southwest Cement Co. - Permanente Plant.

**Conclusion**

The Compliance and Enforcement Division has made a determination that for the 7-year period, July 1, 2004 to August 11, 2011, Lehigh Southwest Cement Co. - Permanente Plant was in intermittent compliance. There is no evidence of on-going non-compliance and no recurring pattern of violations that would warrant consideration of a Title V permit compliance schedule. To improve compliance and reduce dust emissions, the Division recommends additional facility-wide permit conditions for the Title V Permit under consideration; to require a fugitive dust control plan for sources not

Permit Evaluation and Statement of Basis: Site A0017, Lehigh Southwest Cement Company  
24001 Stevens Creek Boulevard Cupertino, CA 95014

REVIEW OF COMPLIANCE RECORD OF:

**LEHIGH SOUTHWEST CEMENT CO. – PERMANENTE PLANT SITE #A0017**

August 15, 2011

Page 5 of 5

subject to an operation and maintenance plan per NESHAP 40 CFR 63 Subpart LLL and to require periodic source tests for sources abated by dust collectors not currently subject to source test requirements. These additional permit conditions have been incorporated into the draft Title V permit.

JLK:JMM:KJW

Permit Evaluation and Statement of Basis: Site A0017, Lehigh Southwest Cement Company  
24001 Stevens Creek Boulevard Cupertino, CA 95014

BAAQMD Notices of Violation  
Lehigh Southwest Cement Co.-Permanente Plant (Site #A0017)  
July 1, 2004 - August 11, 2011  
TABLE 1

V#	S#	Occur	Issued	Reg	Violation Comments	Compliance Achieved	Basis for no compliance schedule
A48540	55	7/11/2002	9/25/2007	2-6-307	No quarterly manometer reading usage record.	9/25/2007	This administrative violation was for missing quarterly manometer readings for cement bag packing machines for 13 quarters. Compliance was achieved following staffing changes and the quarterly manometer recordkeeping resumed.
A11835	203	8/12/2004	7/21/2005	2-1-307	Condition ID #1720.3 - 4,200 Tons/Day	8/19/2004	This violation occurred when combined throughput at several sources at the Rock Plant exceeded the permit condition limit of 4,200 tons/day for 4 days. Compliance was achieved within 7 days and combined throughputs remain below the amount limited by the permit condition.
A48536	141	11/1/2005	1/25/2007	2-6-307	Missing visible emission records for 12 sources	10/30/2006	This administrative violation was for missing visible emission inspection forms for 12 sources over an 11-month period caused by staffing changes and turnovers. The violation was identified and self-reported by the facility. Compliance was achieved when the facility resumed maintaining daily visible emission inspection forms, instituted additional quality assurance and control procedures, and incorporated new procedures into personnel objectives.
A47925	N/A	5/9/2006	5/24/2006	6-301	Exceeded Ringelmann 1 visible emission	5/11/2006	This violation of excessive dust emissions occurred during an emergency diversion from the main clinker bucket conveyor. Compliance was achieved within two days by expediting repairs of the main clinker bucket conveyor so that emergency diversion was no longer necessary.
A48527	165	8/10/2006	8/22/2006	2-6-307	Visible Emission Ringelmann 1.5 thru 3 for 14.5 Minutes	8/11/2006	This violation of excessive dust emissions occurred due to an abatement device problem involving polyester bags in the baghouse. Compliance was achieved within 1 day when the polyester bags in the baghouse were replaced with Teflon bags and adjustments were made to airflow dampers.
A48528	165	8/21/2006	8/22/2006	2-6-307	Visible Emission Ringelmann 1.5 thru 3 for 15.25 Minutes	8/22/2006	This violation occurred at the Clinker Handling System bucket conveyor and was caused by fine clinker material sticking to the side of the buckets. Compliance was achieved within 1 day when the fine material deposited at the ground adjacent to the bucket turnaround point was cleaned up. The facility incorporated new inspection procedures into the Operation & Maintenance plan and enhanced housekeeping around the source. This violation was unrelated to a previous violation at this source.
A48529	165	9/18/2006	9/25/2006	2-6-307	Non-Compliance Major Facility Visible Emission Exceeding Ringelmann 1.5 thru 3 for 15 Minutes	9/25/2006	This violation occurred at the Clinker Handling System bucket conveyor and was caused by damaged Kevlar skirting on the outside of the bucket conveyor. It was corrected within 7 days when the damaged Kevlar skirting on the outside of the bucket conveyor was replaced. Skirting inspection was added to the inspection check list and enhanced inspection details were added to newly designed compliance software that has since been implemented at the facility.

Permit Evaluation and Statement of Basis: Site A0017, Lehigh Southwest Cement Company  
24001 Stevens Creek Boulevard Cupertino, CA 95014

BAAQMD Notices of Violation  
Lehigh Southwest Cement Co.-Permanente Plant (Site #A0017)  
TABLE 1  
July 1, 2004 - August 11, 2011

V#	S#	Occur	Issued	Reg	Violation Comments	Compliance Achieved	Basis for no compliance schedule
A48534	165	5/18/2006	12/1/2006	2-6-307	Covers 4 NOV issued Bet. 5/18/06 to 9/18/06	12/1/2006	This administrative violation was for failure to submit 10 and 30-day deviation reports as required in the Title V permit, resulting from the issuance of NOVs A47925, A48527-A48529. The violation was corrected on the date that the NOV was issued when the required reports were submitted.
A48543	350	1/6/2006	2/22/2008	2-6-307	Missing visible emission, pressure drop and surface wet condition monitoring records at 70 sources	2/22/2008	This administrative violation was for missing visible emission inspection forms, pressure drop readings and surface moisture condition monitoring for 70 sources over a 12-month period, caused by staffing changes and turnovers. The violation was identified and self-reported by the facility. Compliance was achieved when the facility resumed maintaining the visible emission inspection forms, pressure drop and surface moisture condition records and instituted additional quality assurance and control procedures.
A48541	165	8/20/2007	9/25/2007	2-6-307	Visible Emission > Ringelmann 1	8/25/2007	This violation of excessive dust emissions occurred at the Clinker Handling System when the access door gasket developed a gap. Compliance was achieved within 5 days when the gasket and casing at the access door were repaired.
A48550	154	11/1/2007	7/31/2008	2-6-307	Missing visible emission and pressure drop records at 20 sources & failure to notify deviation	8/8/2008	This administrative violation was for missing visible emission inspection forms and pressure drop readings for 20 sources over a 6-month period and late deviation reporting, caused by staffing changes and turnovers. The violation was identified and self-reported by the facility. Compliance was achieved when the facility resumed maintaining the visible emission inspection forms, pressure drop records and instituted additional quality assurance and control procedures.
A48545	154	1/30/2008	5/22/2008	2-6-307, 1-522.7	NOx excess of 821 ppm (limit=<615ppm) and late reporting of indicated excesses	5/22/2008	This violation occurred for 2 hours of excessive NOx emissions from the kiln, as recorded on the continuous emission monitor. Compliance was achieved when NOx emissions dropped below the level limited by the permit condition. The administrative violation was related to the late reporting of the NOx excess.
A50005	new 607	10/16/2008	11/20/2008	2-1-301, 2-1-302	Moisture content <5% therefore permit req'd	1/13/2009	This violation was for no Authority to Construct or Permit to Operate unpermitted stockpiles. Compliance was achieved when a permit application was received by the District and the Permit issued.
A50006	154	10/11/2008	2/4/2009	1-522.4	Failure to report equipment inoperation	10/20/2008	This administrative violation was for the late reporting of an inoperative NOx continuous emission monitor.
A50008	154	3/5/2009	4/7/2009	2-6-307	Exceed Ringelmann 1 visible emission	3/5/2009	This violation of excessive dust emissions occurred due to an abatement device problem involving 2 fiberglass bags in the baghouse. Compliance was achieved the same day when the bags were replaced with new ePTFE membrane bags. Prior to restarting the unit, all bags in that compartment were fully inspected and prioritized for June 2009 replacement.

Permit Evaluation and Statement of Basis: Site A0017, Lehigh Southwest Cement Company  
24001 Stevens Creek Boulevard Cupertino, CA 95014

BAAQMD Notices of Violation Lehigh Southwest Cement Co.-Permanente Plant (Site #A0017) July 1, 2004 - August 11, 2011  
TABLE 1

V#	S#	Occur	Issued	Reg	Violation Comments	Compliance Achieved	Basis for no compliance schedule
A50009	165	3/5/2009	4/7/2009	2-6-307	Exceeded Ringelmann 1 visible emission	3/5/2009	This violation of excessive dust emissions occurred for a short period at the clinker cooler bucket elevator discharge point the day that kiln operations resumed after a 2-1/2 month shutdown. Compliance was achieved during the investigation when the violation ended.
A50010	161	3/23/2009	4/7/2009	2-6-307	Exceeded Ringelmann 1 visible emission	3/23/2009	This violation of excessive dust emissions occurred when operations restarted following a power outage shutdown which resulted in fine, raw clinker material flushing from the precalciner tower through the kiln into the clinker cooler. Compliance was achieved when the fine materials were flushed through the process.
A50011	165	3/26/2009	4/7/2009	2-6-307	Exceeded Ringelmann 1 visible emission	3/27/2009	This violation of excessive dust emissions occurred when the wind entrained fine clinker dust that had accumulated around the conveyor system. Compliance was achieved when plant personnel removed the accumulated material, watered down the immediate area and instituted enhanced housekeeping procedures.
A50013	132	8/27/2009	9/8/2009	2-6-307	Exceeded Ringelmann 1 visible emission	8/27/2009	This violation of excessive dust emissions occurred when the wind blew fugitive emissions through door openings on the Preblend Dome while a front loader drove into and out of the dome. Compliance was achieved when the operation stopped.
A50014	230	11/16/2009	12/17/2009	2-6-307	Exceeded Ringelmann 1 visible emission	11/19/2009	This violation of excessive dust emissions occurred when fine clinker dust overloaded the dust collection system, resulting in clogged dust collector bags. Compliance was achieved when the roll press mill was immediately shut down and new bags were installed.
A50016	154	3/29/2010	4/26/2010	2-6-307	Exceeded Ringelmann 1 visible emission	4/26/2010	This violation of excessive visible emissions occurred when a detached plume formed above the kiln baghouse by a chemical process. Compliance was achieved the following day. A lime slurry injection system was permitted and installed and is expected to reduce compounds causing any detached plume formation.
A50019	383	5/25/2010	6/29/2010	2-6-307	Exceeded Ringelmann 1 visible emission	5/25/2010	This violation of excessive visible emissions occurred at the rock plant belt conveyor turning point when dry raw materials were not sufficiently moist to prevent excessive dust. Compliance was achieved when the water sprayer was turned on.
A50020	202	6/3/2010	6/29/2010	2-6-307	Exceeded Ringelmann 1 visible emission	6/3/2010	This violation of excessive visible emissions occurred between the primary and secondary crushers when dry raw materials were dumped into the upstream hopper without water spray abatement. Compliance was achieved when the water sprayer at the hopper was turned-on at the same day.
A51555	162	6/15/2011	7/22/2011	2-6-307	Exceeded Ringelmann 1 visible emission	6/15/2011	This violation of excessive visible emissions occurred at silo (A) due to an abatement device problem involving a partially clogged intake vent caused by material buildup. Compliance was achieved the same day when the excess emissions were ceased. The material buildup on the intake vent was removed.
A51556	223	6/27/2011	7/22/2011	2-6-307	Exceeded Ringelmann 1 visible emission	6/27/2011	This violation of excessive visible emissions occurred when the dust collection system for synthetic gypsum weigh feeder was not operating during material transfer operations. Compliance was achieved by shutting down the operation.

Permit Evaluation and Statement of Basis: Site A0017, Lehigh Southwest Cement Company  
 24001 Stevens Creek Boulevard Cupertino, CA 95014

BAAQMD Notices of Violation Lehigh Southwest Cement Co.-Permanente Plant (Site #A0017) July 1, 2004 - August 11, 2011  
 TABLE 1

V#	S#	Occur	Issued	Reg	Violation Comments	Compliance Achieved	Basis for no compliance schedule
A51557	223,246	6/27/2011	7/22/2011	2-1-301 & 2-1-302	No permit to operate on the two synthetic gypsum silos	7/22/2011	This violation was for no Authority to Construct or Permit to Operate for two (2) unpermitted synthetic gypsum weigh feeders. A permit application was subsequently received by the District and the Permit issued.
A51558	154	7/18/2011	7/22/2011	2-6-307	Exceeded Ringelmann 1 visible emission	7/18/2011	This violation of excessive visible emissions occurred when a detached plume formed above the kiln baghouse by a chemical process. Compliance was achieved within minutes by starting up a raw mill. A lime slurry injection system was permitted and installed and is expected to reduce compounds contributing to secondary plume formation.



**APPENDIX B**

**GLOSSARY**

**ACT**

Federal Clean Air Act

**APCO**

Air Pollution Control Officer

**ARB**

Air Resources Board

**BAAQMD**

Bay Area Air Quality Management District

**BACT**

Best Available Control Technology

**Basis**

The underlying authority which allows the District to impose requirements.

**CAA**

The federal Clean Air Act

**CAAQS**

California Ambient Air Quality Standards

**CAM**

Compliance Assurance Monitoring per 40 CFR, Part 64

**CAPCOA**

California Air Pollution Control Officers Association

**CEM**

Continuous Emission Monitor

**CEQA**

California Environmental Quality Act

**CFR**

The Code of Federal Regulations. 40 CFR contains the implementing regulations for federal environmental statutes such as the Clean Air Act. Parts 50-99 of 40 CFR contain the requirements for air pollution programs.

**CO**

Carbon Monoxide

**Cumulative Increase**

The sum of permitted emissions from each new or modified source since a specified date pursuant to BAAQMD Rule 2-1-403, Permit Conditions (as amended by the District Board on 7/17/91) and SIP Rule 2-1-403, Permit Conditions (as approved by EPA on 6/23/95). Cumulative increase is used to determine whether threshold-based requirements are triggered.

**District**

The Bay Area Air Quality Management District

**EPA**

The federal Environmental Protection Agency.

**Excluded**

Not subject to any District regulations.

**Federally Enforceable, FE**

All limitations and conditions which are enforceable by the Administrator of the EPA including those requirements developed pursuant to 40 CFR, Part 51, subpart I (NSR), Part 52.21 (PSD), Part 60 (NSPS), Part 61 (NESHAPs), Part 63 (MACT), and Part 72 (Permits Regulation, Acid Rain), including limitations and conditions contained in operating permits issued under an EPA-approved program that has been incorporated into the SIP.

**FP**

Filterable Particulate as measured by BAAQMD Method ST-15, Particulate.

**HAP**

Hazardous Air Pollutant. Any pollutant listed pursuant to Section 112(b) of the Act. Also refers to the program mandated by Title I, Section 112, of the Act and implemented by 40 CFR, Part 63.

**Major Facility**

A facility with potential emissions of: (1) at least 100 tons per year of regulated air pollutants, (2) at least 10 tons per year of any single hazardous air pollutant, and/or (3) at least 25 tons per year of any combination of hazardous air pollutants, or such lesser quantity of hazardous air pollutants as determined by the EPA administrator.

**MFR**

Major Facility Review. The District's term for the federal operating permit program mandated by Title V of the Federal Clean Air Act and implemented by District Regulation 2, Rule 6.

**MOP**

The District's Manual of Procedures.

**NAAQS**

National Ambient Air Quality Standards

**NESHAPS**

National Emission Standards for Hazardous Air Pollutants. See in 40 CFR, Parts 61 and 63.

**NMHC**

Non-methane Hydrocarbons (Same as NMOC)

**NMOC**

Non-methane Organic Compounds (Same as NMHC)

**NO<sub>x</sub>**

Oxides of nitrogen.

**NSPS**

Standards of Performance for New Stationary Sources. Federal standards for emissions from new stationary sources. Mandated by Title I, Section 111 of the Federal Clean Air Act, and implemented by 40 CFR, Part 60 and District Regulation 10.

**NSR**

New Source Review. A federal program for pre-construction review and permitting of new and modified sources of pollutants for which criteria have been established in accordance with Section 108 of the Federal Clean Air Act. Mandated by Title I of the Federal Clean Air Act and implemented by 40 CFR, Parts 51 and 52 and District Regulation 2, Rule 2. (Note: There are additional NSR requirements mandated by the California Clean Air Act.)

**Offset Requirement**

A New Source Review requirement to provide federally enforceable emission offsets for the emissions from a new or modified source. Applies to emissions of POC, NO<sub>x</sub>, PM<sub>10</sub>, and SO<sub>2</sub>.

**Phase II Acid Rain Facility**

A facility that generates electricity for sale through fossil-fuel combustion and is not exempted by 40 CFR, 72 from Titles IV and V of the Clean Air Act.

**POC**

Precursor Organic Compounds

**PM**

Particulate Matter

**PM<sub>10</sub>**

Particulate matter with aerodynamic equivalent diameter of less than or equal to 10 microns

**PSD**

Prevention of Significant Deterioration. A federal program for permitting new and modified sources of those air pollutants for which the District is classified "attainment" of the National Air Ambient Quality Standards. Mandated by Title I of the Act and implemented by both 40 CFR, Part 52 and District Regulation 2, Rule 2.

**PTE**

Potential to Emit as defined by BAAQMD Regulation 2-6-218

**SIP**

State Implementation Plan. State and District programs and regulations approved by EPA and developed in order to attain the National Air Ambient Quality Standards. Mandated by Title I of the Act.

**SO<sub>2</sub>**

Sulfur dioxide

**THC**

Total Hydrocarbons (NMHC + Methane)

**Title V**

Title V of the federal Clean Air Act. Requires a federally enforceable operating permit program for major and certain other facilities.

**TOC**

Total Organic Compounds (NMOC + Methane, Same as THC)

**TPH**

Total Petroleum Hydrocarbons

**TRMP**

Toxic Risk Management Plan

**TSP**

Total Suspended Particulate

**VOC**

Volatile Organic Compounds

**Units of Measure:**

bhp	=	brake-horsepower
btu	=	British Thermal Unit
cu. ft.	=	cubic foot
cfm	=	cubic feet per minute
dscf	=	dry standard cubic foot
dscfm	=	dry standard cubic foot per minute
g	=	gram
gal	=	gallon
gpm	=	gallons per minute
gr	=	grain
hp	=	horsepower
hr	=	hour
lb	=	pound
in	=	inch
max	=	maximum
m <sup>2</sup>	=	square meter
min	=	minute
mm	=	million
MMbtu	=	million btu
MMcf	=	million cubic feet
ppmv	=	parts per million, by volume
ppmw	=	parts per million, by weight
psia	=	pounds per square inch, absolute
psig	=	pounds per square inch, gauge
scfm	=	standard cubic feet per minute
tpy	=	tons per year
yr	=	year

**Appendix C**  
**NSR permit Evaluations**

**EVALUATION REPORT**  
**Lehigh Southwest Cement Company**  
Application #23594- Plant #17

**24001 Stevens Creek Blvd.**  
**Cupertino, CA 95014**

**I. BACKGROUND**

Lehigh Southwest Cement Company has applied for an Authority to Construct/Permit to Operate for the following equipment:

- S-223 Synthetic Gypsum Feeder, 6-WF-12 abated by existing A-221 Dust Collector (6-DC-6), DCE Vokes, 2,400 CFM**
- S-246 Synthetic Gypsum Feeder, 6-WF-11 abated by existing A-243 Dust Collector (6-DC-9), DCE Sintamatic, 1,550 CFM**

This application is the result of violation notice # A-51557 for no permit to operate and violation notice # A-51556 for visible emissions that Lehigh received on July 22, 2011. Source S-223 is controlled by the existing, permitted Dust Collector A-221, which is also abating the existing, permitted source S-221 Cake Feeder. Source S-246 is controlled by the existing, permitted Dust Collector A-243, which is also abating the existing, permitted source S-243 Gypsum Feeder. Both Synthetic Gypsum Feeders were installed on October 14, 1994, but was not placed in synthetic gypsum service until March of 2010 when the existing source S-414 was switched to store the Kiln Mill Dust Collector (KMDC) instead of synthetic gypsum under Application # 21217.

The maximum amount of synthetic gypsum usage through these two feeders is expected to be 15,000 tons/yr. This would be an equivalent of 750 delivery trucks per year, assuming each truck has 20 tons capacity. The synthetic gypsum feeders will not increase truck traffic because synthetic gypsum is used to replace the permitted natural gypsum. Based on the data forms from the permitted application for natural gypsum in 1990, the reported total natural gypsum throughput was 73,050 tons/yr. However, based on the required 5% composition of gypsum in the cement product, the total gypsum usage would be 84,210 tons/yr (1,600,000 ton clinker/yr / (1-0.95)). The District will modify existing Condition # 4995 to clarify the total throughput of natural and synthetic gypsum usage at Lehigh to be 84,210 tons/yr.

Abatement devices A-221 and A-243 are required to meet BACT of 0.0013 grain/dscf. For dust collectors, the particulate matter emissions are dependent on the hours of operation and outlet grain loading of the dust collector; therefore, the emissions from S-223 & A-221, and S-246 & A-243 were calculated and included in Application # 4770 when Sources S-221 and S-243 were permitted in 1990, and subsequently revised by Application # 17534 in 2008. As a result, there will be no emission increase because the synthetic gypsum feeders will have the same outlet grain loading requirement (0.0013 gr/dscf) and same air flow rate as in previous applications. This application will not result in any increase in cement production at the plant. Total annual production of clinker will still be limited to 1,600,000 tons. This application will not cause any increase in truck or rail traffic either to or from the Lehigh facility.

This application will not result in emission increases of PM10 from the dust entrainment from truck travel on dry paved roads within the plant from the levels already allowed.

Diagram of The Finish Mill (6-GM-2) for S-223

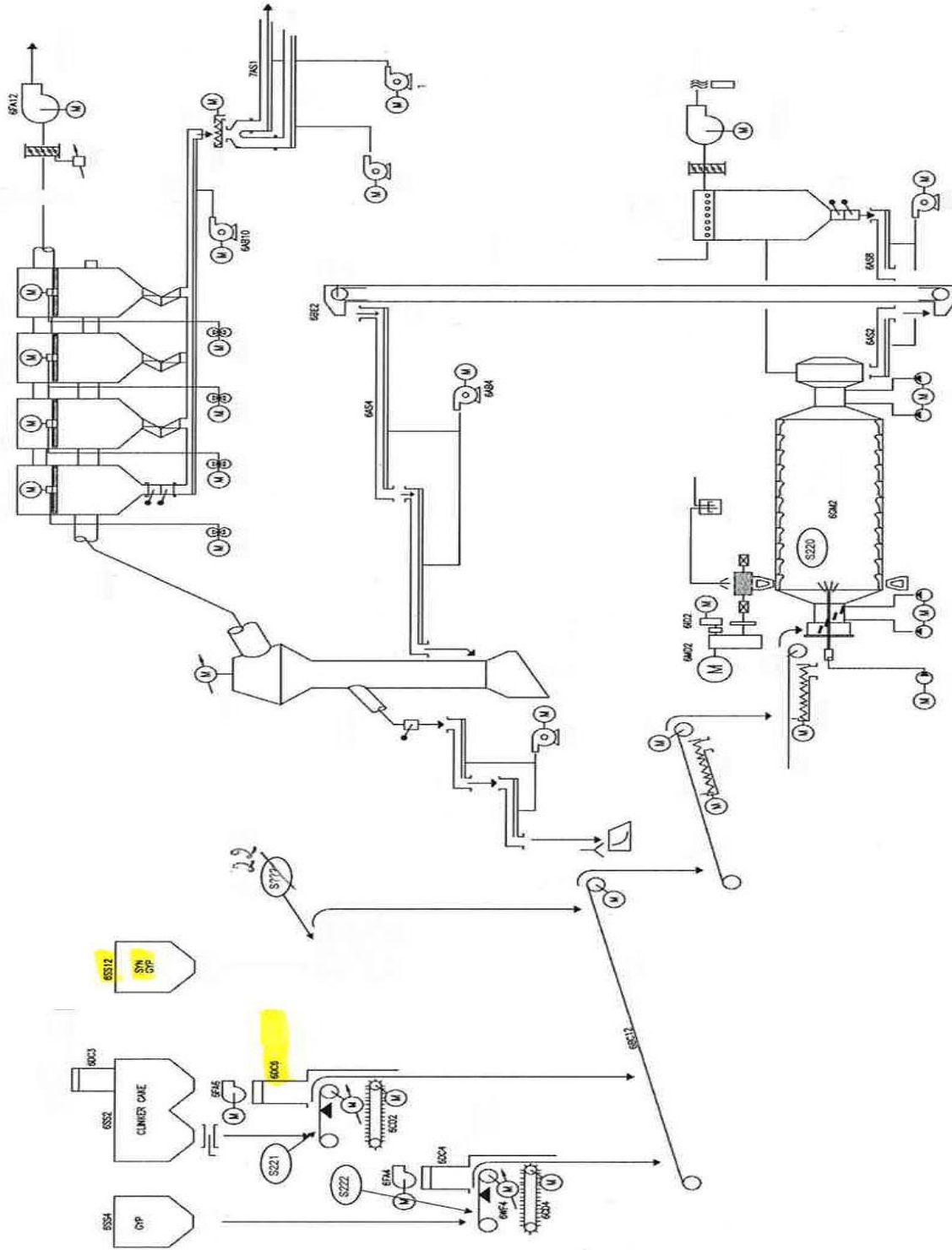



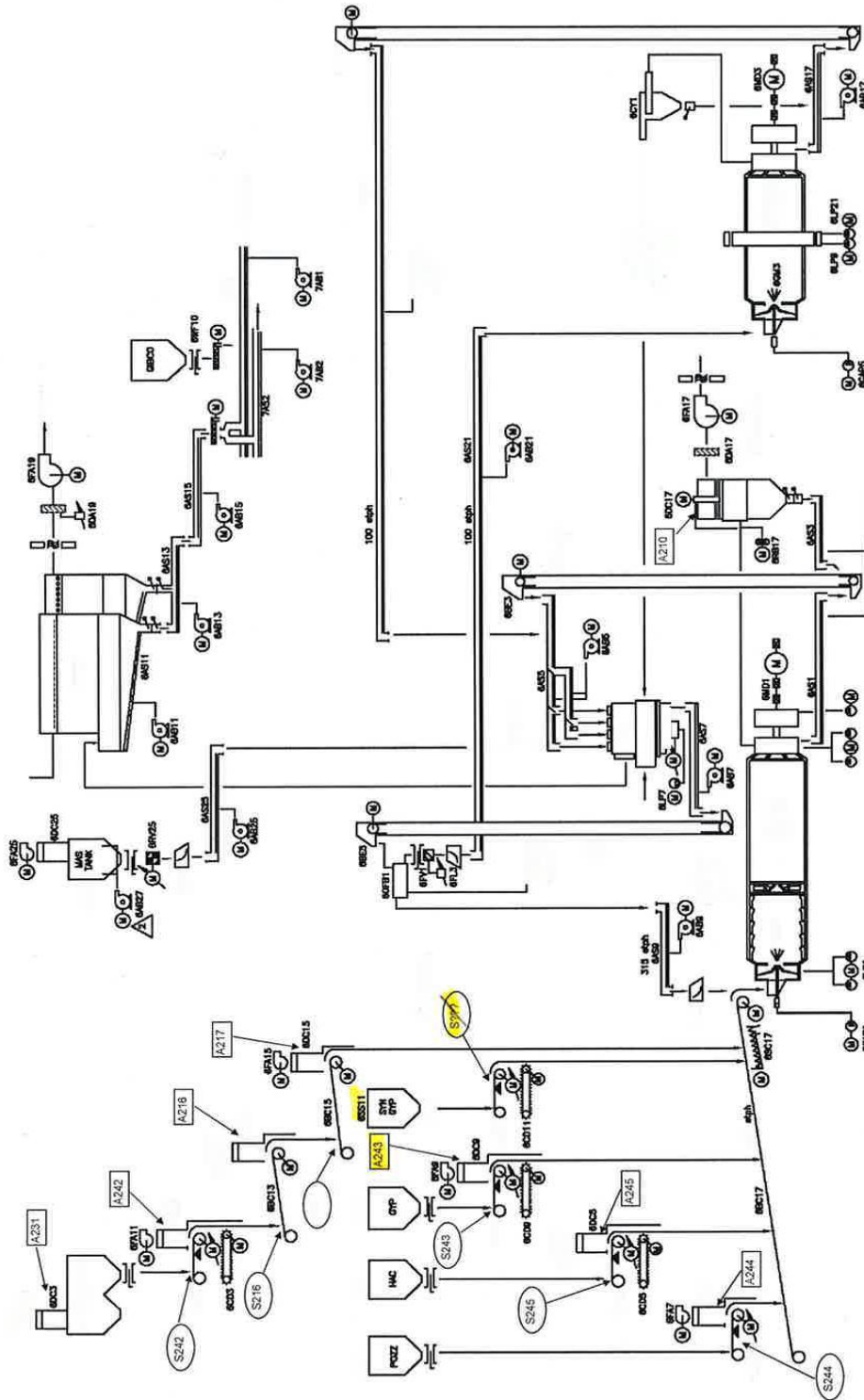

Diagram of The Finish Mill (6-GM-1) for S-246

Lehigh will submit a minor revision application to its Title V permit in the near future. The applicable requirements for these sources will be incorporated into the Title V permit as minor revisions.

## II. EMISSION CALCULATIONS

The emission from both synthetic feeders were included as part of Lehigh's cumulative increase in previous Application # 4770 because they share the permitted dust collectors (A-221 and A-243), which are currently abating sources S-221 and S-243. The emission calculation shown below is for information and toxic emission estimation only.

### **Synthetic Gypsum Feeder (S-223) and Dust Collector (A-221)**

The existing Dust Collector (A-221) was conditioned to meet BACT requirement of 0.0013 gr/dscf per Condition # 4996, Part 4 for a source that operates below 150°F.

#### S-223 & A-221 PM10 Annual Emissions:

Max. Annual PM10 emissions = 0.0013 gr/dscf x 1 lb/7000 grain x 2,400 ft<sup>3</sup>/min x 60 mins/hr x 24 hrs/day x 365 days/yr = 234 lbs/yr

#### S-223 & A-221 PM10 Daily Emissions:

Maximum Daily PM<sub>10</sub> emissions = 0.0013 gr/dscf x 1 lb/7000 grain x 2,400 ft<sup>3</sup>/min x 60 mins/hr x 24 hrs/day = 0.64 lbs/day

### **Synthetic Gypsum Feeder (S-246) and Dust Collector (A-243)**

The existing Dust Collector (A-243) was conditioned to meet BACT requirement of 0.0013 gr/dscf per Condition # 4995, Part 3.

#### S-246 & A-243 PM10 Annual Emissions:

Max. Annual PM10 emissions = 0.0013 gr/dscf x 1 lb/7000 grain x 1,550 ft<sup>3</sup>/min x 60 mins/hr x 24 hrs/day x 365 days/yr = 151.3 lbs/yr

#### S-246 & A-243 PM10 Daily Emissions:

Maximum Daily PM<sub>10</sub> emissions = 0.0013 gr/dscf x 1 lb/7000 grain x 1,550 ft<sup>3</sup>/min x 60 mins/hr x 24 hrs/day = 0.415 lbs/day

#### **Total emission from two feeders**

Annual PM<sub>10</sub> = 234 lb/yr + 151.3 lb/yr = 385 lb/yr or 0.193 ton/yr

## III. PLANT CUMULATIVE INCREASE SINCE 4/5/91

This application will not have any facility cumulative increase since there is no emission increase in PM10 emissions.

## IV. TOXIC SCREENING ANALYSIS

A risk screen is not required for this project because there is no increase in emissions of toxic substances from this application per Regulation 2-5.

Toxic emissions for nickel:

Nickel = 385 lb/yr x 0.006 x (15,000 tons synthetic gypsum/ 84,210 tons combined gypsum) = 0.41 lb/yr

<b>Gypsum</b>		<b>Emissions (based on 15,000 ton/yr synthetic gypsum)</b>	<b>Chronic Trigger Level (lb/yr)</b>	<b>Emission s</b>	<b>Acute Trigger Level (lb/hr)</b>
<i>Composition</i>	<i>% wt.</i>	<i>lb/yr</i>	<i>lb/yr</i>	<i>lbhr</i>	<i>lb/hr</i>
Calcium Sulfate	44-63	43.2	----	0.0049	----
Calcium Oxide	27-42	28.8	----	0.0033	----
Silica Dioxide	4.3-6.1	4.18	----	0.00048	----
Crystalline Silica <sup>1</sup>	0.1	0.069	120	0.00001	----
Aluminum Trioxide	1.4-3.7	2.54	----	0.00029	----
Nickel	0.2-0.6	0.41	0.43	0.000047	0.013
Vanadium	0.4-0.6	0.41	----	0.000047	0.066
Inert & metal Oxide	<1.0	0.69	----	0.000078	----

<sup>1</sup>Crystalline silica was not detected at a detection level of 0.2% wt. The District conservatively assumes the crystalline silica is ½ of the minimum detection, which is 0.1% wt.

**V. BEST AVAILABLE CONTROL TECHNOLOGY**

Sources S-223 and S-246 trigger BACT because the PM10 emissions are higher than 10 pounds per highest day per Regulation 2-2-301. Lehigh has already installed BACT(1) performance level Dust Collectors at sources S-223 and S-246 with an outlet grain loading limit of 0.0013 gr/dscf. Therefore, S-223 and S-246 comply with BACT requirement.

**VI. OFFSETS**

Offsets are not required since this application will not result in an emission increase in accordance with Regulation 2-2-303.

**VII. STATEMENT OF COMPLIANCE**

The owner/operator of sources S-223 & A-221 and S-246 & S-243 is expected to continue to comply with the requirements of District Regulation 1-301 “Public Nuisance” and District Regulation 6-1 “Particulate Matter and Visible Emissions”. The sources that are abated by the Dust Collectors are conditionally permitted to meet these requirements.

**PSD**

PSD does not apply because the installation of the two synthetic gypsum feeders will not result in emission increases and maximum air quality impacts are not major modifications per federal PSD

regulations, and do not exceed the significance levels for air quality impacts, as defined in federal PSD regulations.

#### **National Emissions Standards for Hazardous Air Pollutants Standards (NESHAPS)**

The owner/operator of sources S-223 and S-246 is expected to continue to comply with NSPS Subpart F, Portland Cement Plants and NESHAP Subpart LLL, National Emission Standards for Hazardous Air Pollutants from the Portland Cement Manufacturing Industry.

#### **California Environmental Quality Act (CEQA)**

This project is categorically exempt from CEQA because the permit application for a new or modified source or sources or for process changes which will satisfy the “No Net emission Increase” provisions of District Regulation 2, Rule 2, and for which there is no possibility that the project may have any significant environmental effect in connection with an environmental media or resources other than air quality per Regulation 2-1-312.11.

None of the toxic air contaminant triggers the toxic risk screening level; thus, this application does not require a toxic risk screening analysis per Regulation 2-5. The applicant has submitted a CEQA Environmental Information Form H for the project, and has not identified any potential significant impacts.

This project is over 1,000 ft from the nearest public school and is therefore not subject to the public notification requirements of Regulation 2-1-412.

#### **Major Facility Review (Title V)**

As discussed in the Section I, Background, the changes approved in this Authority to Construct will be a minor revision to the Major Facility Review permit.

S-223 and S-246, Synthetic Gypsum Feeders, are subject to SIP Regulation 6, Particulate Matter and Visible Emissions, which contains federally enforceable limits on particulate matter. Because the facility is subject to Major Facility Review in accordance with BAAQMD Regulation 2, Rule 6, monitoring for all federally enforceable requirements must be evaluated. As shown in Section II, Emission Calculations, the particulate emissions of sources S-223 and S-246 after abatement are estimated to be 234 lb/yr and 151.3 lb/yr, respectively. The sources will be monitored by checking the pressure drop across the dust collector and checking for visible emissions on a quarterly basis as required by Condition # 20751.

#### **Compliance Assurance Monitoring (CAM) Plan**

Sources S-223 and S-246 are exempt from the CAM plan because they have potential pre-control device emissions that are less than 100 tons per year of particulate matter per 64.2(1)(3). Sources S-223 and S-246 will be subject to the facility wide Condition # 24621 that requires source testing every five year.

### **VIII. CONDITIONS**

#### **Condition # 4995**

**For S-222 Gypsum Feeder (6-WF-4), S-240 Additive Conveyor/Bins (6-BC-20, 6-SS-4, 6-SS-5, 6-SS-7, 6-SS-9), S-243 Gypsum Feeder (6-WF-9), S-244 Pozzolan Feeder (6-WF-7), S-245 Clay Feeder (6-WF-5) and S-246 Synthetic Gypsum Feeder (6-WF-11).  
Application # 4770, amended by A/N 23594.**

1. The owner/operator shall ensure visible particulate emissions from each source (S-222, S-240, S-243, S-244, S-245 and S-246) do not exceed Ringelmann 1.0 for more

than 3 minutes in any hour or result in fallout on adjacent property in such quantities as to cause a public nuisance per Regulation 1-301. (Basis: ~~BACT~~, Regulation 6-1-301, Regulation 1-301)

2. The owner/operator shall ensure all of the particulate emissions emitted from the handling of cement for the sources identified in Part #1 flow under negative pressure to a Baghouse, (A-222 (6-DC-4), A-240 (6-DC-21), A-243 (6-DC-9), A-244 (6-DC-7), A-245 (6-DC-5), respectively). The owner/operator shall equip each Baghouse with a District approved manometer for measuring the pressure drop across the Baghouse. (Basis: Regulation 2-2-212 Cumulative Increase)
3. The owner/operator shall ensure the outlet grain loading for each Baghouse does not exceed 0.0013 grain/dscf. (Basis: Regulation 2-2-301.1 BACT)
4. Deleted (startup condition)
5. Deleted (startup condition)
6. The owner/operator shall maintain daily records, in a District approved log, for the total hours of operation. The owner/operator shall maintain a quarterly record, in a District approved log, of the pressure drop. This log shall be retained for a period of at least five years from date of first entry. This log shall be kept on site and made available to the District's staff upon request. (Basis: Cumulative Increase)
7. The owner/operator shall ensure the total throughput of combined natural and synthetic gypsum at S-222, S-223, S-243 and S-246 does not exceed 84,210 tons in any consecutive 12-month period. (Basis: Regulation 2-2-212 Cumulative Increase)
8. The owner/operator shall ensure the total throughput of synthetic gypsum at S-222, S-223, S-243 and S-246 does not exceed 15,000 tons in any consecutive 12-month period. (Basis: Regulation 2-2-212 Cumulative Increase)

**COND# 4996**

**For S-216 Clinker Cake Conveyor (6-BC-13), S-217 Clinker Cake Conveyor (6-BC-15), S-221 Clinker Cake Feeder (6-WF-2), S-223 Synthetic Gypsum Feeder (6-WF-12), S-231 Pressed Cake Bin, S-242 Clinker Cake Feeder (6-WF-3). Application # 4770, amended by A/N 23594.**

1. The owner/operator shall ensure visible particulate emissions from each source (S-216, S-217, S-221, S-223, S-231, and S-242) do not exceed Ringelmann 1.0 for more than 3 minutes in any hour or result in fallout on adjacent property in such quantities as to cause a public nuisance per Regulation 1-301. (Basis: Regulation 6, Regulation 1-301)
2. All of the particulate emissions emitted from the handling of cement for the sources identified in Part #1 shall flow under negative pressure to a Baghouse, (A-216 (6-DC-13), A-217 (6-DC-15), A-221 (6-DC-6), A-231 (6-DC-3), A-242 (6-DC-11), respectively). Each Baghouse shall be equipped with a District approved manometer for measuring the pressure drop across the Baghouse. (Basis: Regulation 2-2-212 Cumulative Increase)

3. The owner/operator shall operate such that the outlet grain loading for each Baghouse A-217 and A-231 shall not exceed 0.006 grain/dscf. (Basis: Regulation 2-2-301.1 BACT)
4. The owner/operator shall operate such that the outlet grain loading for each Baghouse A-216, A-221, A-242 shall not exceed 0.0013 grain/dscf. (Basis: BACT, Cumulative Increase)
5. To demonstrate compliance with the emission limit in Part #4, the owner/operator shall perform a PM10 source test using CARB Method 501, USEPA Method 201/201A, or District approved equivalent at one of these abatement devices (A-216, A-221, or A-242), within 45 days of receiving the condition change for these sources. If the test result shows a failure to meet the limit in Part #4, then source tests shall also be performed on the other two abatement devices. The results shall be delivered to the District no later than 30 days from the date of the test. (basis: Regulation 2-1-403)
6. The owner/operator shall maintain daily records, in a District approved log, for the total hours of operation. The owner/operator shall maintain a quarterly record, in a District approved log, of the pressure drop. ~~The owner/operator shall maintain daily records of the hours of operation and of the pressure drop across each baghouse, in a District approved log.~~ This log shall be retained for a period of at least five years from the date of first entry. This log shall be kept on site and made available to the District's staff upon request. (Basis: Cumulative Increase)

**Condition # 24621**

Facility Wide, Lehigh Southwest Cement Company, Plant # 17

1. The owner/operator shall operate and maintain the Fugitive Dust Control Plan for sources that are not subject to NESHAP 40 CFR 63 Subpart LLL at the Cement and Rock Plants, including the onsite dust emissions from truck traffics. This plan must be updated periodically as necessary and must be submitted to the District for approval at least once every five year during the Title V permit renewal. This plan must be kept on site and made available to District's staff upon request. (Basis: Regulation 2-1-403)
2. The owner/operator shall perform source tests for the following abatement devices at least once every five years to demonstrate with compliance limits of Regulation 6-1. The owner/operator shall obtain approval for all source test procedures from the District's Source Test Section prior to conducting any tests. The owner/operator shall comply with all applicable testing requirements as specified in Volume V of the District's Manual of Procedures. The owner/operator shall notify the District's Source Test Section, in writing, of the source test protocols and projected test dates at least 7 days prior to testing. All measurements, records and data required to be maintained by the owner/operator shall be retained and made available for inspection by the District for at least five years (Basis: Regulation 2-1-403)

BAAQMD Source #	Abatement Description	Plant ID	Abating Source #	Source Description
A10	Dust Collector	6-DC-45-48	S-19	Clinker Storage Area
A-13	Dust Collector	6-DC-1	S-21	Roll Press Clinker Surge Bin and Feeder
A-58	Dust Collector	7-DC-8	S-74	Type II Mechanical

				Transfer System
A-111	Dust Collector	1-DC-1	S-111	Rail Unloading System Area 1
A-112	Dust Collector	1-DC-2	S-112	Additive Hopper Transfer System Area 1
A-113	Dust Collector	1-DC-3	S-113	Additive Bin Transfer Facilities Area 1
A-114	Dust Collector	1-DC-4	S-113	Additive Bin Transfer Facilities Area 1
A-115	Dust Collector	1-DC-5	S-115	Additive Storage Tripper
A-123	Dust Collector	2-DC-3	S-123	Rock Conveying System Area 2
A-131	Dust Collector	3-DC-1	S-131	Rock Sampling System Area 3
A-132	Dust Collector	3-DC-2	S-132	Preblend
A-133	Dust Collector	3-DC-3	S-132	Preblend
A-134	Dust Collector	3-DC-4	S-134	Preblend Storage Bin 4
A-135	Dust Collector	3-DC-5	S-135	High Grade Storage Bin
A-143	Dust Collector	4-DC-3	S-143	Raw Mill 1 Separator System 4
A-144	Dust Collector	4-DC-4	S-144	Raw Mill 2 Separator Circuit 4
A-151	Dust Collector	5-DC-1	S-151	Homogenizer 5
A-152	Dust Collector	5-DC-2	S-151	Homogenizer 5
A-153	Dust Collector	5-DC-3	S-153	Kiln Feed System
A-162	Dust Collector	5-DC-24	S-162	Clinker Silo A
A-163	Dust Collector	5-DC-25	S-163	Clinker Silo B
A-164	Dust Collector	5-DC-23	S-164	Free Lime Storage Bin
A-165	Dust Collector	5-DC-27	S-165	Clinker Transfer System
A-176	Dust Collector		S-167	Lime Bin
A-190	Dust Collector	5-DC-26	S-165	Clinker Transfer System
A-210	Dust Collector	6-DC-17	S-210	Finish Mill
A-211	Dust Collector	6-DC-12, 14,16 & 18	S-211	Separator
A-216	Dust Collector	6-DC-13	S-216	Cake Conveyor
A-217	Dust Collector	6-DC-14	S-217	Cake Conveyor
A-218	Dust Collector	6-DC-19	S-218 & S-412	Air Separator & Finish Mill
A-220	Dust Collector	6-DC-8	S-220	Mill and Peripherals
A-221	Dust Collector	6-DC-6	S-221 & S-223	Cake Feeder & Synthetic Gypsum Feeder
A-222	Dust Collector	6-DC-4	S-222	Gypsum Feed
A-230	Dust Collector	6-DC-2	S-230	Roller Press and

				Peripherals
A-231	Dust Collector	6-DC-3	S-231	Pressed Cake Bin
A-240	Dust Collector	6-DC-21	S-240	Additive Conveyor Bin
A-242	Dust Collector	6-DC-11	S-242	Cake Feeder
A-243	Dust Collector	6-DC-5	S-243 & S-246	Gypsum Feeder Reclaimed Cement & Synthetic Gypsum Feeder
A-244	Dust Collector	6-DC-7	S-244	Pozzolan Feeder
A-245	Dust Collector	6-DC-9	S-245	Clay Feeder, Gypsum
A-301	Dust Collector	7-DC-9	S-301	Rail Loadout System
A-340	Dust Collector	8-DC-50	S-340	Coarse Rock Withdrawal System
A-341	Dust Collector	8-DC-51	S-341	Pre-Crushing Screen Rock Plant 3
A-342	Dust Collector	8-DC-52	S-342	Coarse Rock Crushing System 2
A-384	Dust Collector	8-DC-31	S-384	Rock Plant 2 Screen
A-390	Dust Collector	8-DC-30	S-390	Conveyor Belt
A-413	Dust Collector	6-DC-25	S-414	Kiln Dust Fugitive Bin
A-415	Dust Collector	6-DC-13	S-415	Finish Mill Building Conveyor
A-420	Dust Collector	7-DC-16	S-48	Bulk Cement Loadout Tank #1 and #2
A-421	Dust Collector	7-DC-17	S-48	Bulk Cement Loadout Tank #1 and #2
A-422	Dust Collector	7-DC-18	S-48	Bulk Cement Loadout Tank #1 and #2
A-423	Dust Collector	7-DC-12	S-49	Bulk Cement Loadout Tank #28
A-424	Dust Collector	7-DC-14	S-49	Bulk Cement Loadout Tank #28
A-425	Dust Collector	7-DC-13	S-50	Bulk Cement Loadout Tank #29
A-426	Dust Collector	7-DC-15	S-50	Bulk Cement Loadout Tank #29
A-427	Dust Collector	7-DC-19	S-49 & S-50	Bulk Cement Loadout Tank #28 & #29
A-428	Dust Collector	7-DC-11	S-48	Bulk Cement Loadout Tank #1 and #2
A-429	Dust Collector	7-DC-10	S-49 & S-50	Bulk Cement Loadout Tank #28 & #29
A-430	Dust Collector	7-PDC-1	S-54	Cement Packer #1



A-431	Dust Collector	7-PDC-2	S-55	Cement Packer #2
A-433	Dust Collector	7-DC-5	S-45	West Silo Top Cement Distribution Tower
A-434	Dust Collector	7-DC-6	S-46	Middle West Silo Top Cement Distribution Tower
A-435	Dust Collector	7-DC-7	S-47	East Silo Top Cement Distribution Tower
A-436	Dust Collector	6-DC-49	S-17	Clinker Transfer Area
A-447	Dust Collector	6-DC-51	S-19	Clinker Storage Area
A-448	Dust Collector	6-DC-52	S-19	Clinker Storage Area
A-449	Dust Collector	6-DC-53	S-19	Clinker Storage Area
A-450	Dust Collector	6-DC-54	S-19	Clinker Storage Area

## VII. RECOMMENDATION

Waive the Authority to Construct and issue a conditional Permit to Operate to Lehigh for the following equipment:

**S-223 Synthetic Gypsum Feeder, 6-WF-12 abated by existing A-221 Dust Collector (6-DC-6), DCE Vokes, 2,400 CFM**

**S-246 Synthetic Gypsum Feeder, 6-WF-11 abated by existing A-243 Dust Collector (6-DC-9), DCE Sintamatic, 1,550 CFM**

\_\_\_\_\_  
*Thu H. Bui*  
 Senior Air Quality Engineer  
 Engineering Division  
 date: \_\_\_\_\_

THB:E\Lehigh\HansonPermanente\23594e

## **Appendix D**

### **Compliance Assurance Monitoring (CAM) Analysis**

Permit Evaluation and Statement of Basis: Site A0017, Lehigh Southwest Cement Company  
24001 Stevens Creek Boulevard Cupertino, CA 95014

**Instructions:** This table was prepared in order to determine the applicability of CAM to each device listed in the Title V Permit. Note 40 CFR 64.2(a) is General Applicability which all three must be satisfied to apply; 40 CFR 64.2(b) is Exemptions.

**Notes:** Y: Yes, N: No, NE: Not Evaluated, M22: Epa Method 22, VE: Visible Emission observation, P:periodic, M:monthly, Q:Quarter, BLD:Bag Leak Detector

Source No (S-)	Source Description	Pollutant	Federally Enforceable Emissions Limit or Standard? 40 CFR 64.2(a)(1)		Uses a Control Device for Compliance? 40 CFR 64.2(a)(2)	Pre-Control PTE > Major Source Threshold (MST)? 40 CFR 64.2(a)(3)	Subject to CAM			Compliance Method in Title V Permit
			Emission Limit	Basis			Y/N	Reason	Description	
168	<u>Activated Carbon Storage Silo</u>	<u>Opacity</u>	< 10% opacity	60.672(b)	<u>A-168 Dust Collector</u>	N	N	<u>64.2(a)(3)</u>	<u>Pre-control PTE &lt; MST</u>	<u>Pressure Drop-P/M, Source Test - P/every 5 yrs- Condition # 24899 per 40 CFR 70.6(c)</u>
		<u>Particulate Matter</u>	<u>Ringelmann 1.0 Limitation</u>	SIP 6-301						
			<u>Visible Particles</u>	SIP 6-305						
			<u>Ringelmann 1.0 Limitation</u>	<u>BAAQMD Condition # 24899 Part 1</u>						
169	<u>Activated Carbon Feed Bin</u>	<u>Opacity</u>	< 10% opacity	60.672(b)	<u>A-169 Dust Collector</u>	N	N	<u>64.2(a)(3)</u>	<u>Pre-control PTE &lt; MST</u>	<u>Pressure Drop-P/M, Source Test - P/every 5 yrs- Condition # 24899 per 40 CFR 70.6(c)</u>
		<u>Particulate Matter</u>	<u>Ringelmann 1.0 Limitation</u>	SIP 6-301						
			<u>Visible Particles</u>	SIP 6-305						
			<u>Ringelmann 1.0 Limitation</u>	<u>BAAQMD Condition # 24899 Part 1</u>						

Attachment 2:

**Potential  
To Emit**

Permit Evaluation and Statement of Basis: Site A0017, Lehigh Southwest Cement Company  
24001 Stevens Creek Boulevard Cupertino, CA 95014

Source No (S- )	Source Description	Abatement Device	Material Stream	Applicable Annual Permit Limit	Process Fugitive Emissions (ton/yr)	Dust Collector Emissions (ton/yr)	Control Efficiency (%) <sup>1</sup>	Uncontrolled Emissions Based on Applicable Limit (ton/yr)
<u>223</u>	<u>Synthetic Gypsum Feeder</u>	<u>A-221 Dust Collector</u>	<u>Natural or Synthetic Gypsum</u>	<u>84,210 tons combined from S-222, S-223 S-243 and S-246</u>	<u>--</u>	<u>1.21E-1</u>	<u>99.5%</u>	<u>0.122</u>
<u>246</u>	<u>Synthetic Gypsum Feeder</u>	<u>A-243 Dust Collector</u>	<u>Natural or Synthetic Gypsum</u>	<u>84,210 tons combined from S-222, S-223 S-243 and S-246</u>	<u>--</u>	<u>7.56E-2</u>	<u>99.5%</u>	<u>0.076</u>

**Notes:**

1. Control efficiencies were applied consistent with EPA (AP-42) and BAAQMD (Statement of Basis) guidelines: 70% for water sprays, 95% for rock/ aggregate sources per AP-42 11.19, and 99.5% for cement/ clinker sources (NESHAP LLL Sources).